

MODERN WIRELESS



January

1/-

Vol. III. No. 8.

Edited by JOHN SCOTT-TAGGART, F.Inst.P., A.M.I.E.E.

January, 1925.

IN THIS ISSUE

A SEVEN VALVE T.A.T. RECEIVER

by JOHN SCOTT-TAGGART
F. INST. P., A. M. I. E. E.

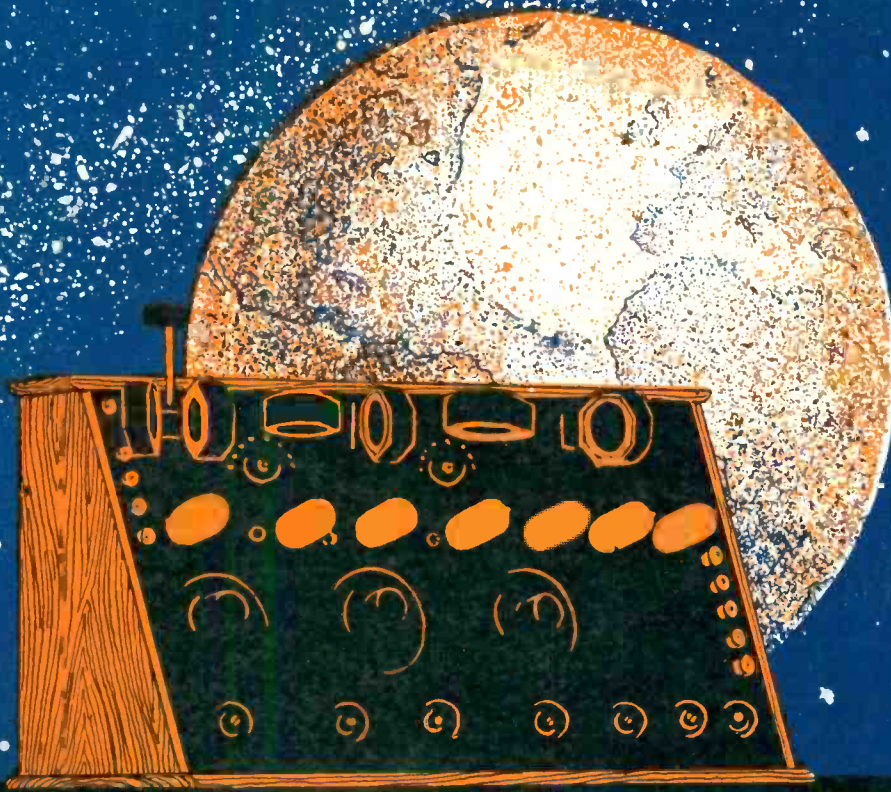

Vol. III.

No. 8

HOW TO MAKE:—

A 7-VALVE T.A.T. RECEIVER. *By John Scott-Taggart, F.Inst.P., A.M.I.E.E.*

A LONG RANGE 4-VALVE NEUTRODYNE SET. *By John Underdown.*

A 3-VALVE "NEUTRAL-GRID" RECEIVER. *By John W. Barber.*

AN IMPROVED 2-VALVE SET. *By Stanley G. Rattee, M.I.R.E.*

A SELECTIVE SINGLE VALVE SET. *By Herbert K. Simpson.*

TIMES OF AMERICAN TRANSMISSIONS.
WIRELESS ON THE ZR3,

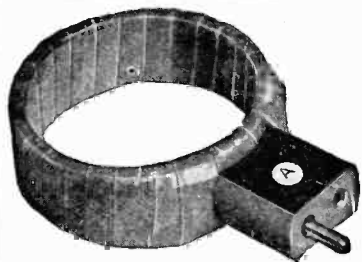

One of the Burndept Single-layer Coils for short-wave reception.

Build your set the Burndept way

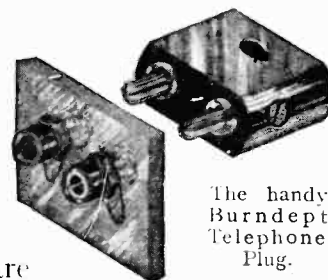

The handy Burndept Telephone Plug.

YOU know that Burndept Receivers are renowned for their efficiency and that many thousands of people are getting splendid results with these instruments. Do you know that you can obtain the same components from any Burndept Agent for your own apparatus? Build with Burndept Components to get the best results. Many of the sets described in *Modern Wireless*, *Wireless Constructor* and *Wireless Weekly* incorporate Burndept Components.

BURNDEPT Coils have extremely low self-capacity and high-frequency resistance and therefore their use is desirable in short-wave receivers. The whole range of Burndept Coils covers all wave-lengths from 80 to 25,000 metres. The spring sockets fittings are non-reversible. Full particulars of these Coils, together with prices and interesting laboratory data, are included in Publication No. 44, which will be sent free on request.

Set of 4 Extra Short-wave Coils (80-150 metres), 16s.
Set of 4 Concert Coils (150-800 metres), 16s.
Set of 9 Coils, S. 5 to 1,000 (750-20,000 metres), £3 16s. 6d.

MANY of the Burndept instruments are designed with the terminals at the back of the cabinet. The only connections on the panel are made by means of the neat Burndept Telephone Plugs, illustrated above. The telephone leads are connected to the non-reversible ebonite plugs by means of set screws. The sockets can be fitted easily to any panel.

No. 190.—Telephone Plug and Sockets, complete with drilling template and instructions, 3s. 9d.

THE Burndept Crystal Detector is of proven efficiency and heightens the good appearance of any receiver. It can be adjusted with ease and certainty and does not require frequent attention when set. The gold cat-whisker is advanced but not rotated by a micrometer screw adjustment, all movable parts and the sensitive synthetic crystal being enclosed in a glass tube.

No. 215.—Crystal Detector, with drilling template, screws and nuts, for panel mounting, 5s.

No. 216.—Crystal Detector, as illustrated, for experimental use, 12s. 6d.

Purchase Burndept by its name—substitutes are not the same.

One of the Burndept Multi-layer Coils.

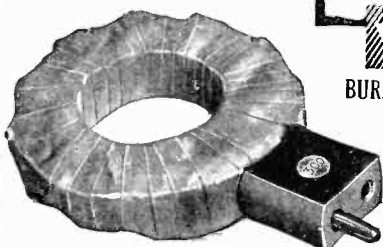

BURNDEPT

WIRELESS APPARATUS

BURNDEPT LTD., Aldine House, Bedford Street, Strand, W.C.2

Telephone: Gerrard 9072. Telegrams: Burndept, Westrand, London.

LEEDS: 12, Basinghall Street (near City Square). CARDIFF: 67, Queen Street. NORTHAMPTON: 10, The Drapery.

The experimental model of the Burndept Crystal Detector.

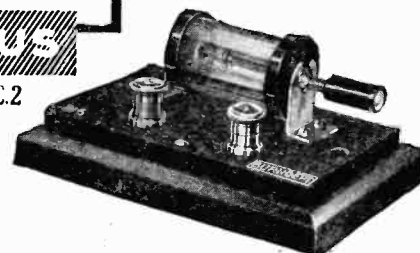



Editor:
 JOHN SCOTT-TAGGART,
 F.Inst.P.
Assistant Editor:
 PERCY W. HARRIS.
Staff Editors:
 E. H. CHAPMAN,
 M.A., D.Sc.
 A. D. COWPER, M.Sc.
 G. P. KENDALL, B.Sc.
 R. W. HALLOWS, M.A.
 S. G. RATTEE, M.I.R.E.

Contents

A Long-Range 4-Valve Neurodyne Receiver	... 891
By JOHN UNDERDOWN.	
In Passing	... 896
The Seven-Valve T.A.T. Receiver	... 898
By JOHN SCOTT-TAGGART, F.Inst.P., A.M.I.E.E.	
How the ZR-3 Was Piloted by Wireless	... 906
By CAPTAIN H. C. FLEMING.	
A Three-Valve "Neutral-Grid" Receiver	... 910
By JOHN W. BARBER.	
Regular Programmes from American Stations	... 923
By CAPTAIN L. F. PLUGGE, B.Sc., F.R.Ae.S., F.R.Met.S.	
Receiving Broadcast Music in the Congo Caves	... 928
By H. E. ALCOCK.	
Continental Methods of Calling	... 932
By CAPTAIN L. F. PLUGGE, B.Sc., F.R.Ae.S., F.R.Met.S.	
A Selective Single-Valve Receiver	... 936
By HERBERT K. SIMPSON.	
Your Earth Connection	... 944
By R. W. HALLOWS, M.A.	
An Improved Two-Valve Receiver	... 954
By STANLEY G. RATTEE, Member I.R.E.	
Some Three-Valve Reflex Circuits	... 969
By JOHN SCOTT-TAGGART, F.Inst.P., A.M.I.E.E.	
Regular Programmes from Continental Stations	... 975
By CAPTAIN L. F. PLUGGE, B.Sc., F.R.Ae.S., F.R.Met.S.	
Tested by Our- selves	... 984

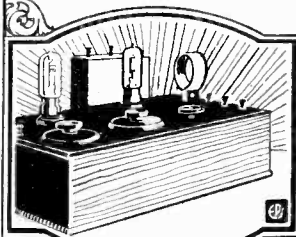

Scientific Adviser:
 Prof. G. W. O. HOWE,
 D.Sc., M.I.E.E.
Advisory Editors:
 Prof. R. WHIDDINGTON,
 M.A., D.Sc.
 Prof. C. L. FORTESQUE,
 M.A., M.I.E.E.
Advertisement Managers:
 BARCLAYS
 ADVERTISING LTD.,
 Bush House, Strand, W.C.2
 Tel.—City 9911.

RADIO PRESS, LTD.,
 Publishers of "Wireless Weekly" and "The
 Wireless Constructor,"
 Bush House, Strand, W.C.2.
 Telephone.—City 9911.

All correspondence relating to contributions is to be
 addressed to the Editor of "Modern Wireless."

Nothing contained herein is to be regarded as permission
 or encouragement to infringe any patent rights.

THEY GET THE BEST FROM YOUR VALVES

The H.T.C. Type of Valve Holders rid your receiver of short distance paralysis, distortion and flat tuning, which are caused by the inter-electrode and electrode lead capacity of the 4-pin Valve. Technical authorities are definite and consistent in their advice—use

LOW CAPACITY VALVE HOLDERS

especially for the H.F. Stages. Set builders should go one better and use them in every stage. There is no disputing the fact that the consistent use of the H.T.C. Type of Valve Holder by the Set Designers of the Radio Press is the surest indication of the efficiency involved in the principle.

Type A (above panel).

Type C (below panel).

WARNING.—Purchasers of Low Capacity Valve Holders are notified to beware of imitations. It is very necessary when buying to look for the name H.T.C. on the template without which no Valve Holder is genuine and original H.T.C. It may be taken that colourable imitations—simply because they are imitations—will not nor cannot give the efficiency which is inherent to the H.T.C.

BRITISH AND FOREIGN PATENTS APPLIED FOR.

The H.T.C. Low Capacity Valve Holder is an electrical and mechanical success. Contact is made by strong phosphor bronze springs. Soldering tags are provided. The electrical contacts are carried in a high grade moulding of very high insulation. Altogether a neatly and efficiently designed unit—worthy to carry the heart of your Set.

Type A (above panel) .. 1/9
 Type C (below panel) .. 1/6
 Templates supplied.

The Valve Holder carries the heart of your receiver. Ordinary valve sockets carried in a moulding of poor insulating properties with nuts and washers only 1/16th inch apart are proved, by simple comparison, of very low efficiency.

Dealers, if they do not stock H.T.C. Products, may try to persuade you that something they have in stock is just as good. If your dealer, perchance, does not stock them—be advised—send direct to:

H.T.C. ELECTRICAL CO., LTD.
 2 and 2a, BOUNDARIES ROAD, BALHAM, S.W.12.
 Trade Enquiries Invited. TELEPHONE: Battersea 374.

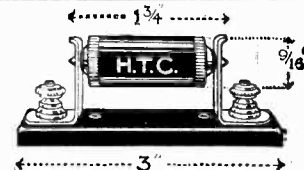

A FIXED DETECTOR. New and Reliable.
 A decade of crystal reception has seen the introduction of various types of crystal rectifiers—catwhisker and otherwise. After a few evenings' exasperating pastime searching for that sensitive spot—one you lost in the eternal search for one better—you'll find, as experimenters who have used crystal detectors for years, that a good crystal combination is alone satisfactory.
H.T.C. Detector 3/6
 Complete with Ebonite Base, Clips and Terminals .. 4/6

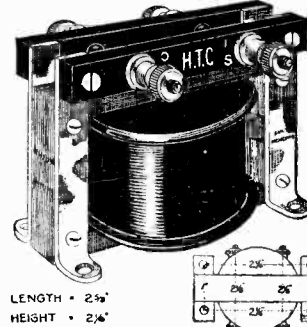

A DISTORTIONLESS L.F. TRANSFORMER. Specially wound to prevent breaking down of primary winding—a common fault with many expensive transformers. Price 15/—.

Barclays 402

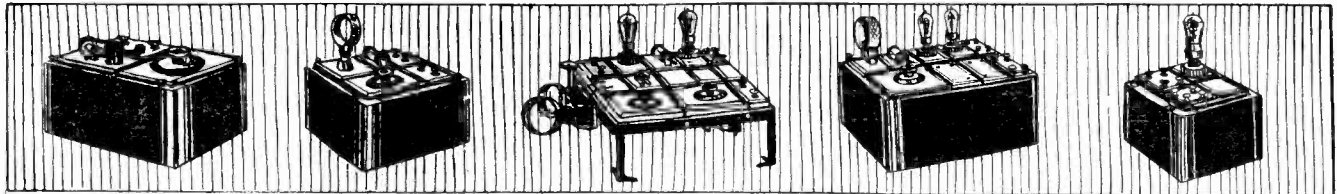

POLAR BLOK

SYSTEM OF WIRELESS SET CONSTRUCTION.

THE PROBLEM:

An experimenter wishes to be able to test out quickly and efficiently every new circuit for wireless reception without wasting his time and money in repeatedly drilling ebonite, soldering wires and building new wood cases for every set he constructs.

Is there a true unit system of set construction which does not employ "mystery boxes" and which enables an experimenter to test numerous circuits in such a way that he is always able to obtain good results, extend and alter at will, and give the set a superior appearance?

THE SOLUTION:

There is only one true unit system available—The Polar Blok System. Broadly speaking, it consists of three parts—

- An Extensible Frame**
- An Extensible Case**
- Unit Panels With Mounted Components**

The extensible frame is built by means of three types of tubes of different lengths, which are sprung on three types of connectors. No riveting is necessary, as the tubes are of light spring steel and the connectors are of aluminium.

The extensible case consists of a number of light metal panels which are fixed to the connectors. There are two sizes of ebonite unit panels. 5 in. by 4 in. or full size panel and 2½ in. by 4 in. or half panel. Each panel carries a component of some kind, such as a Polar Condenser, a valve holder and rheostat, a crystal holder, a series parallel switch, a variometer, a coilholder, etc., etc.

Each panel has a number of slotted head terminals which do not need soldering still enabling the experimenter to make quick and efficient connections. These panels can be placed in the frame in any desired order and secured to the frame rigidly by means of clamping units. The only tools required are a screwdriver and a pair of pliers. The price is remarkably low, so low that a first class four valve set can be built for about £11 11s.

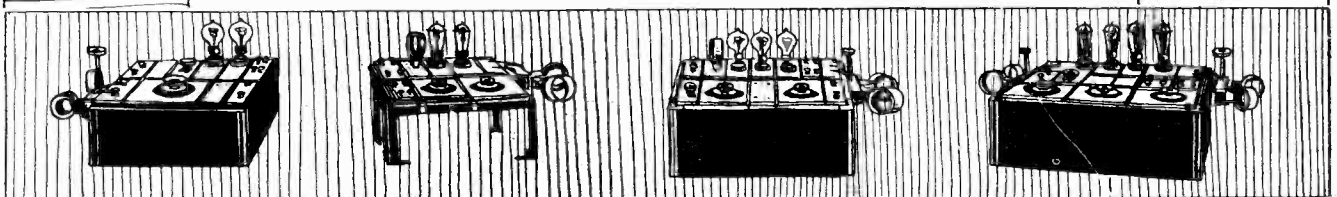
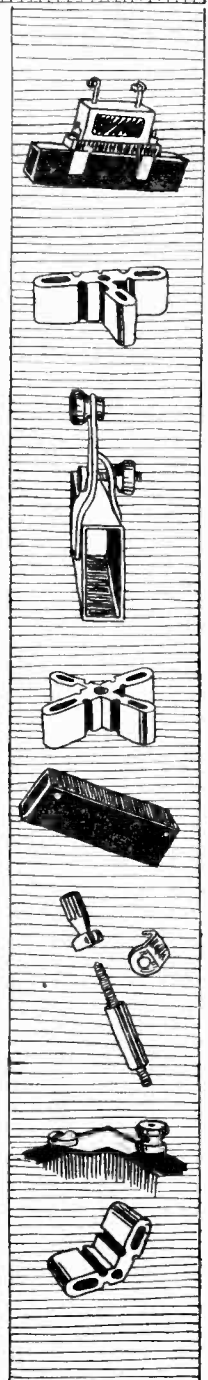
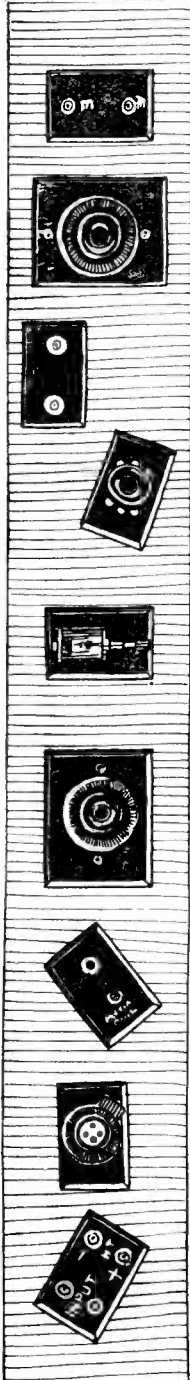

RADIO COMMUNICATION CO., LTD., 34-35, NORFOLK STREET, STRAND, W.C.2.

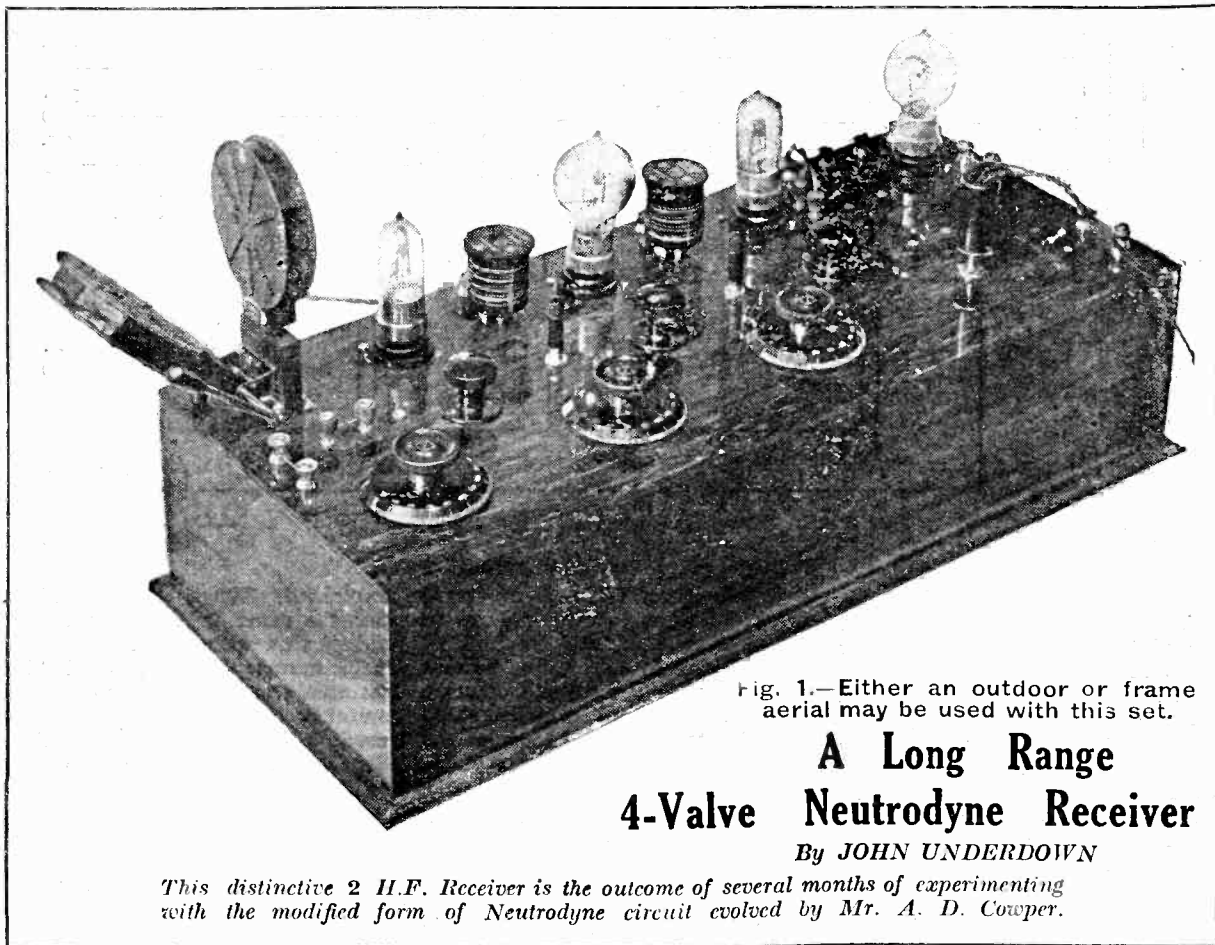

Fig. 1.—Either an outdoor or frame aerial may be used with this set.

A Long Range 4-Valve Neutrodyne Receiver

By JOHN UNDERDOWN

This distinctive 2 H.F. Receiver is the outcome of several months of experimenting with the modified form of Neutrodyne circuit evolved by Mr. A. D. Cowper.

RECENTLY I have been carrying out some experiments using a frame aerial and the 1 H.F. detector and 1 L.F. Neutrodyne receiver, described in *Wireless Weekly* of August 6th and 13th of 1924, and have had excellent and, in some cases, surprising results. At 12 miles S.E. of 21.O., that station gives sufficient loud speaker results for an average room, Madrid, several German stations and some of the distant B.B.C. stations being obtained at good phone strength. No reaction was used and a .00025 condenser across the frame was found to cover the whole 300 to 500 metre range comfortably. The set is quite stable and reaction control is easily obtained on the neutrodyne condenser.

General Considerations

Reviewing these results it was decided to apply the Cowper Neutrodyne circuit to two stages of high-frequency amplification, followed by a valve detector and one stage of power amplification, using a low-frequency transformer.

The set was to be as flexible as possible consistent with the use of no switches at all on the high-fre-

quency side, where their inclusion so often leads to instability. With the present receiver one, two or four valves may be used with very little trouble and the method of obtaining these will be dealt with fully later.

The tuning is designed to give a number of arrangements for working with both frame and outdoor aerials, also without using switches. Dual rheostats have been incorporated so that where current consumption is a serious consideration dull emitter valves may be used, and the last valve is arranged so that a higher low-tension voltage than on the first three may be applied to this valve, as, for example, when .06 valves are used for the first three stages and a 6 volt .25 ampere type for the power stage.

The Circuit

From the circuit diagram given it will be seen that a direct coupled circuit is used consisting of an inductance coil L_1 , tuned by a variable condenser C_1 of .0005 μ F. A loosely coupled circuit was not thought to be necessary here as the two stages of H.F. separately tuned render the set sufficiently selective

without the additional complication of a further control. L_2 , L_3 , and L_4 , L_5 are high-frequency transformers of which one winding in each case is utilised as a tuned anode coil (L_3 and L_5) and the other as the neutrodyne coil which effects a phase reversal essential to this method of stabilising tuned anode circuits.

The condensers C_2 and C_4 are the neutrodyne condensers whilst C_3 and C_5 of .0002 mfd. tune the anode circuits of the two H.F. valves.

Reaction Coil Connections

L_6 is a reaction coil variably coupled to the aerial coil by means of a two-coil holder. This may be inserted in the plate circuit of the detector valve V_3 by means of the two Clix sockets 6 and 7 in this latter circuit and the two sockets 1 and 2 connected to the moving coil block of the two-coil holder. These connections are effected externally by means of a length of twin flex seen in the photograph of the set with coils and valves inserted. Two Clix plugs on each end of the flex serve to make this connection and at the same time to get the direction of the reaction coil correct.

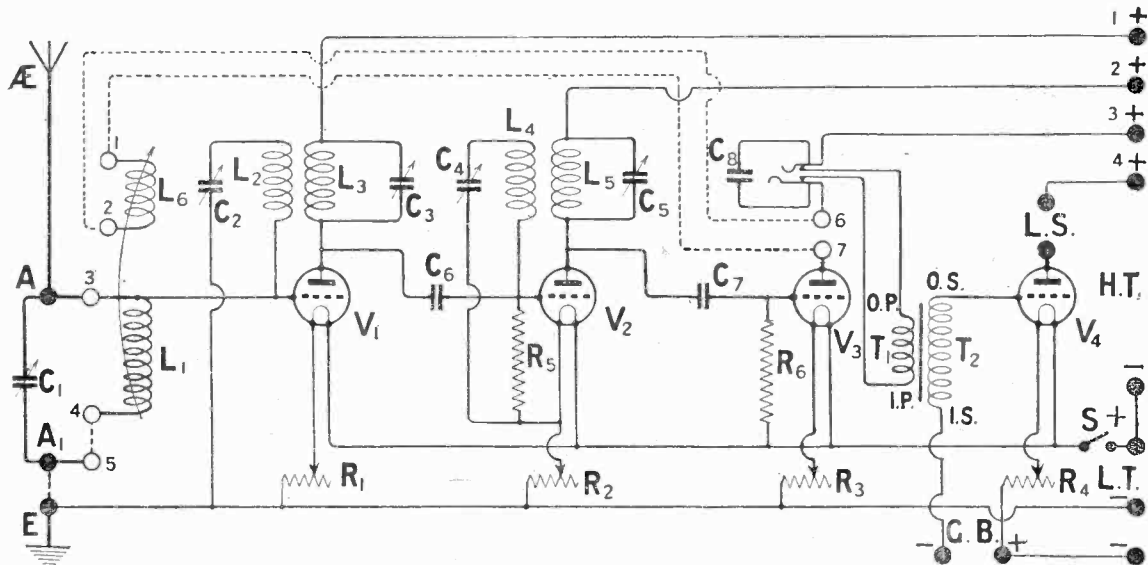

Fig. 2.—The theoretical circuit used.

The Use of a Jack

A double-circuit jack is used in the plate circuit of the detector valve so that telephones may be used here if desired with the last valve switched off on its filament rheostat R_4 . This jack, when the phones are not in use, brings the low-frequency transformer T_1 , T_2 into circuit. V_3 should then have its filament lit by switching on R_4 and the loud speaker should be connected to the terminals marked low speaker in the diagram.

The fixed condenser C_8 of .002 is used either across the phones or the primary winding T_1 of the L.F. transformer to act as a bypass condenser to give smooth reaction control. The grid condensers C_4 and C_7 are .0002 mfd., whilst the leaks R_5 and R_6 have values of 1.5 megohms. The more usual .0003 mfd. and 2 megohms may equally well be used here.

H.T. and L.T. Connections

It will be observed that the lead from the rheostat R_4 is not taken direct to low-tension minus as with the other three resistances but goes to a separate terminal. The purpose of this has been previously

explained. When it is desired to use the same L.T. voltage on all valves this is shorted to the other L.T. minus terminal. Grid bias terminals are included so that a suitable biasing battery may be used on the note magnifying valve. Separate terminals are also provided so that suitable plate voltages may be applied to each valve, allowing the best working conditions to be attained in each case. In the circuit diagram given terminals are shown throughout as full black circles, whilst Clix sockets are shown merely as plain circles with a distinguishing number.

Aerial Tuning Arrangements

There are four possible aerial tuning arrangements which are obtained as follows:—

The direct coupled system of tuning with parallel condenser,

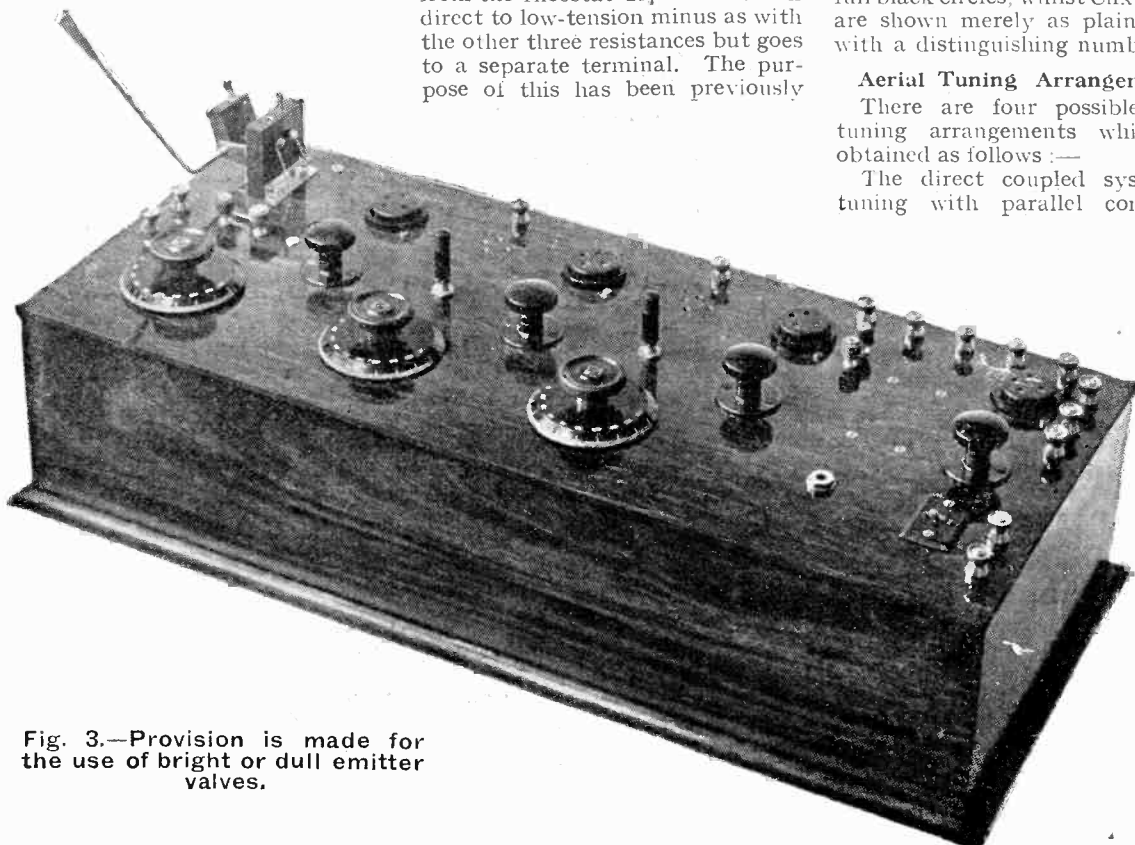

Fig. 3.—Provision is made for the use of bright or dull emitter valves.

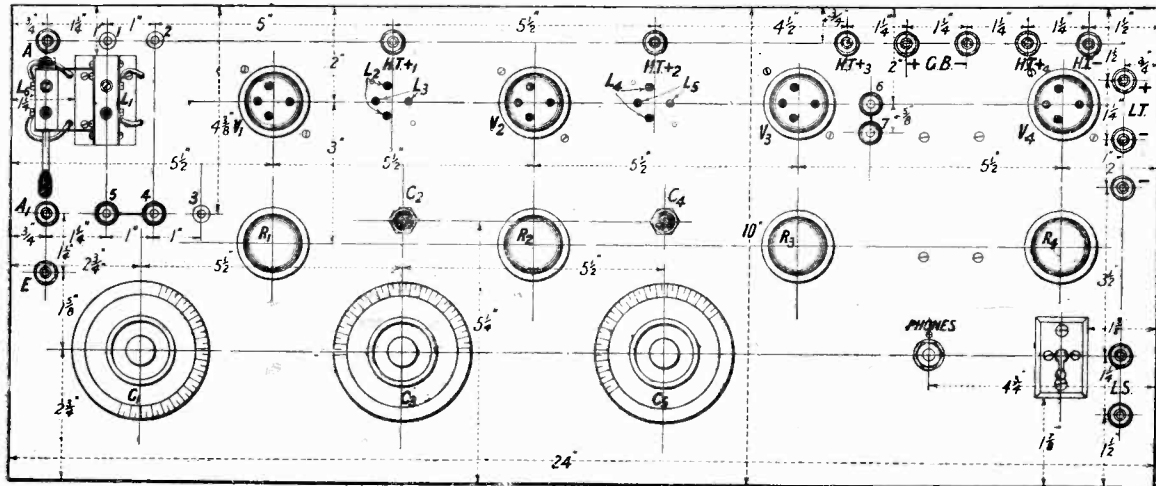

Fig. 4.—The front of panel drilling diagram should be consulted in setting out the panel. Blue Print No. 84A.

sued to the use of an ordinary outdoor or indoor aerial. In this case the aerial is taken to A, A₁ connected to E and to earth. Clix sockets 4 and 5 are connected together by two plugs joined by a short length of flex. If it is desired to use magnetic reaction, sockets 1 and 2 are joined to 6 and 7 as previously mentioned. This latter is necessary in all cases when reaction is obtained by coupling to the grid coil L₁.

Series tuning is obtained by connecting aerial to A₁, E to earth and also to socket 4.

Frame Connections

Frame aerial reception is effected by plugging the two ends of the frame into sockets 3 and 5, with A₁ connected to E. This arrangement is shown in Fig. 8, and has a number of advantages which will appeal to those who have no facilities for erecting the more usual outdoor aerial or who wish to take advantage of the directional properties of this type of aerial to get rid of interference. It also forms a serviceable arrangement where portability is desired, a collapsible frame in this case being ideal for the purpose. Reaction can easily be obtained by slightly upsetting the neutrodyne adjustments of either C₂, C₄ or both, as determined by experiment.

On the longer waves magnetic reaction may be found useful and this is obtained as in Fig. 9, the frame being plugged into sockets 4 and 5, A₁ joined to E. A small coil is then inserted in place of the usual aerial coil L₁, and reaction obtained on this from the plate circuit of the detector in the usual way.

General Layout

The photographs of the set clearly show how the components are disposed; the aerial condenser is seen on the left-hand side with the two anode tuning condensers to the right of this.

The two-coil holder is in the left-back corner, the fixed socket taking the grid coil and the moving that of the reaction. Connection to this latter is obtained by plugging into the Clix sockets immediately

to the rear and those shown near the third valve holder. Valves and H.F. transformers are disposed in one line to the rear of the panel and the resistances and neutrodyne condensers are arranged in the centre so that a symmetrical and pleasing appearance is obtained. H.T. and L.T. terminals are to the back and right-hand side of the panel, with the aerial-earth ones to the left, as are the sockets for the frame connections. These will be clearly

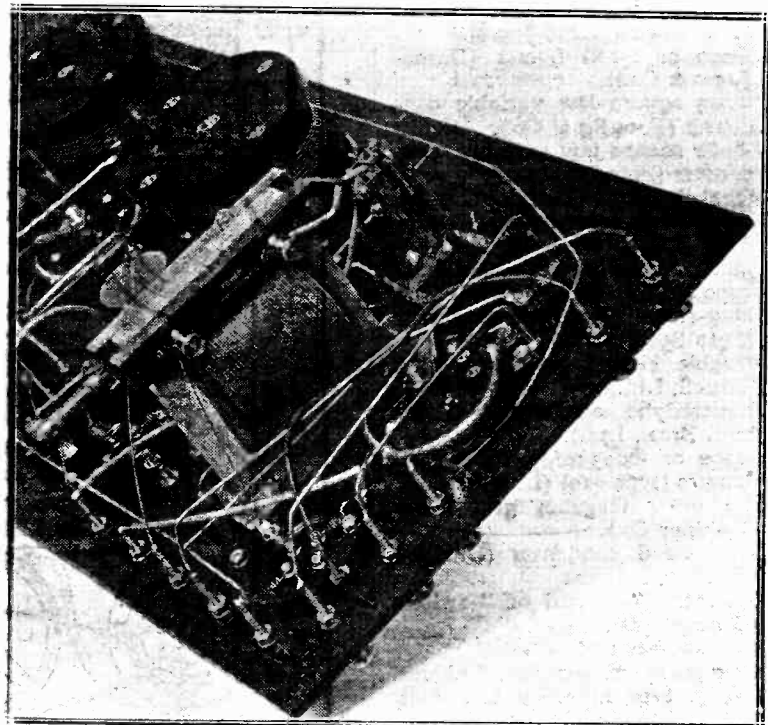

Fig. 5.—This photograph shows the last valve and jack connections.

seen in the front of panel diagram. The jack and a filament and H.T. "on and off" switch are seen to the right front.

Panel Arrangements

The under-panel arrangements are very compact, so that short leads are obtained. Type 610 Dubilier fixed condensers have been used with the new detachable clips allowing of very little room being taken for these. Since dull emitters can be used, dual rheostats can be used, incorporated. "Antiphonic" valve-holders have been used for the valves as the former are in some cases inclined to be microphonic. The photographs clearly show the disposition of the components so that nothing further need be written on this subject.

Components Required

In order that readers who wish to exactly duplicate the set may be saved trouble, the names of makers, as well as the components used, are given. From this it need not be implied that other good makes are not equally suitable, except in certain cases where space only allows those incorporated to be used.

The components are:—

- 1 Radion Mahogany Panel, 24 in. by 10 in. by $\frac{1}{4}$ in. (American Hard Rubber Co.).
 - 1 Oak or mahogany box, 24 in. by 10 in. by 5 in. deep and of $\frac{3}{8}$ in. thick wood (Burne-Jones).
 - 1 Magnum 2-coil holder (Burne-Jones & Co.).
 - 1 .0005 square law variable condenser (Peto Scott Co.).
 - 2 .0002 square law variable condensers (Peto Scott Co.).
 - 4 Dual rheostats (Burndept, Ltd.).
 - 4 Antiphonic valve-holders (Burndept, Ltd.).
 - 2 H.T.C. valve-holders under panel type (H.T.C. Co.).
 - 1 Max-amp power transformer (Peto Scott).
 - 1 Double circuit jack and plug (Elwell, Ltd.).
 - 2 Neutrodyne condensers (Gambrell Bros., Ltd.).
 - 2 .0002 or .0003 mfd. fixed condensers (type 610) (Dubilier Co.).
 - 2 1.5 or 2 megohm grid leaks (Dubilier Co.).
 - 1 .002 fixed condenser (Dubilier Co.).
 - 1 Filament "on and off" switch (Connecticut).
 - 7 Chx sockets and—
 - 6 Clix plugs (Autovevors, Ltd.).
 - 15 W.D. type nickelled terminals (Burne-Jones and Co.).
- Quantity of 16 and 20-gauge tinned copper wire and small lengths of twin and single flex.

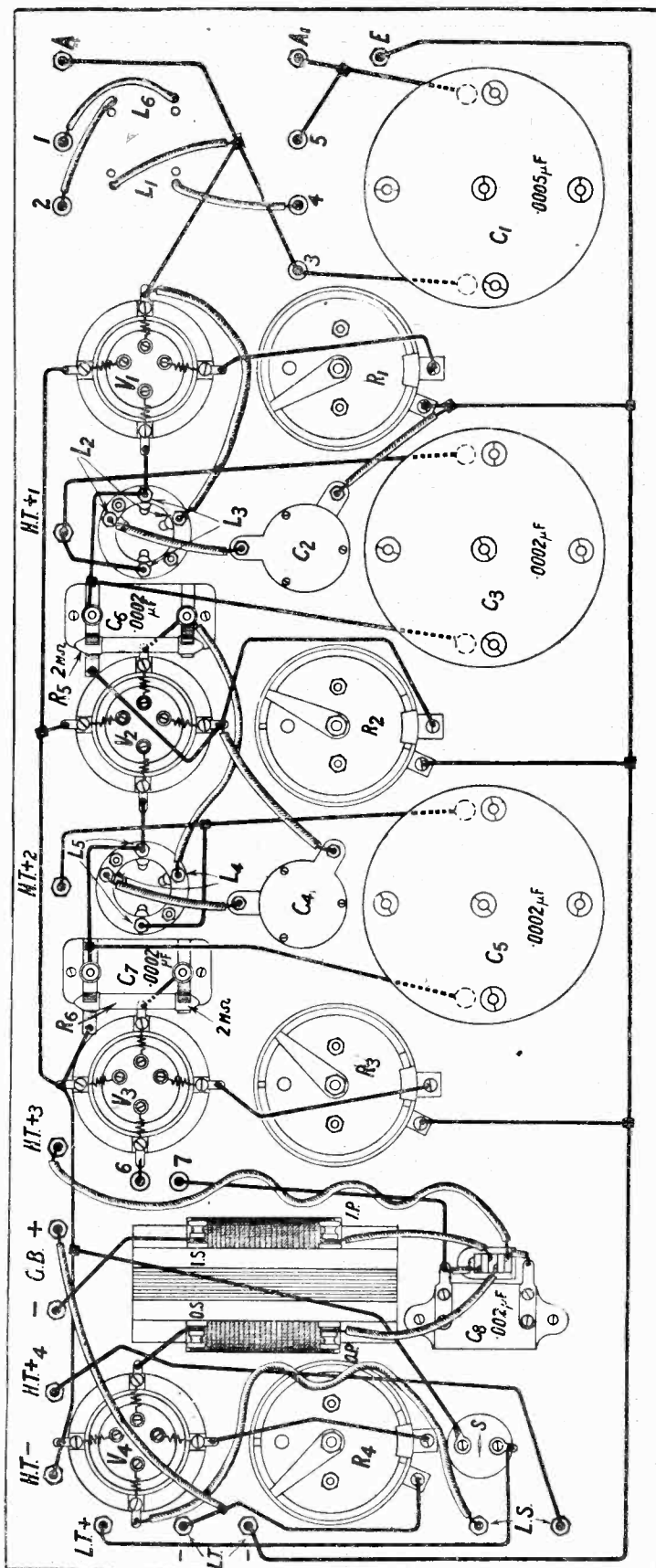

Fig. 6.—Wiring diagram. Blue Print No. 84B.

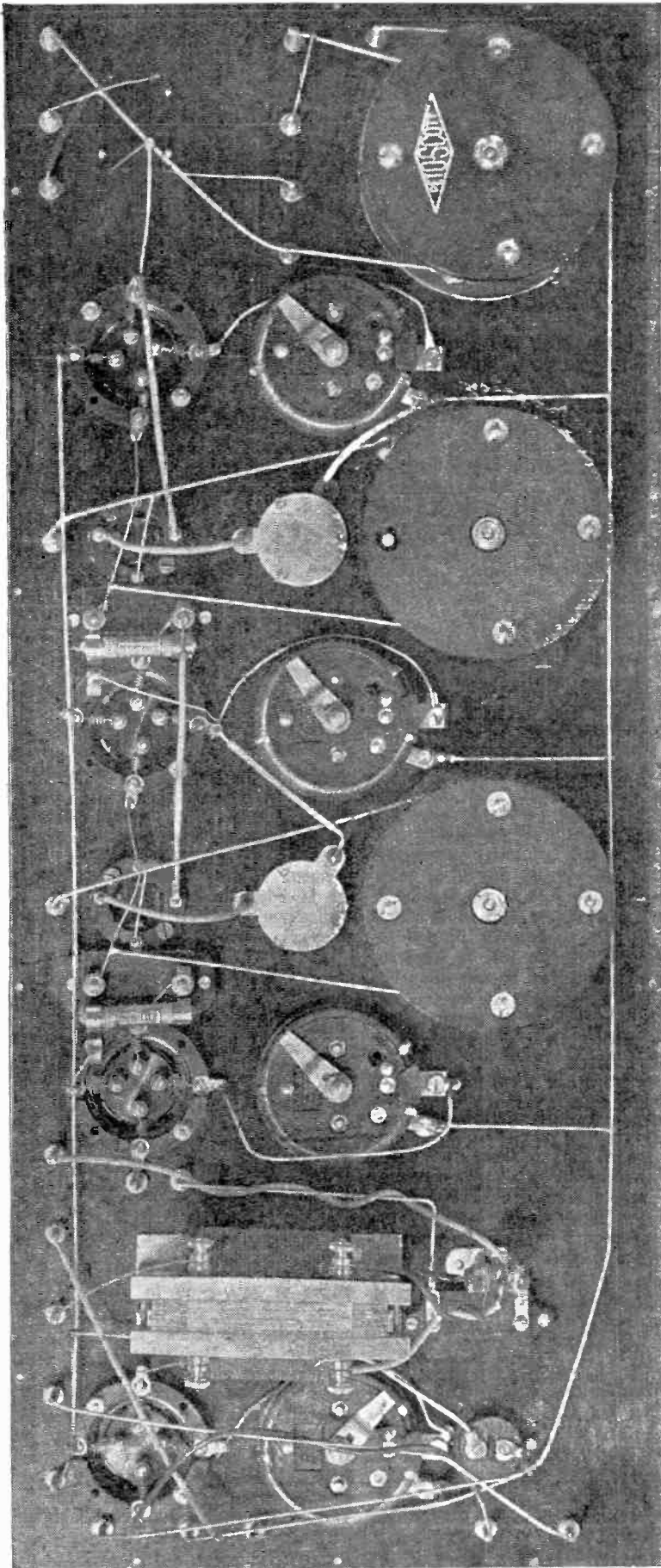

Fig. 7.—This photograph plan view clearly shows how the set is wired.

Construction

The use of guaranteed ebonite is strongly advised for the panel, in which case no matting to remove the surface skin is necessary and the panel may be at once marked out from the drilling diagram given. Little difficulty should be experienced in drilling the panel once it is set out. The only holes that present any difficulty are those for the "Antiphonic" valve-holders. These holes may be cut with an expanding type of bit in an ordinary carpenter's brace, or failing this, the valve-holders may be mounted on top of the panel.

The valve and transformer sockets and other of the lighter components should first be mounted and then the heavier variable condensers and transformer. The coil-holder need not be mounted until all the wiring below the panel is completed and then the latter can be placed in position on the case while the former is carried out. This is the most convenient method possible.

The Wiring

Tinned copper wire of 16 gauge has been used for the longer wires and 18 gauge for very short leads, which have to be bent at sharp angles.

The former wire should be thoroughly stretched until felt to give, when really straight lengths giving the set a professional appearance will be obtained. In my case I have carried out the neutrodyne circuits in the smaller wire covered with systollex sleeving so that they are easily distinguishable from the remainder of the circuits. Care should be taken to keep plate and grid wires well spaced and all leads as short as possible.

In some cases leads have been twisted together to minimise interaction and in these cases one wire is covered with sleeving. These will be seen in the photographs.

Testing the Set

Having completed the wiring place the set on test. First merely connect the L.T. battery, joining the two minus terminals together unless you are using a 4-volt accumulator on some valves and a 6-volt on the others. Place the filament switch S to the "on" position and plug a valve in turn into each valve-holder, seeing that it lights correctly as the rheostat is rotated.

A point to be noted here is that when a higher L.T. is applied to the last valve than to the others the last valve should be always switched off on its rheostat R₄ when the set is not in use. If this

(Continued on page 991.)



New Year Paving Stones

I SUPPOSE that I am pretty safe to say that you have been engaged recently in the manufacture of paving stones, or to put it more plainly, in making good resolutions. I only trust that you will be more successful in keeping them than I usually am. The only resolution that I have made myself this new year is that I will make no resolutions. Still there is no doubt that there are many wireless men who ought to do so at this time of year.

Resolutions

Some of you will promise yourselves, no doubt, no longer to have unsoldered joints beneath your panels; some, again, will forswear the use of solder. Speaking of solder reminds me that poor Professor Goop is terribly worried just now, for his wife has forbidden him absolutely to drop any more soldering paste on the drawing-room carpet. This, I should explain, is a new carpet, the old one having become so thoroughly impregnated with the sticky mess that all sorts of terrible things have been happening. Bingo, for instance, the Professor's little terrier, may be described as very much attached to it. In an unguarded moment the dog sat down upon it to warm himself before the fire. Later on, when Mrs. Goop called him to come for his evening meal, he looked at her pathetically and did not move. Thinking that he was sulky she admonished him and decided to carry him down to his kennel. When she tried to lift Bingo, she found that he was so firmly anchored that there was nothing for it but to cut out the portion of the carpet to which he was attached. This was five months ago, and Bingo is still wearing his quaint garment.

When the Professor Solders

What the Professor will do now that the new carpet has been put down I really cannot think. He is one of those thoroughly conscientious people who must solder

every joint, even if it is decently hidden away from view beneath the panel. My own motto is, "What the eye doesn't see the heart doesn't grieve for." I have the reputation for being one of the best solderers in Little Puddle-ton, acquired, I think, entirely from the fact that I have never allowed anyone to see the inside of my set. After all, who wants to be a plumber? But the Pro-



Bingo is still wearing his quaint garment.

fessor will not listen to my wise counsels. His brain, I know, is engaged in hatching out a new set, and when the soldering ceremony takes place almost anything may happen. He has what I should call a free action with the soldering-iron, for he frequently pauses in the middle of the job to explain some knotty point to anyone who is listening, or even to no one at all, in which case he gesticulates rather wildly and is apt to wave his iron about quite a lot. On one occasion he turned up two hours late at a meeting of the wireless club at which he was to give

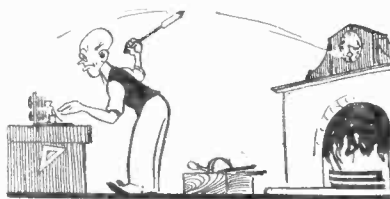

... fixed the hands firmly at half-past three.

an address, explaining that his clock had misled him. The glass covering its face he broke some time before with a blow from his soldering-iron, but on this occasion it appears that during one of his backward sweeps he had flung a blob of solder which fixed the hands

firmly at half-past three. With soldering paste he is simply awful.

Open-handedness

I do not believe in being stingy, but I think that you can overdo open-handedness with stuff of this kind. The Professor buys his a dozen tins at a time, running the contents of the lot into an old jam jar. When I tell you that he generally puts it on with a teaspoon, you will agree with me that he does not err by using too little. And the worst of it is that he carries the hot soldering-iron idea rather to extremes, chiefly through absent-mindedness. He believes in having several irons in the fire, but usually forgets all about them until they are white hot. Then he seizes one and brings it down squarely into the middle of the mess that he has made round his proposed joint. The result is that his room always smells as if somebody had been frying sausages in it, and the stuff simply flies all over the place.

The Puddleby Method

Mrs. Goop has approached Puddleby and myself with a view to our giving the Professor some instruction in the art of wielding the soldering-iron in the correct manner. Luckily the Professor is one of the kindest and the most polite of men, and he has so far taken our tuition in the best part. Puddleby's ideas and mine, unfortunately, do not quite coincide. He gives him an hour in the morning, whilst I take him in the evening. The result is that I spend most of my time in getting the Professor out of the bad habits which he has learnt from my co-instructor. Puddleby is far too much of a stylist. He believes that the whole art of soldering depends chiefly upon the stance. His method, I understand, is to make the pupil stand with his feet well separated and the weight evenly distributed between them. With the hot iron held in his right

hand he must keep his eye firmly on the joint, and swing his weapon slowly back without moving his head. During the back stroke solder is collected—or should be collected—from a conveniently placed stick. The weight is now chiefly upon the ball of the left foot whilst the right heel is slightly raised. During the forward stroke there must be an even gentle swing without any pressing, and a good follow-through must take place after solder has been applied to the joint. This is all very well in theory, but in the case of an impulsive person like Professor Goop, it does not work out at all in practice. He simply will not

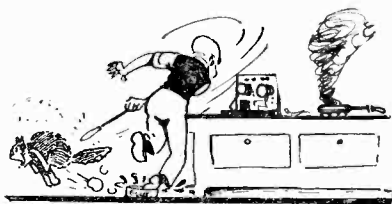

... landing it on the cat.

keep his eye on the joint, he will rise on his toes, and during the back swing he as often as not misses the solder altogether, landing his hot iron on the table-cloth, the cat, or anything that is within range. When coming forward again, he nearly always presses very badly. This usually means that he hits the table instead of the joint, and it is, of course, quite impossible to replace the divot which has been consumed by the heat of the soldering-iron.

My Own Idea

To this method my own ideas on the subject are diametrically opposite. I do not believe that stance matters a hang. I am sure that all these instructions of Poddleby's serve simply to cramp the Professor's style, and to make him more uncertain than ever. With a short-sighted pupil like the Professor, I feel that an entirely different method is required. For this reason, when I am instructing him, he goes to work quite differently. On his left hand he wears an asbestos glove. Having placed a blob of solder upon the bit of his soldering-iron, he makes a correct billiards bridge with the left hand, and, using the soldering-iron like a cue, would get there every time if only in his absent-mindedness he would not occasionally imagine that he was potting the red. When this happens he is apt to dig instead of making

a smooth, even stroke, so that as often as not the joint is destroyed even before it is made. Really, I am rather in despair over the Professor's progress, for after a month's hard work I do not think that he is much further on in the art of soldering than he was. If I were allowed to instruct him alone I am quite sure that he would shortly be making breaks of fifty before a joint was missed. And Poddleby, on the other hand, says that if he were himself in command, he could easily get the Professor's soldering handicap down to twenty-four. This I beg leave to doubt.

Something New

And now I am afraid that the Professor must work out his own salvation so far as solder and carpets are concerned, for I understand that as soon as he is left to himself he forgets all that I have taught him, and does not even adopt Poddleby's inferior idea. He just goes on the old slap-dash way, of which nothing, I am afraid, will cure him so long as he has two instructors. But what, after all, do a few carpets matter so long as he continues to turn out those amazing circuits which have for so long been the wonder and the despair of the world of wireless men? He is engaged at the moment upon what he calls his "Ether Super-purifier." I would like very much to give you the full details of this, but as his right-hand man in the experimental work, which has been occupying the whole of his time for the last six months, I am sworn to the most profound secrecy until the thing is perfected. In the strictest confidence, however, I may give you just a brief outline of what he is going to do.

The Ether Super-purifier

Why do people howl? Rather, perhaps, I should say why do people make their sets howl? Simply and solely because they pick up carrier waves and heterodyne them. Very well, then. It becomes at once quite obvious that if there were no carrier waves, even you, dear reader, could not send out far and wide those horrible noises which cause good men and true to lose their erstwhile sunny natures and to become potential, if not indeed, actual murderers. Working on these lines, the Professor and I have between us evolved a great scheme. When I say between us, I mean that I have been an extremely good listener whilst he talked, and that I have always been able to find the pliers when he wanted them. Any-

how, I have generously consented to his dividing with me the honour of the wonderful discovery which will shortly be given to an astonished world. To put it in a nutshell, our idea is an elaboration of the wave-trap. We make use of a carrier wave-trap, which successfully bottles up all carrier waves that may be knocking about. These are subjected to a straining process by means of an entirely new circuit, in which the Bothoff-Therunyum effect is utilised to the full. Before the year is out every city, town, village and hamlet of this country will have erected a communal Ether Super-purifier on the Goop principle. With its help the objectionable carriers will be removed, and even the most hardened sinners of the locality will find that, use their reaction coils as they may, they are quite unable to get so much as a squeak by them. We have already been offered enormous sums for our idea, and there are not wanting those who, finding that fair means are of no avail, do not hesitate to use foul. Both the Professor and I have been followed of late by suspicious-looking characters, and the local authorities have told off P.C. Bottlesworth to guard us wherever we go. I am afraid that the worthy P.C.'s task is rather a difficult one, for though the Professor and I frequently take walks together, his average speed is a little over two miles an hour, whilst mine is about five. The Professor, too, has a disconcerting habit of stopping to

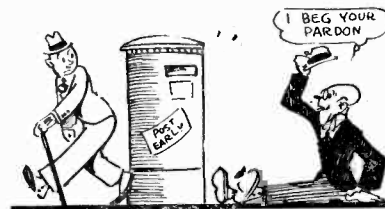

... exchanging greetings with pillar-boxes.

exchange greetings with pillar-boxes, lamp-posts and so on, which, owing to his short-sightedness, he mistakes for members of the wireless club. This, of course, still further reduces his rate of progression, and the only way that I can find of adjusting my pace to his is to follow every second step forward with one smartly executed step forward to the rear. Even this is not perfectly satisfactory, for the Professor has a way of advancing in slight curves rather than in straight lines, and I frequently knock him down as many as seventeen times in the course of one short stroll.

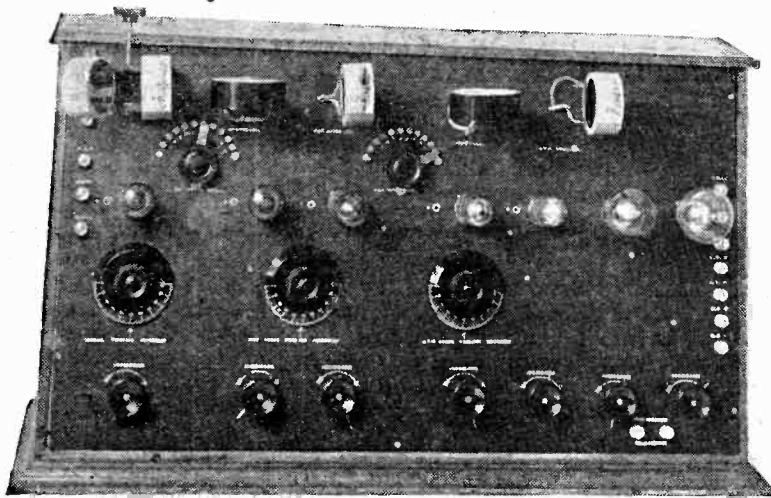

Fig. 1.—The panel lay-out is simple and symmetrical.

**THE SEVEN-VALVE
T.A.T. RECEIVER**
for
Long-Distance Reception.
Designed by
JOHN SCOTT-TAGGART,
F.Inst.P., A.M.I.E.E.

IN the set described below I have carried the T.A.T. principle to a stage where four high-frequency amplifying valves are employed, one detector valve and two note magnifying valves. The result is an extremely sensitive long-range receiver which will give truly remarkable results on the most inferior of aerials.

Appreciation

The greatest interest seems to have been aroused by the preceding articles on the subject of the T.A.T. method, which appeared in the November and December issues of MODERN WIRELESS. More letters

have been received in connection with this circuit than in the case of any circuit articles previously published by the Radio Press. The letters are unanimous in support of the claims which I have made for efficiency and stability, and I would like to take this opportunity of expressing my appreciation of letters from readers giving their results of different circuits. Such letters are not only of extreme interest to other readers, but they really contribute to a fuller appreciation of the advantages and disadvantages of different circuits under all sorts of varying conditions and in skilled and unskilled hands.

It is only by getting a very large number of letters that a true appreciation is obtained.

Multi-Stage H.F. Amplification

In the present case I have not the slightest doubt that the T.A.T. method of multi-stage high-frequency amplification will achieve very great popularity, particularly amongst those who desire two stages of high-frequency amplification. For the benefit of these latter, the set in the December issue of MODERN WIRELESS is undoubtedly the best, although a special five-valve set is in process of being designed, and will probably

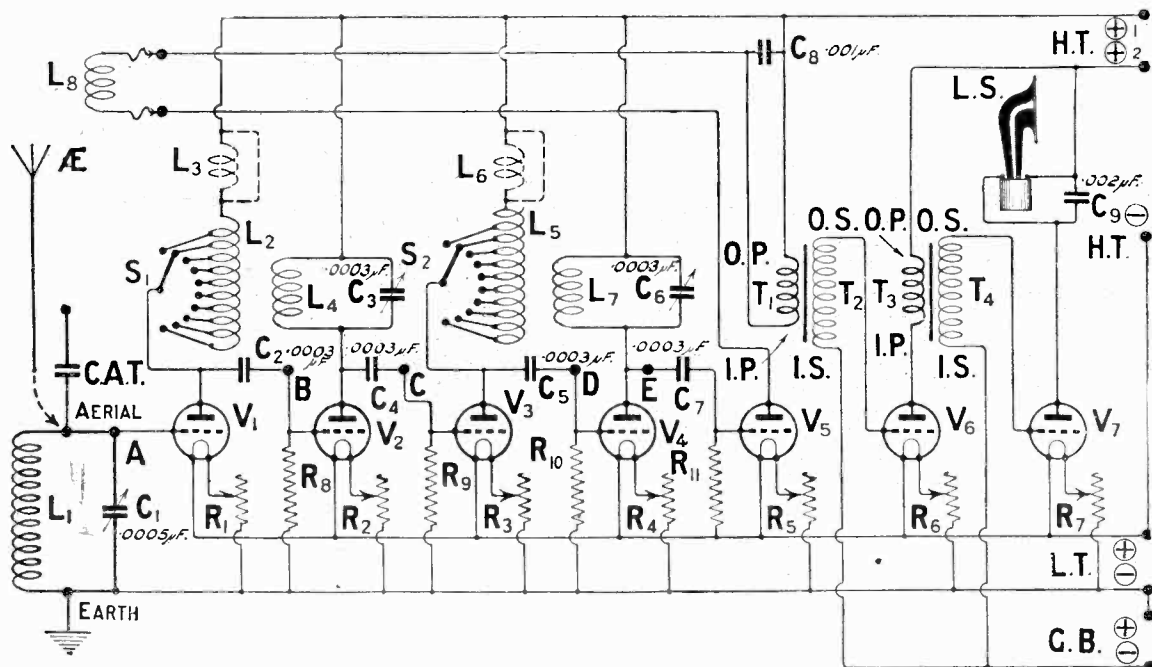

Fig. 2.—The theoretical circuit used in the receiver.

A
Distinctive
4 H.F. SET
for
Long Range
Working.

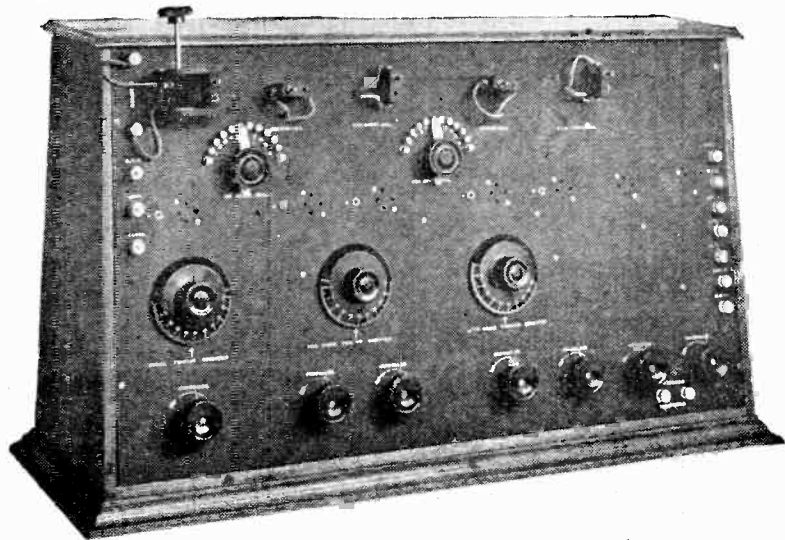

Fig. 3.—Rotary switches are used for the tapped reactances.

be described in the next issue of MODERN WIRELESS, combined with special means of increasing the selectivity. It is obviously of little use to increase the range and amplification unless selectivity is simultaneously improved, because the great trouble is that frequently, even if one receives a distant station, there is also a good deal of jamming.

Selectivity

For those who desire more than two stages of high-frequency amplification, the set described in this article will give them all they require. I believe this is probably the first article dealing with a practical set using as many as four stages of high-frequency amplification.

A test report is appended, the tests being carried out at Bedford.

The set may be used in connection with wavetraps if it is desired to obtain greater selectivity, and on certain wavelengths it may be found that the set will choke up, due to excessive amplification of incoming signals. In such cases a fewer number of high-frequency amplifying valves may be employed; the method of making the adjustment is described later.

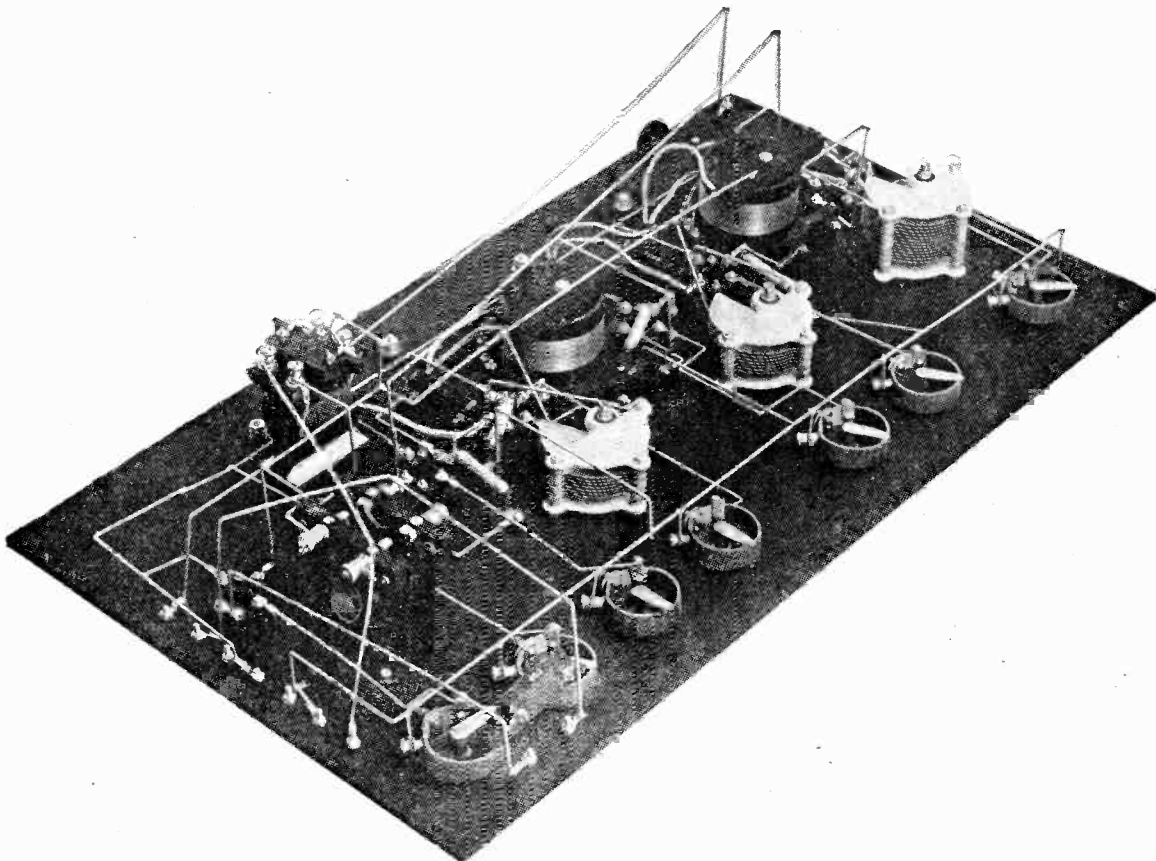

Fig. 4.—This view of the wiring shows the elevation of various leads.

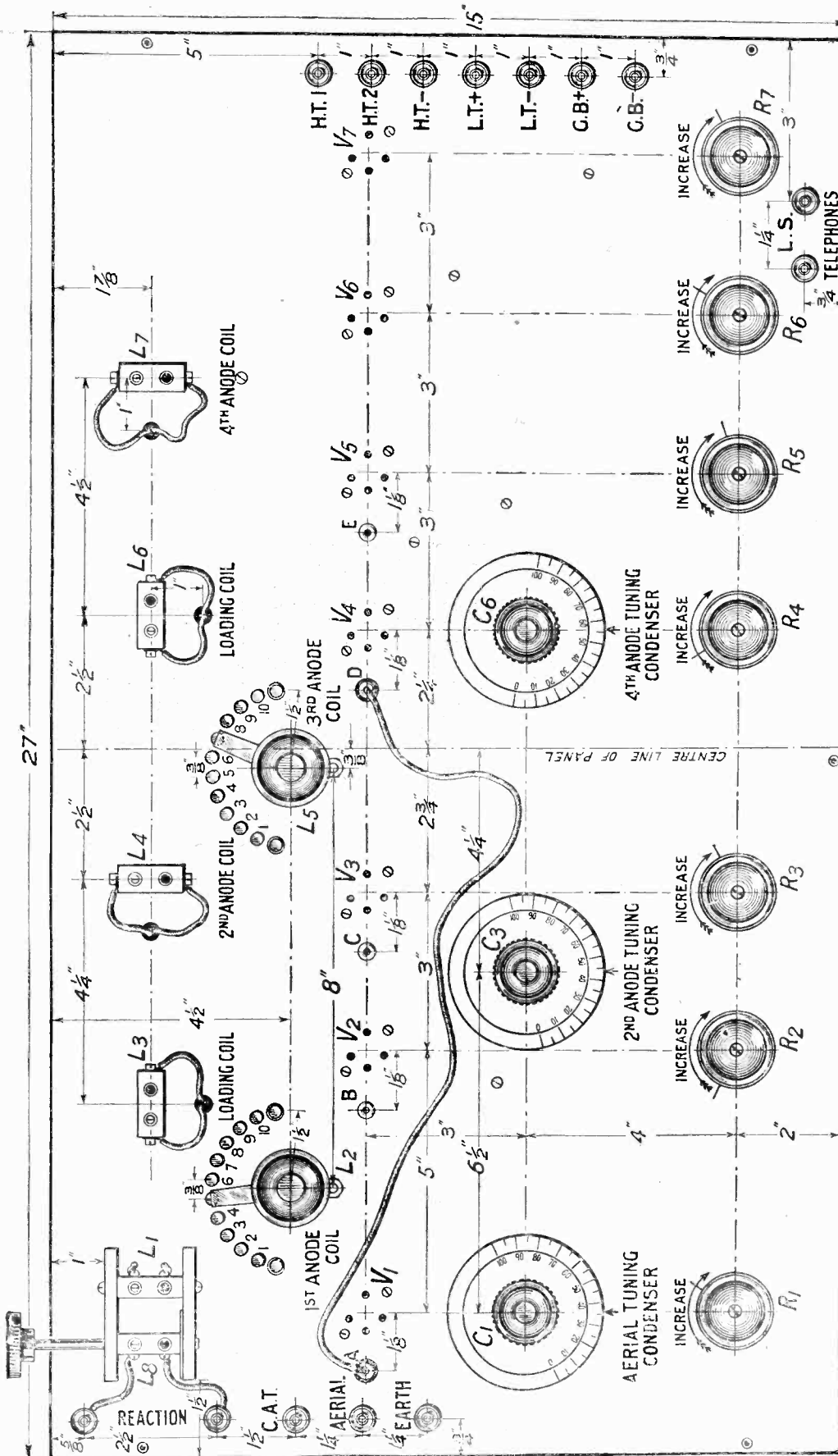

Fig. 5.—This front of panel diagram should be used for setting out and drilling the panel. Blue Print No. 85A.

I hope that all readers who make this set, or the one in the December issue of MODERN WIRELESS, will communicate to me the results which they have obtained.

In the seven-valve set described, the resistances which form an alternative aperiodic coupling have been left out, because it was considered that the number of readers who would like to receive the longer wave stations, such as 5XX, over very great distances would be very small.

A Hint to Manufacturers

With regard to the tapped reactances, it is to be hoped that manufacturers will place a suitable unit on the market which may readily be fixed to a panel, and any assistance I can give in this direction will be accorded. No doubt, some enterprising manufacturer will realise the big demand which will undoubtedly arise in connection with a suitable reactance for T.A.T. circuits.

The seven-valve T.A.T. circuit is illustrated in Fig. 2, and it will be seen that alternate anode circuits of the high-frequency amplifying valves are substantially aperiodic, and have no variable condenser in the circuit. The coils L_2 and L_5 are tapped, a description of these coils appearing later. Means are provided for inserting loading coils L_3 and L_6 in series with the reactances L_2 and L_5 , these loading coils being used for the longer wavelengths.

A constant aerial tuning condenser C.A.T. is provided, but it will be usual to connect the aerial directly on to the main aerial terminal.

Reaction

Reaction is introduced into the aerial and into the intermediate oscillatory circuit by means of the reaction coil L_8 coupled to L_1 . The coil L_8 is included in the anode circuit of the detector valve V_5 . The two valves V_6 and V_7 are low-frequency amplifiers, a loud-speaker being included in the anode circuit of V_7 . A condenser of $.002 \mu\text{F}$ capacity will usually be connected across the loud-speaker.

To cut out high-frequency valves, a flex lead terminated at each end by a Clix plug is used. One end of this lead is plugged into the socket marked A on the set, and shown in the drilling diagram. The other end is plugged into the socket B, C, D or E, according to the number of H.F. stages it is desired to use. When plugged into these sockets it is always necessary to remove the coils or shorting plugs of valves not in circuit.

Operating the Receiver

Suitable coil sizes are indicated in the test report on the receiver, and these should be plugged into the sockets indicated. A glance at the circuit diagram will show that all the H.F. valves are cut out of circuit by joining A to E. One H.F. stage is employed by joining A and D, two stages by joining A and C, three stages by connecting A to B, and the total number of four by removing the flexible lead altogether.

Tuning is carried out simply by adjustment of C_1 , C_3 and C_6 , and by varying the inductances of the first and third anode coils. The latter, of course, is effected by means of the two rotary switches. In general, ordinary tuning will be employed, the aerial being connected to the terminal marked aerial.

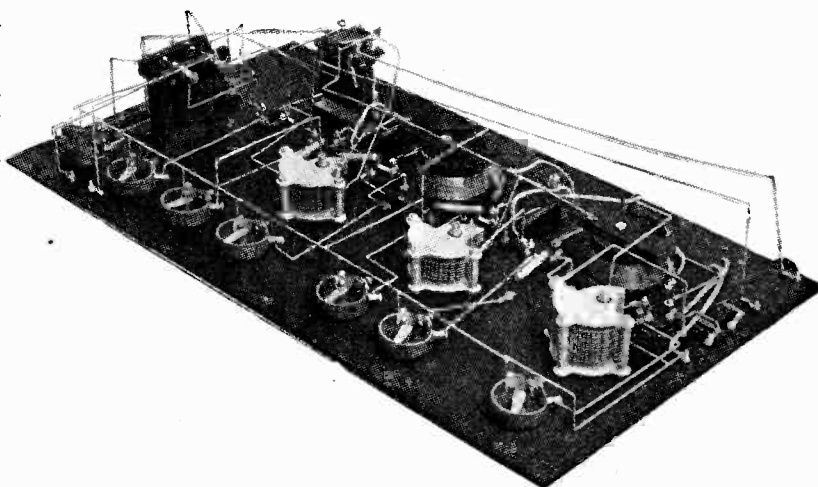

Fig. 6.—Another helpful view of the wiring.

Constructional Details

No special skill is required to make an exact copy of the set, although it certainly has a rather complicated and imposing appearance when completed. It should be borne in mind, however, that a departure from the design of the set, which has been adopted only after careful testing, is liable to affect its working and is not advised; also that all joints should be well soldered if best results are to be obtained.

Components Required

The advisability of purchasing components of good quality has often been emphasised in these pages, and applies particularly to complex receivers in which one faulty component may result in mediocre or even very poor results.

The actual components used are as follows, and makers' names are

given to assist readers who wish to exactly duplicate the receiver:—

- Ebonite panel 27 in. by 15 in. by $\frac{1}{4}$ in. (Peto-Scott Red Triangle).
- Cabinet of suitable dimensions.
- 1 "Efesca" type C. transformer (T_1T_2) (Falk, Stadelmann).
- 1 L.F. transformer (T_3T_4) (U.S. Radio Co. "Super").
- 7 valve holders (H.T.C. Electrical Co., type C.).
- 7 bright emitter valve rheostats with fuses (Shipton and Co.).
- 1 Polar Junior vernier two-coil holder (Radio Communication Co.).
- 4 adjustable single coil sockets (Penton Engineering Co., Ltd.).
- 1 $.0005 \mu\text{F}$ square law condenser ("Utility," Wilkins and Wright).
- 2 $.0003 \mu\text{F}$ square law condensers ("Utility," Wilkins and Wright)
- 4 $.0003 \mu\text{F}$ fixed condensers ("Paragon," Peter Curtis).

- 1 $.002 \mu\text{F}$ fixed condenser ("Paragon," Peter Curtis)
- 1 $.001 \mu\text{F}$ fixed condenser ("Paragon," Peter Curtis).
- 1 $.0001 \mu\text{F}$ fixed condenser (Dubilier).
- 4 2 megohm grid leaks with clips (Dubilier).
- 2 tapped reactance coils (Burne-Jones and Co. These are similar to those supplied for the "Simplicity" receiver, Envelope No. 3).
- 2 nickel plated switch arms and 20 nickel plated contact studs (Burne Jones and Co.).
- 1 ft. of 2 B.A. threaded brass rod,
- 2 pieces of ebonite, each 4 in. by 1 in. by $\frac{1}{4}$ in.
- 14 W.O. type terminals.
- 2 Clix plugs. (Autoveyors, Ltd.).
- 4 Clix sockets (Autoveyors, Ltd.).
- Square tinned copper for wiring.
- Quantity of rubber covered flexible wire.
- Packet of Radio Press Panel Transfers.

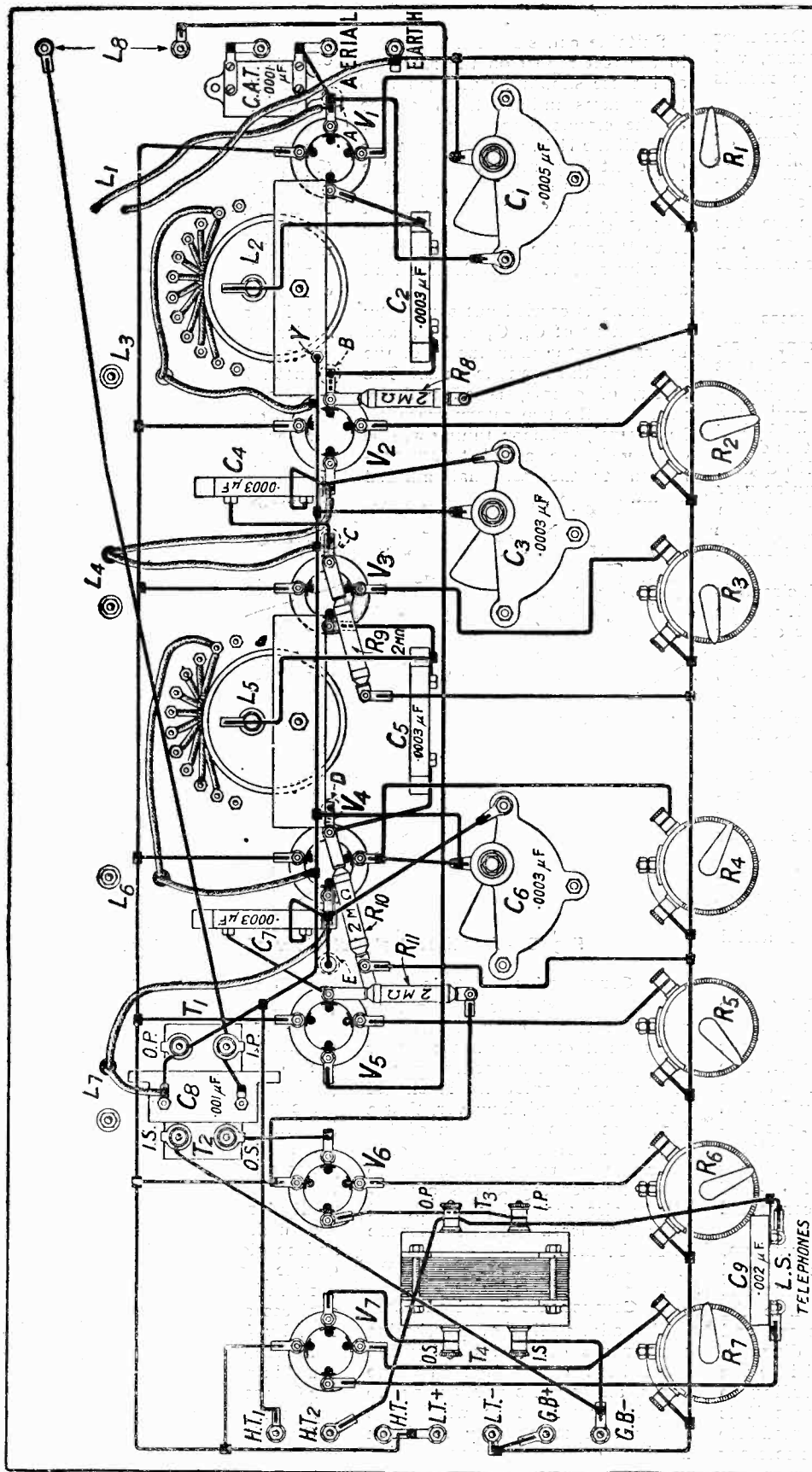

Fig. 7.—Practical working drawing of the wiring. Blue Print No. 85B.

Drilling the Panel

The diagram showing the positions of the various holes to be drilled in the panel, is given in Fig. 5. Much time may be saved by drilling all holes of one size irrespective of their positions on the panel, without changing the drill.

The Reactance Coils

The two tapped coils may be made if desired. Two formers 2 1/2 ins. in diameter by 2 ins. long, and 2 ozs. of 40 gauge single silk covered resistance wire are necessary. Each coil should be of 150 turns, tapped at 50, 60, 70, 80, 90, 100, 110, 120 and 150 turns.

Mounting the Components

The four fixed coil sockets, it will be observed, are mounted in such a manner that it is possible to rotate them and thus obtain a minimum degree of coupling between the coils they hold. The mounting, as may be gathered from the wiring diagram and photographs, comprises a 2 B.A. spindle which passes through the panel and is secured on one side in the socket itself, while on the back of the panel a spring washer and two lock nuts are employed to obtain the requisite rigidity.

The mounting of the tapped anode coils is really quite simple, the 2 B.A. rod and small pieces of ebonite mentioned in the component list being employed for this purpose. The ends of the coils having the 50 untapped turns are placed farthest from the

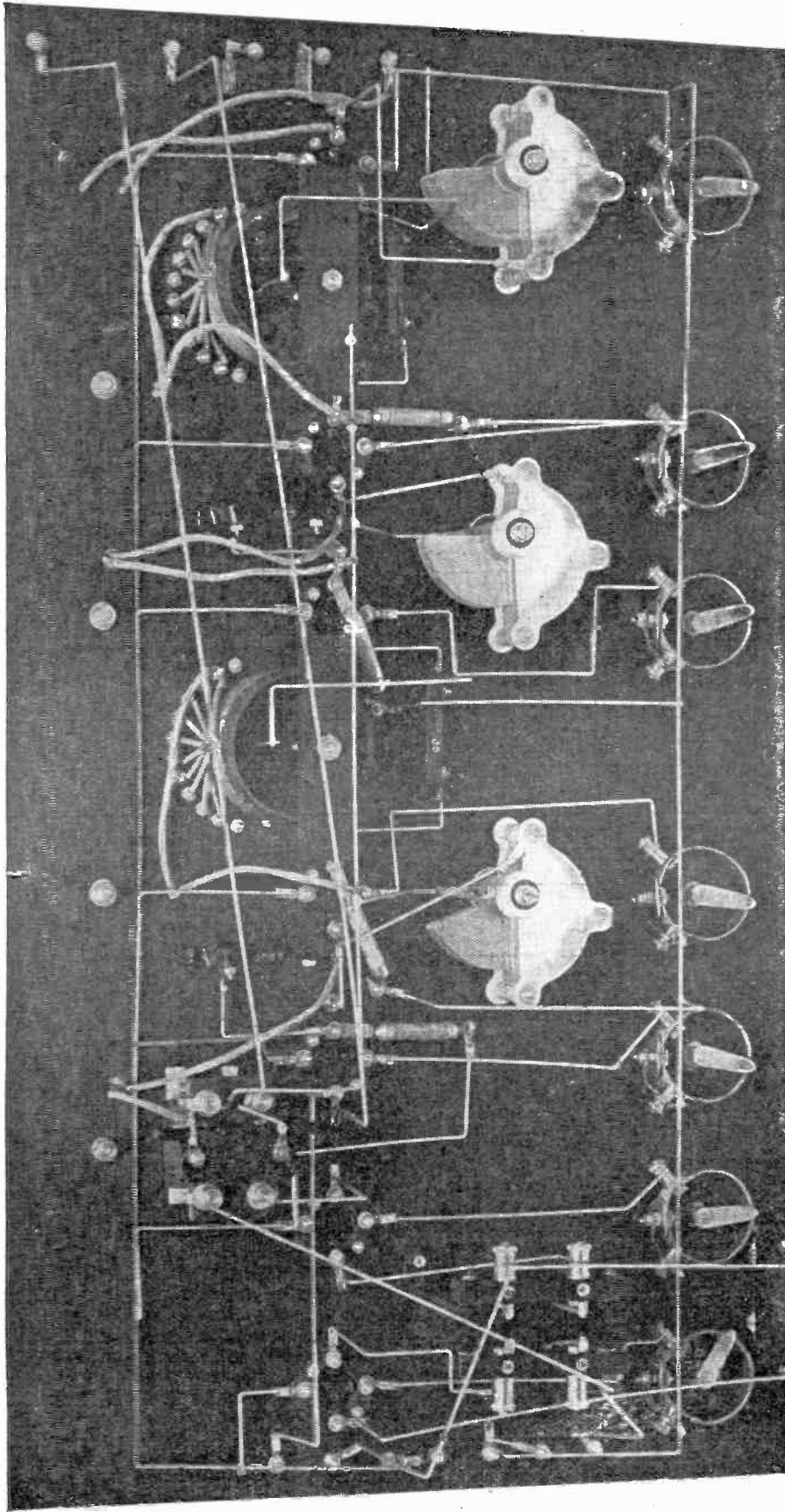

Fig. 8.—This photograph clearly shows how the leads are taken.

panel. Here again the photographs and diagrams show the method of mounting. The coil is held firmly to the panel by means of a length of 2 B.A. rod passing through the 4 in. by 1 in. piece of ebonite placed on the top end of the coil, and through the panel, a nut being fitted to each end of the rod. The clips holding the grid-leaks are in some cases fixed to grid sockets of the valve holders and in others to convenient spots on the back of the panel. These are all clearly shown in the wiring diagram, Fig. 7. In the present case, the clips have been made from sheet brass, these replacing the usual clips quite effectively.

Wiring

This should not prove difficult if method is employed in making the various connections. A careful study of the photographs giving views of the back of the panel will show which wires are near to the panel and those which are arranged on a higher level.

Soldering lugs have been used profusely in wiring this receiver, an advantage in their use being the ease with which good soldered joints may be made.

It will be observed that each fixed condenser is held in position by means of the stiff wiring to which it is soldered.

In the drilling diagram the studs of the rotary switches are numbered 1 to 10. 50 turns of the anode coil are included between studs 1 and 2, 10 turns between each consecutive pair of studs from 2 to 9, and 30 turns between 9 and 10.

At the point Y in the wiring diagram, a screw is inserted to which one of the wires is soldered for extra support. It should be mentioned that this is the sole purpose of the screw.

Tabulated Test Results.

Seven-valve T.A.T. set tested at Bedford, December 5th, 1924. Aerial used in all tests—100 ft. single wire, 45 ft. high. Parallel aerial tuning was used throughout. High tension: 78 volts on HT + 1 and 120 volts on HT + 2. Grid bias: 4 volts negative. General purpose bright emitter valves were used in the first five stages and power valves in the last two stages.

Call Sign and Wavelength.	Name.	Distance.	Grid Connections.	Values.	Aerial Coil.	Condenser.	First Anode Stud.	First Anode Choice Coil.	Second Anode Coil.	Condenser.	Third Anode Stud.	Third Anode Choke.	Fourth Anode Coil.	Porting.	Reaction.	Results.	Remarks.
2LO	London	... 50 miles	A to B	3	No. 35 Tangent	49°	—	—	—	—	—	—	No. 75 Tangent	35°	No. 50 Tangent	Very good loud speaking	Reaction coil could be coupled with very good effect
2LO	London	... 50 miles	A to D	4	No. 35 Tangent	61°	—	—	—	—	—	—	No. 75 Tangent	35°	No. 50 Tangent	Loud speaking too loud to be comfortable	Reaction loosely coupled
2LO	London	... 50 miles	A to C	5	No. 35 Tangent	69°	—	—	—	—	—	—	No. 75 Tangent	45°	No. 50 Tangent	Too powerful for the L.S.	Choking effect obtained. Changed detector valve from a Cossor to a B.T.H. B.4—better control but still overpowering the valve.
2LO	London	... 50 miles	A to B	6	No. 35 Tangent	55°	—	—	—	—	—	—	No. 75 Tangent	45°	No. 50 Tangent	Very small increase in volume	Unable to control owing to excessive choking.
2LO	London	... 50 miles	—	7	No. 35 Tangent	?	?	Shorted	No. 75 Tangent	?	?	Shorted	No. 75 Tangent	?	No. 50 Tangent	Excessive choking	No interference from London.
3WA	Cardiff	... 120 miles	A to C	5	No. 35 Tangent	36°	—	—	—	—	—	—	No. 75 Tangent	30°	No. 50 Tangent	Good loud speaking	
3WA	Cardiff	... 120 miles	—	7	No. 35 Tangent	?	?	Shorted	No. 75 Tangent	?	?	Shorted	No. 75 Tangent	?	No. 50 Tangent	London flooding and completely paralysing the set although no actual signals from London were received	
2ZY	Manchester	... 120 miles	A to C	5	No. 35 Tangent	82°	—	—	—	—	—	—	No. 75 Tangent	46°	No. 50 Tangent	Good loud speaking but slight interference from London.	
2ZY	Manchester	... 120 miles	—	7	No. 35 Tangent	?	?	Shorted	No. 75 Tangent	?	?	Shorted	No. 75 Tangent	?	No. 50 Tangent	Unable to tune owing to choking effect of London station (no actual signals received from 2LO).	
6BM	Bournemouth	... 120 miles	A to C	5	No. 25 Tangent	90°	—	—	—	—	—	—	No. 75 Tangent	49°	No. 50 Tangent	Very good loud speaking but slight interference from London.	
6BM	Bournemouth	... 120 miles	—	7	No. 35 Tangent	?	?	Shorted	No. 75 Tangent	?	?	Shorted	No. 75 Tangent	?	No. 50 Tangent	London paralysing the set.	
5NO	Newcastle	... 200 miles	A to C	5	No. 50 Tangent	10°	—	—	—	—	—	—	No. 75 Tangent	51°	No. 50 Tangent	Good loud speaking.	
5NO	Newcastle	... 200 miles	—	7	No. 50 Tangent	11°	Stud 8	Shorted	No. 75 Tangent	—	—	Shorted	No. 75 Tangent	50°	No. 50 Tangent	Full loud speaking	
5SC	Glasgow	... 300 miles	A to C	5	No. 50 Tangent	15°	—	—	—	—	—	—	No. 75 Tangent	56°	No. 50 Tangent	Good loud speaking	
5SC	Glasgow	... 300 miles	—	7	No. 50 Tangent	19°	Stud 9	Shorted	No. 75 Tangent	54°	Stud 10	Shorted	No. 75 Tangent	56°	No. 50 Tangent	Very good loud speaking	
5IT	Birmingham	... 65 miles	A to C	5	No. 50 Tangent	57°	—	—	—	—	—	—	No. 35 Tangent	71°	No. 50 Tangent	Very good loud speaking	
5IT	Birmingham	... 65 miles	—	7	No. 50 Tangent	?	?	Shorted	No. 75 Tangent	?	?	Shorted	No. 75 Tangent	?	No. 50 Tangent	Set paralysed	
2BD	Aberdeen	... 350 miles	A to C	5	No. 50 Tangent	66°	—	—	—	—	—	—	No. 50 Tangent	79°	No. 50 Tangent	Very good loud speaking	
2BD	Aberdeen	... 350 miles	—	7	No. 50 Tangent	?	?	Shorted	No. 75 Tangent	?	?	Shorted	No. 75 Tangent	?	No. 50 Tangent	Birmingham paralysed the set, although no actual signals were received from this station.	
5XX	Chelmsford	... 45 miles	A to E	3	No. 150 Lissen	65°	—	—	—	—	—	—	No. 200 Lissen	—	No. 200 Lissen	Very good loud speaking.	
5XX	Chelmsford	... 45 miles	A to D	4	No. 150 Lissen	81°	—	—	—	—	—	—	No. 200 Lissen	80°	No. 200 Lissen	Uncomfortable loud speaker strength. Set overpowered if more than this number (4) of valves was used at the distance.	Excessive interference from Morse.



VILLAGE GROECER (WHO HAS JUST INSTALLED IT):—
"WE ARE NOW CLOSING DOWN UNTIL 8-30 TO-MORROW
MORNING — GOOD NIGHT EVERYBODY — GOOD-NIGHT!"

A SIGN OF THE TIMES.

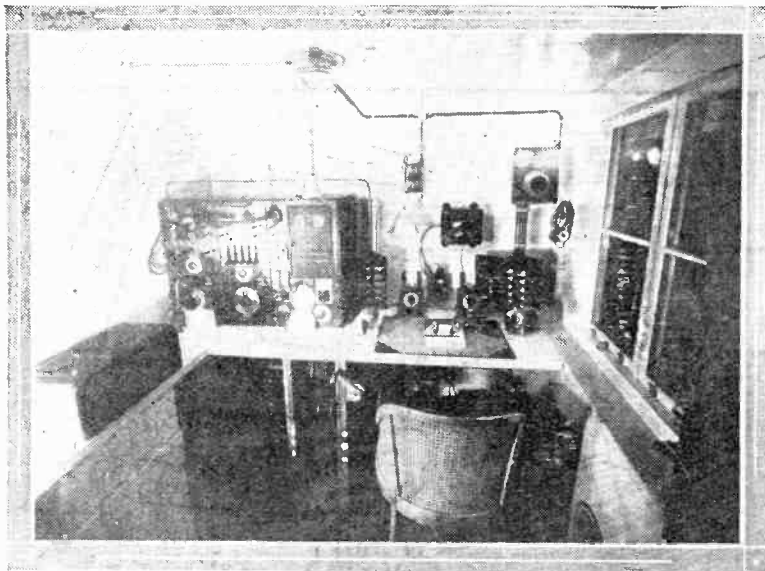

The wireless room on board the ZR-3, showing the transmitting and receiving apparatus.

THE safe conclusion of the Transatlantic voyage of the ZR-3 would never have been possible without complete and efficient wireless telegraph and telephone equipment. There are so many factors entering into the proper navigation of such a huge aerial transport device that safe navigation of it over such extreme distances would not be possible if the navigating officers were not in touch with various sources of information at all times during the voyage.

The weather conditions alone are of such extreme importance, that even the direction of the course of such a ship is dependent upon minute and voluminous weather information which must be obtained from authentic sources.

The Wireless Compass

An entirely different situation confronts the captain of a dirigible than that of the skipper of a steamship in the point of navigation. The salt water officer has always his sextant, his log and sometimes landmarks. The aerial skipper is not so blessed with means of finding his way about. Consequently his every position and even his course is checked by the use of the wireless compass. Without this highly sensitive piece of apparatus, there would be no end to his difficulties in knowing where he was at any given time.

How the ZR-3 was Piloted by Wireless

By Captain H. C. FLEMMING, Chief Wireless Operator of the ZR-3.

So, considering these few factors alone, it is easily understood why such sensitive wireless equipment was included in the cabin of the ZR-3.

The Main Transmitter

The apparatus consisted of five distinct units. There was the regular transmitter of 400 watts capacity capable of working on wavelengths between 300 and 3,000 metres. This set was of the standard valve transmitter type so arranged that it could be operated upon C.W. or I.C.W. This was the transmitter which was relied upon during the greater part of the journey to furnish connection with the outside

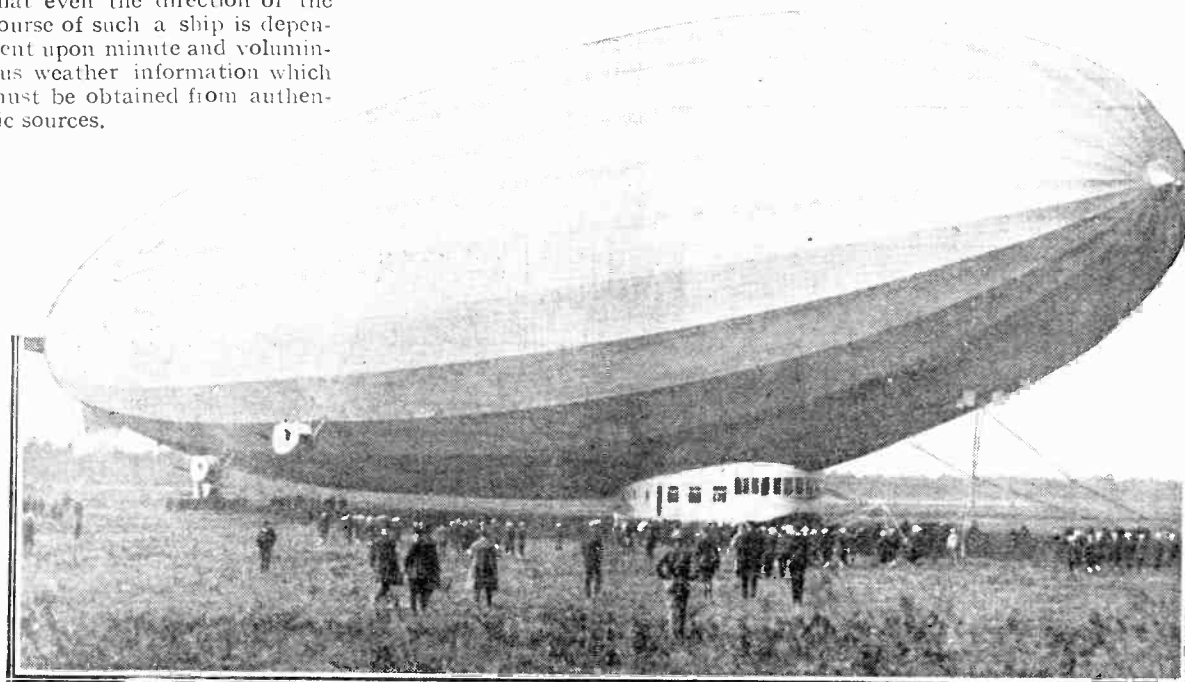

This picture was taken at the landing of the ZR-3 after its successful flight from Germany to the U.S.

In this fascinating article the chief operator on the ZR-3 graphically describes how wireless, to a large extent, made possible this epoch-making flight from Friedrichshafen to New York.

world. It had a proven range of about 1,400 miles for dependable communication.

Power Supply

Power was furnished by a $1\frac{1}{2}$ kilowatt, wind-driven generator, which was arranged to swing out from the side of the cabin. A novel method of adjusting the speed of the generator to the speed of the dirigible was obtained through this system of raising and lowering the generator unit in regard to the side of the cabin. By changing the angle, proportionate changes in speed could be obtained, thus enabling the operators to obtain the proper voltage from the generator at all times. The air currents created by the speed of the dirigible, of course, furnished the power for turning the propeller which was directly connected to the shaft of the armature. The voltage from the generator was stepped up to 3,000 volts through a transformer and then rectified by the usual valve rectifier. After passing through a series of filters it was impressed on the plates of the transmitter valves. Power for lighting the filaments of these was also obtained from the wind-driven generator through the agency of a step-down transformer.

The Receivers

The bulk of the receiving on the Transatlantic voyage was accomplished on a detector and two low-frequency set of a standard German make. Two of these sets were used jointly. The arrangement was of the ordinary reaction type. For general work this set was found to be thoroughly reliable.

The most novel piece of apparatus was the radio compass, which contains besides the detector and two stages of audio frequency amplifica-

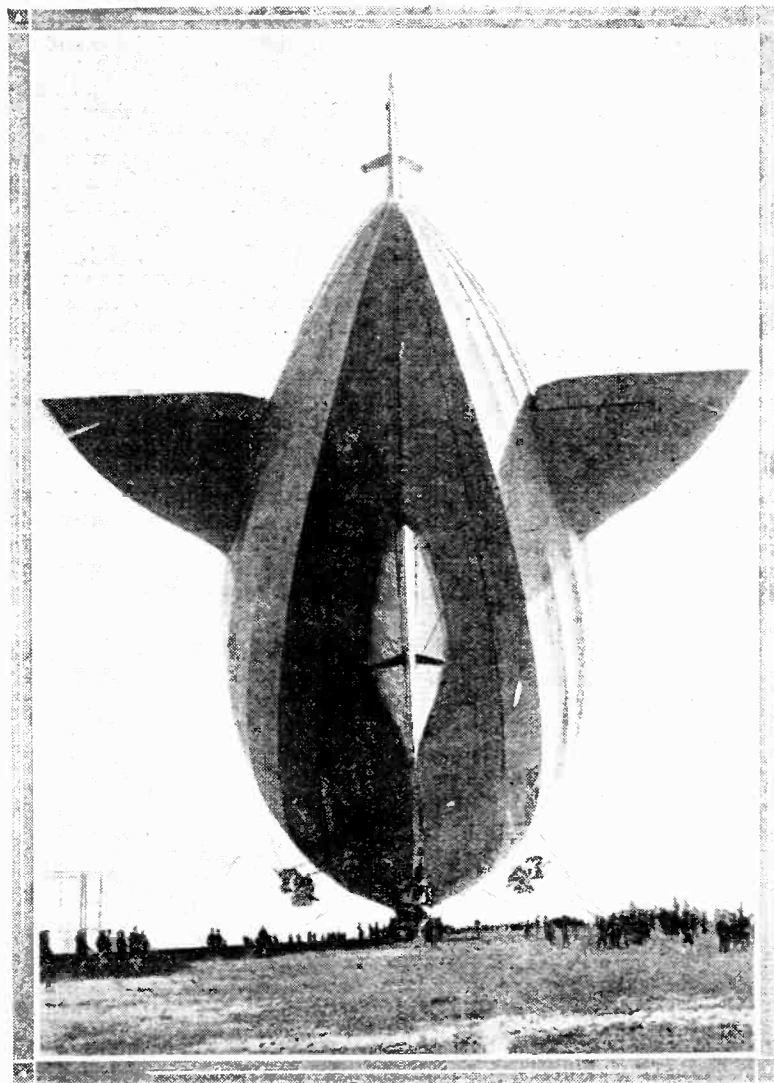

The aft cabin in which the operating room was located is seen in this photograph.

tion, six stages of radio frequency amplification. Obviously, this set is extremely sensitive, and purposely so, since several times en route the captain took recourse to it in order to check his position and bearing. As a matter of fact, he used it upon every occasion, for the radio compass is the one arrangement which may be absolutely relied upon for accuracy. Through the use of a uni-directional loop, it was possible with this compass to obtain a course by taking observations on one known point alone. This is a great improvement over previous installations which require that two points be located and then the position or course of the ship is obtained by triangulation.

The Telephony Transmitter

The wireless telephone installation was comparatively small, being of about 50-watts capacity, since it

was intended primarily for use when making landings. The only efficient way by which the captain of such a ship may direct his ground crew in making a landing is through the use of wireless telephony; other means of signalling, such as the semaphore system, might conceivably be used, but wireless is the only practical method.

An Emergency Spark Set

A reserve set installed for use in case of an emergency was of a standard Telefunken quenched-spark type capable of working on waves between 300 and 800 metres. During the voyage this set was kept in working condition so that it could be brought into operation at a moment's notice, in case of major damage to the regular valve transmitter. Of course spare parts were carried to replace practically any breakdown.

The filament current for the receiving valves, as well as the plate supply, was obtained from storage batteries charged by the wind-driven generator.

The Operating Room

The operating room itself was in the aft cabin. A peculiar method of construction was employed so that the room was both sound and shock proof. The terrific roar of the engines was deadened by a wax compound lining which covered the entire interior. Several precautions were necessary in installing the apparatus so that all danger from sparks would be eliminated; even the transmitting valve was surrounded by wire gauze which would protect any spark originating at the contact points from igniting stray gases which might have been present. Similar precautions were taken at every point in the ap-

any combination of them together. Their total length was 360 feet. A torpedo shaped weight hung from the bottom of each one and was of sufficient size to keep them taut.

The Departure of the ZR-3

At 6.35 GMT, on the morning of October 12, the ZR-3 departed from Friedrichshafen on Bodensee for its voyage to the U.S. Naval Air Station at Lakehurst, N.J. Apart from the crew of seven men there were aboard the ship three naval officers and a representative of the U.S.A. No passengers were carried on the ship, since every extra ounce of lifting capacity was given over to carrying the 30 tons of benzine, two tons of oil and a ton of food.

In the morning before our departure a heavy fog descended on Friedrichshafen so that the thousands of people who had gathered to see us take off were

was, therefore, with great interest that the first operator took his place and began tuning the receiver.

First Transmission

This first attempt was unsuccessful, since one of the three aerial wires snapped before we were able to work with the home station at Friedrichshafen, which we were calling. What repairs were possible were made on the broken wire and later, as we were passing over Basel, Switzerland, we succeeded in getting into communication with Friedrichshafen, working on 1,510 metres. Of course the first messages were for the Press. Following these there was a large number of weather reports detailing the atmospheric conditions along the first part of our proposed route. It must be noted here that these first reports caused us to change our course. At first we had intended to fly south to the Gulf of

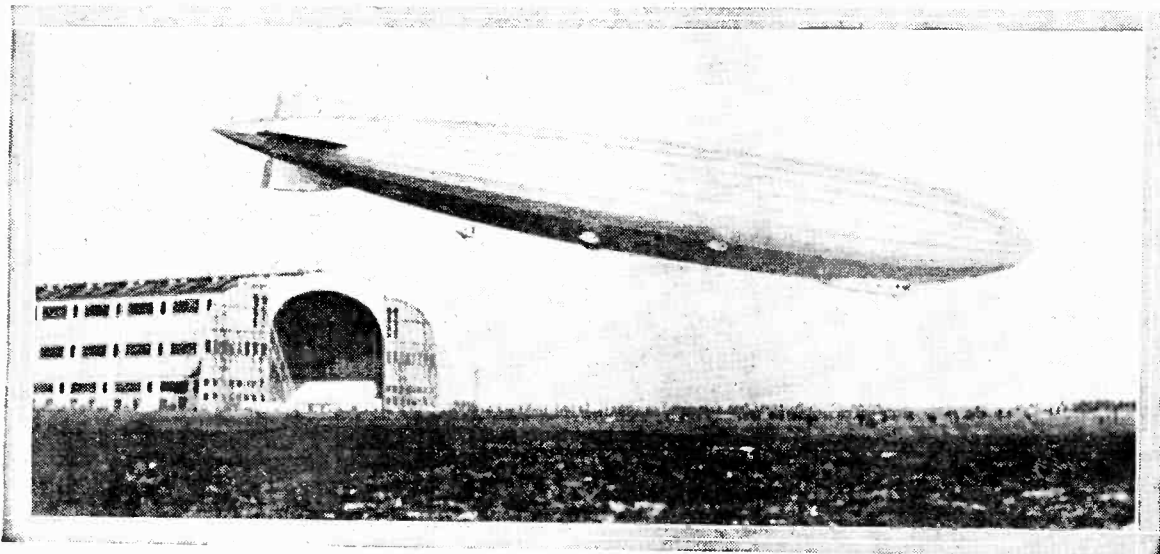

The special telephony set installed on board was primarily for use when landing.

paratus where there was a possibility of an open discharge. On every occasion when the ship was taken to a higher altitude, the operators were notified to cease transmitting, since each rise in altitude was accompanied by a slight escape of gas, and the gas being hydrogen was, of course, highly explosive. At the conclusion of the rise, when the captain thought it safe, he would signal the operators again to resume their work.

The Aerial

The aerial system consisted of three stranded cables of the Litz type. Each wire was attached to its individual winch and could be lowered or raised independently of the others. Through a switching arrangement the operators were able to use any wires separately or

unable to watch the ship more than leave the ground.

The take off was accomplished without event. The early part of the voyage was made through the clouds and fog. Soon, however, the ship was piloted to a height of 2,200 feet, and we passed above the clouds. The Swiss Alps appeared in the morning sun. Almost immediately the aerial was lowered and the apparatus started. Before we left complete weather reports had been received daily for more than two weeks, covering the course over which we intended sailing. It was of the utmost importance to keep in close touch with any changes which took place in the weather along the route, and that we were immediately notified of any unknown circumstances. It

Lyons and then cross over the Spanish Peninsula. However, after the reception of these first messages, we changed direction and headed for the mouth of the river Gironde in France and thence across the headland of the Spanish Peninsula.

Among the stations furnishing us this very necessary information was Deutsche Seewarte, Hamburg Marine Information Bureau. Messages from this source came by way of Nauen, call OUI, and were transmitted on a wave of 1,460 metres. These reports, which were sent four times a day (at 5 a.m., 11.05 a.m., 5 p.m. and 10 p.m.) were supplemented by others from Eiffel Tower station in Paris, call sign FL, and the United States Naval Station at Arlington, Va., call sign NAA. The United States

station at Annapolis also furnished us with a further report of conditions on the American side of the Atlantic.

Naval Assistance

The transmission of the reports was by no means the largest part of the job. The conditions had to be observed. For this purpose the United States Navy provided three ships which were placed at points along the course that we were to take, and weather officials on these craft made observations, which were transmitted direct to us, or at times when the stations aboard the observing vessels were unable to make connection with us, relayed their reports to the Annapolis or Arlington station.

Apart from the weather reports, the time signals sent out from Nauen and Eiffel Tower were of great importance. With the aid of these, the chronometers of the ship were checked.

Prearranged transmissions

Previous schedules of transmission had been arranged before the departure of the ship. That is to say, a number of stations were to be listening for our call at certain hours of the day, so that we would be able to send out wireless correspondence with the greatest ease and despatch. The hours between 1 and 2 a.m., 7 and 8 a.m., 1 and 2 p.m., and 6 and 7 p.m. were to work with Norddeich, KAV, Germany, and from 2 to 3 and 8 to 6 a.m. and 7 to 8 p.m. we made connection with Bar Harbour, NBD, in the United States.

Some idea of the huge amount of weather information which had to be handled may be gained from the fact that the transmitter was comparatively quiet during our passage over France, for during this time the operators were busily engaged in receiving the reports.

B.B.C. Interference

Immediately we left the French mainland and started for the point off Spain, heavy wireless traffic began. All three operators were kept busy at the apparatus. Matters were not improved by the fact that many liners along the route of the voyage across the Atlantic took occasion to call us, wishing us good luck. While passing over Spain all wireless work became extremely difficult on account of interference from the British Broadcasting Stations.

Difficult Working

The following morning, shortly after midnight, a very bad period of

wireless weather set in, during which we worked the stations at Eilvese and Norddeich with extreme difficulty. Even when we put the radio compass into service with its six stages of radio frequency amplification, we could not obtain satisfactory results. This condition maintained for several hours. At 8 a.m., however, the air cleared, and for fifty minutes we enjoyed what might be termed perfect working conditions. During this time we obtained an answer from Norddeich and succeeded in working off most of the constantly mounting pile of messages.

During this period we passed the steamer *City of Boston*. She signed herself GFRG, and was so kind as to give us her position—30 degrees 18 minutes N. Lat. and 49 degrees 16 minutes W. Long.—by which the captain checked his observation of our own course.

On approaching the Azores, reports came in from Ferinca, and at 2.30 a.m. we left the islands aft and started directly for Lakehurst. At this time the wind was in the west and was growing constantly stronger. It was only a matter of minutes until we were called by

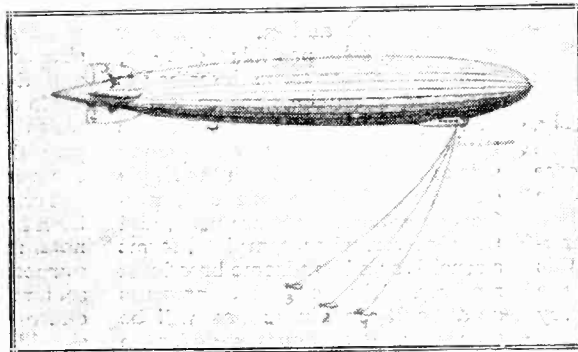

Different weights cause the aerial to spread fan-shape.

the *Detroit* and told that a low point of barometric pressure was located just off the point of Newfoundland. With this information, the course was changed accordingly in order to avoid it.

Atmospherics and Morse

It was about this time that our difficulties in the wireless room became really acute. First, we were proceeding at about ninety miles per hour. After the change in course it was only a short time before the clear sky under which we had been sailing for the past ten hours gave way to dense clouds. Previously we had been in constant communication with the *Detroit* through the aid of the wireless compass. As we proceeded, reception became constantly more

difficult on account of atmospheric. But this was not the worst. All the ships along our course were working, and created no end of interference. NERM—the call assigned to the ZR-3—called many of them time after time, giving the international signal, QRM, which means "you are interfering, please use less power or cease transmitting," which had not the slightest effect. Conditions finally became so bad that it was impossible to continue with the work. It was decided that the working wavelength should be changed. To no avail, however, since we found as much interference on the higher wavelength as previously. There were a number of ships carrying spark equipment which were quite bad in this quarter. They created constant QRM at all wavelengths. It was principally through the kindness of WSO and WCC that we were able to get through our quota of traffic.

The Landing

As we approached the American shore matters righted themselves, and by the time we were passing over New York our business was cleared and the wireless staff was quite ready to make landing. Of course, the telephony equipment was gone over and placed, ready to stand-by for the landing operations. However, this preparation was not necessary since the crew at the field handled the situation with perfect ease.

Not the least enjoyable features of the journey was the reception of programmes from various broadcasting stations. One of the officers of the ship produced a loud-speaker which worked with the conventional horn and without additional power of any kind. During the trip a little more than 12,000 words were handled in code. This record was made in spite of the great number of repeats and the extremely bad atmospheric conditions.

As for the range of our transmitter, WSO heard us while we were flying over Basle, Switzerland. The *New York Times* station picked up our signals while we were cruising over the Spanish shore. A peculiar thing in connection with this station's performance was the fact that the *Times* station reported hearing us just as well while we were in Europe as it did while we were passing over New York City.

In spite of the difficulties encountered on the journey, the station worked very satisfactorily.

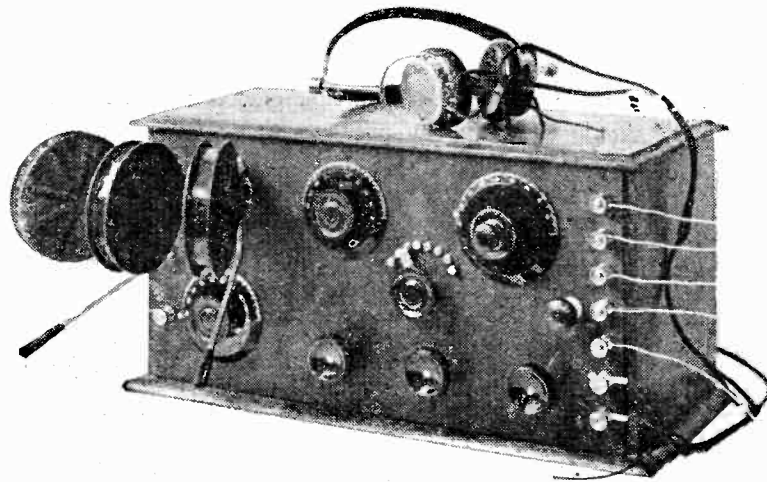

Fig. 1.—Valves are enclosed in this compact receiver.

A Three-Valve “Neutral-Grid” Receiver.

By

JOHN W.
BARBER.

MUCH interest has been aroused among experimenters by the publication in *Wireless Weekly* of an article by A. D. Cowper, M.Sc., describing the “Neutral-Grid” method of coupling a high-frequency amplifying valve to the detector valve, and many will no doubt have tried the arrangement.

The principle, for the benefit of those who may not have seen the original article, is, briefly, as follows: In a tuned-anode circuit the capacity coupling in the valve itself is often sufficient, with well-designed inductances, sharply tuned, to cause the set to oscillate freely, without the aid of intentional reaction. When this is the case the circuit has to be stabilised in some way, the most common method being by the introduction of damping in one form or another, this reducing the efficiency of the first valve as a high-frequency amplifier.

The Neutral Tapping

Considering the case of a loosely coupled aerial circuit, if the grid coil be connected, not across grid and filament, but across grid and a tapping point at or near the centre of the anode tuning coil, the grid circuit will, theoretically, be held neutral with respect to oscillations in the anode circuit, and the set will thus be stabilised.

In practice, however, the grid-filament capacity of the valve is generally larger than that between the grid and anode of the valve; therefore the tapping-point will be displaced from the centre of the anode coil, and will be located nearer to the “H.F. earth” (H.T. +) end of that coil.

We now have an oscillating circuit interposed between the tapping-point and the grid of the valve,

and this circuit will be unaffected by oscillations in the anode coil. The oscillations in the grid coil will, however, by the action of the valve, appear in magnified form in the anode circuit. Reaction may be introduced into the grid coil from the anode circuit of the detector valve, and thus a three-coil tuner is a necessity.

Circuit Details

In his articles in *Wireless Weekly*, Vol. 5, Nos. 2 and 3, Mr. Cowper gave several possible circuits, and the receiver to be described is modelled upon the lines of Fig. 4 of No. 3, with some modifications in respect of the low-frequency side of the circuit. With the single exception of the anode coil, perfectly standard parts are used, and the receiver, when complete, forms a sensitive and handsome broadcast receiver. The coil L_3 presents no difficulty in winding, as will be seen later. Provision is made for the inclusion or omission of the note-

magnifying valve, the change being effected by means of a Bretwood anti-capacity switch, the connections to which are clearly seen in Fig. 8. The switch cuts off the filament supply to the last valve and changes over the telephones.

Parallel Tuning

Separate anode voltage supply to the note magnifier is made possible by the inclusion of a separate terminal HT+2, that marked HT+1 being a common supply for the high-frequency and detector valves.

No advantage has been found in series aerial tuning, so that no provision for such has been made, the parallel method being adopted.

Terminals for grid bias have not been included, as with one stage of note magnification, using general purpose valves, external grid bias is seldom necessary, provided the anode voltage is not unduly high; but should the experimenter desire to introduce a biasing battery, the

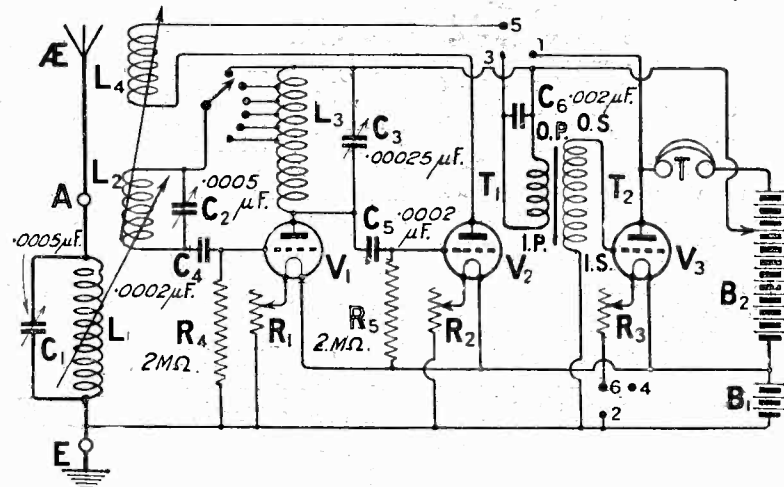

Fig. 2.—The theoretical circuit; the numbered leads go to the switch shown in Fig. 8.

An
All-Round Receiver
employing a
Circuit described
in
"Wireless Weekly,"
Vol. 5, No. 2.

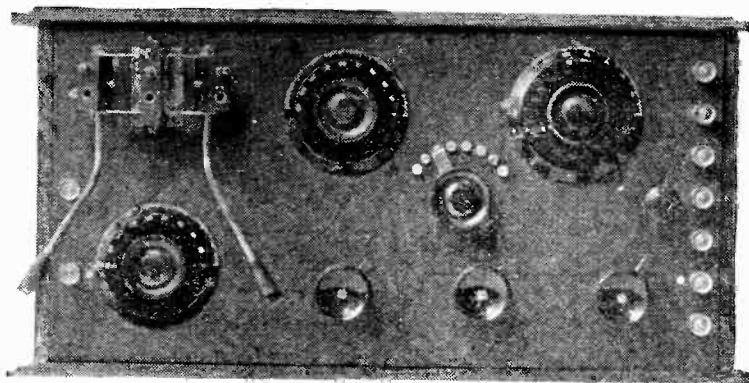

Fig. 3.—Simplicity is the keynote of the panel layout.

lead from the I.S. of the low-frequency transformer to L.T.— is taken out, and the I.S. is connected to the negative terminal of the grid battery, the positive terminal of which is joined to L.T. —.

Components Required

For the benefit of those readers who desire to construct this receiver, the necessary parts are listed below, and as some may want to know the names of the actual parts used, these are added. It is not essential that the constructor should use the parts named, any of good quality being satisfactory; values, however, should be strictly adhered to.

- 1 Cabinet (All Concert-de-Luxe type).
- 1 Ebonite panel, 16 in. by 8 in. by $\frac{3}{4}$ in.
- 1 Ebonite strip, 14 in. by $1\frac{1}{2}$ in. by $\frac{1}{4}$ in.

- 2 0.0005 μ F Variable condensers (Jackson Bros. square-law type).
 - 1 0.00025 μ F Variable condenser (Sterling square-law with vernier).
 - 1 3-way Coil-holder (Magnum).
 - 3 Filament resistances (Shipton).
 - 1 Low-frequency transformer (Super-Success).
 - 3 Valve sockets (H.T.C., Type C.).
 - 2 0.0002 μ F Fixed condensers (Dubilier).
 - 2 2MO Leaks (Dubilier).
 - 1 0.002 μ F Fixed condenser (Dubilier).
 - 1 Switch arm, $1\frac{1}{4}$ in. radius (McMichael).
 - 6 Studs, 2 stops.
 - 9 Terminals (Magnum, nickel-plated).
 - 1 Ebonite tube, 4 in. diameter, 5 in. long (Britannia Rubber Co.).
- About $\frac{1}{2}$ lb. of No. 20 S.W.G., D.C.C. copper wire.

- 1 Anti-capacity switch (Bretwood).
- Some wire for connections and flex for leads to coil-holder.

The Anode Coil

This is very simple to construct and may be wound in any manner convenient. Tappings are required from the last six turns. The method I adopted in making the tappings may seem unnecessarily complicated, but in reality is very simple and gives a neat job with no soldering, excepting on to the studs of the selector switch.

First wind on 85 turns and cut the wire adrift from the remainder on the bobbin. Remove 11 turns and drill a hole in the ebonite tube at the point where the tapping is to be taken. The free end of the wire is threaded through and pulled tight, when the end is passed *back again* through the hole, until a loop about three inches long remains inside the tube. A turn is now wound on and the procedure repeated, the last turn being threaded in one hole and out through another, thus effectively securing the wire in position. The extra five turns put on over and above the 80 necessary will be found ample for the tappings. Those who prefer may wind on 80 turns straight off and then make the tappings by scraping the insulation off each turn for a small portion and soldering a wire on at each point.

Drilling

The design of this receiver is such that only the operating controls are on the main panel, the valves being mounted upon a sub-panel at the back out of harm's way. The method of drilling the main panel is seen in Fig. 5, which gives all the necessary dimensions. The sub-panel is only to be drilled to take the three valve-holders

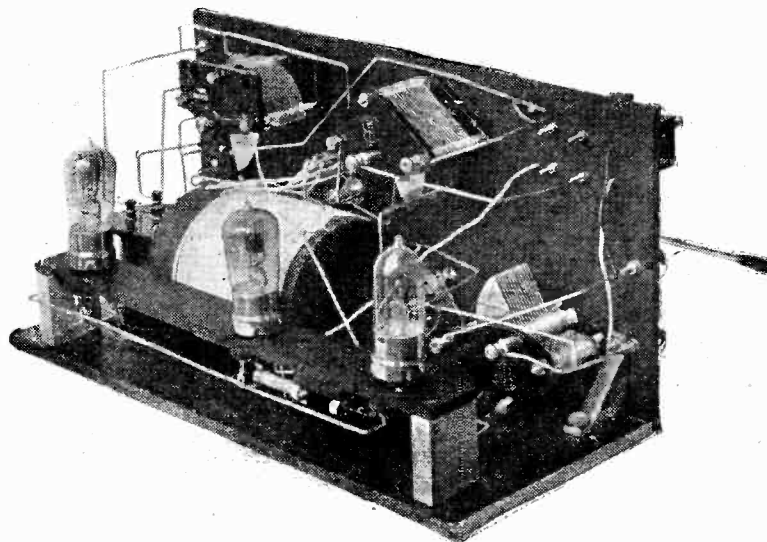

Fig. 4.—This photograph shows the connections to the "Neutral-Grid" coil.

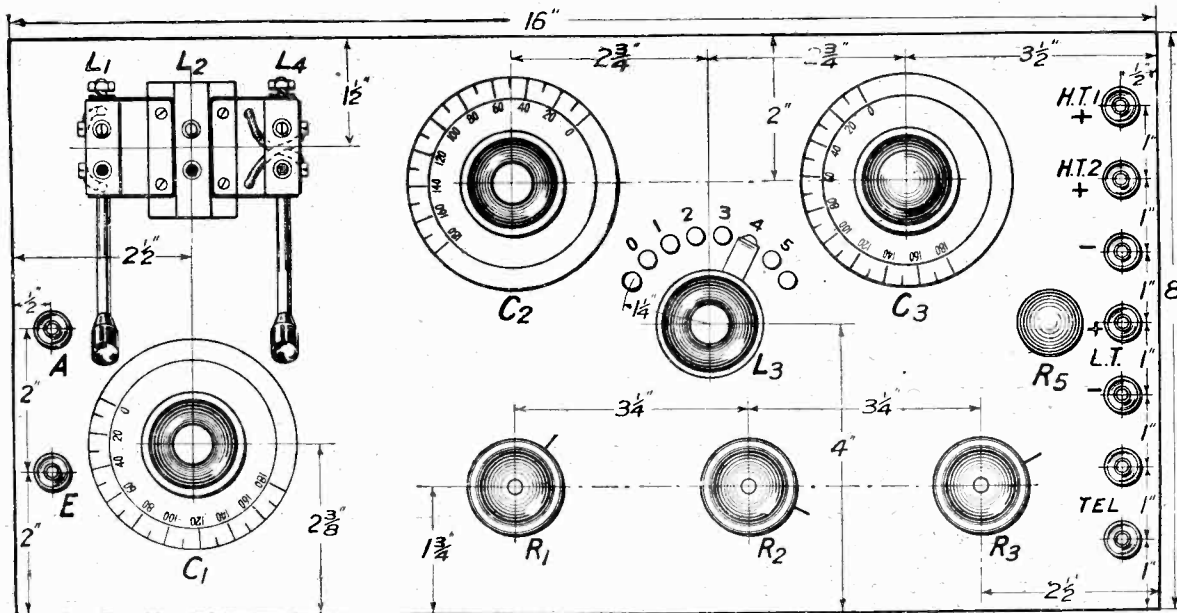

Fig. 5.—Front of panel drilling diagram. Blue Print No. 87A.

and one fixed condenser. The former may be drilled from the templates supplied, while the holes for the condenser may be drilled, using the component itself as a template. The sub-panel is mounted upon two pieces of wood which are secured to the base-board, the latter being in turn secured to the main panel by means of a stair-rod bracket at each side. Very few holes are required on the main panel, and no difficulty is anticipated in this direction. The low-frequency transformer is screwed directly on to the base-board.

Wiring

The wiring of the receiver may need a little care, owing chiefly to the leads to the sub-panel, but if the wiring diagram (Fig. 7) is carefully followed, the task need not present any difficulty. Either round or square section wire may be used, as preferred, and I recommend that wiring actually on the main panel be carried out first, the leads to the sub-panel being fitted and soldered first to it; afterwards connections are completed to the main panel.

Valves

Any good make of general-purpose receiving valve will give satisfaction in this receiver, and the maker's instructions regarding filament and anode voltages should be carefully followed. If dull emitter valves are employed suitable rheostats must be incorporated. As the receiver was intended for use with such valves, the resistances are of the 30 ohm type.

Coils
For the broadcast waveband from 300-500 metres a No. 35 or 50 coil will be required in the aerial socket L_1 . L_2 and L_4 may each be a No. 50, or a No. 50 and 75 respectively. The coil L_3 , as wound, will cover this band with

the condenser used, but clearly a larger coil will be required if the set is used on the higher wave signals such as those of Chelmsford or Radio-Paris. The chief object of the principle is, however, stability on the ordinary broadcast waveband, as other methods of high-

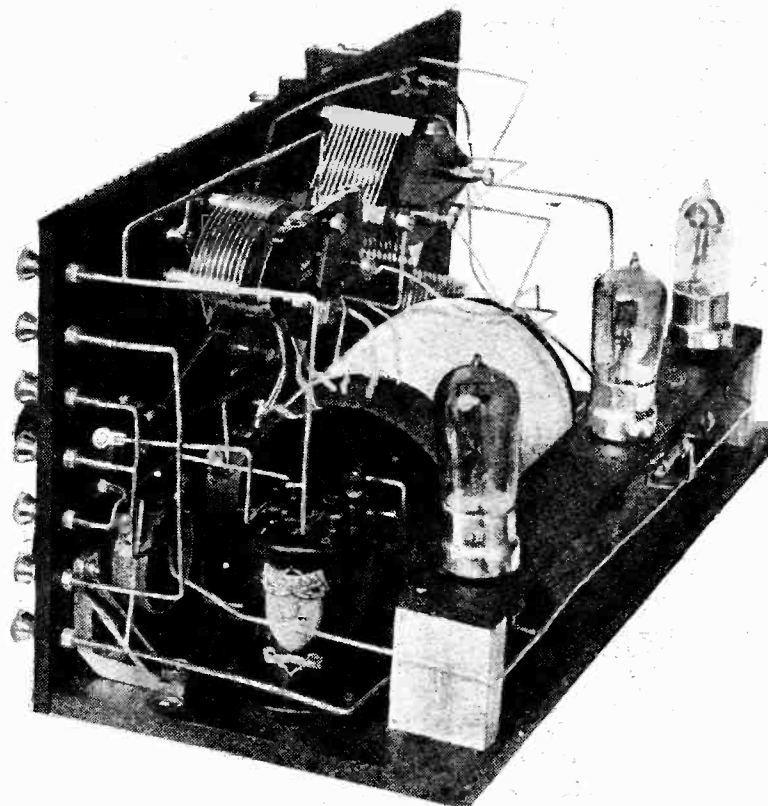

Fig. 6.—Transformer connections are seen to the front of the photograph.

NEW GECOPHONE

WIRELESS COMPONENTS

With Outstanding Characteristics

GECOPHONE

SQUARE LAW VARIABLE CONDENSER A high-class precision instrument.

Low minimum capacity. Ball-bearing movement. Low dielectric losses.

Plates of correct shape giving even tuning over entire scale.

PRICES.

Capacity.	WITHOUT VERNIER.		WITH VERNIER.	
	Cat. No.	Price each.	Cat. No.	Price each.
0002 MFD.	B.C. 200	9/6	B.C. 201	14/6
00025 "	B.C. 202	10/3	B.C. 203	15/3
0003 "	B.C. 204	10/3	B.C. 205	15/3
0005 "	B.C. 206	10/6	B.C. 207	15/6
00075 "	B.C. 208	12/-	B.C. 209	17/-
001 "	B.C. 210	12/6	B.C. 211	17/6

GECOPHONE

PATENT "UNIT" CRYSTAL DETECTOR. The very latest development.

Instant accessibility by lifting small lever, when detector swings open. Universal ball joint self-contained in spring cage. Constant contact. Crystal breech fed from outside of tube.

Cat. No. B.C. 32. For Panel Mounting. Price 2/- each. } Without
 " " B.C. 34. Mounted on base. " 2/6 " } Crystal.

GECOPHONE

MICROMETER CRYSTAL DETECTOR. Cheapest and best of its kind.

Screw-on Crystal Cup.
 Detector arm has free sliding movement for quick contact.
 Micrometer movement for final adjustment.
 Operated from one knob.

Cat. No. B.C. 36. For Panel Mounting. Price 4/- each. } Complete with
 " " B.C. 38. Mounted on base. " 4/6 " } "GECOSITE"
 Crystal.

OBTAINABLE FROM ALL GECOPHONE SERVICE DEPOTS,
 ELECTRICAL AND WIRELESS DEALERS, STORES, ETC.

(Wholesale only) The General Electric Co., Ltd., Head Office, Magnet House, Kingsway, London, W.C.

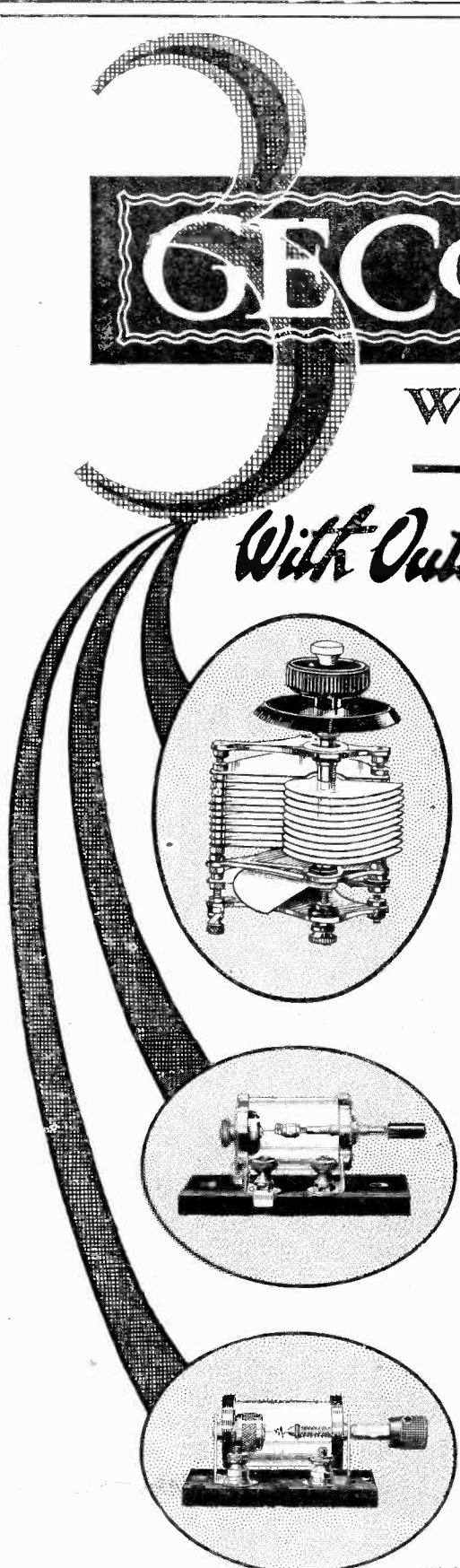

Brandes

The name to know in Radio

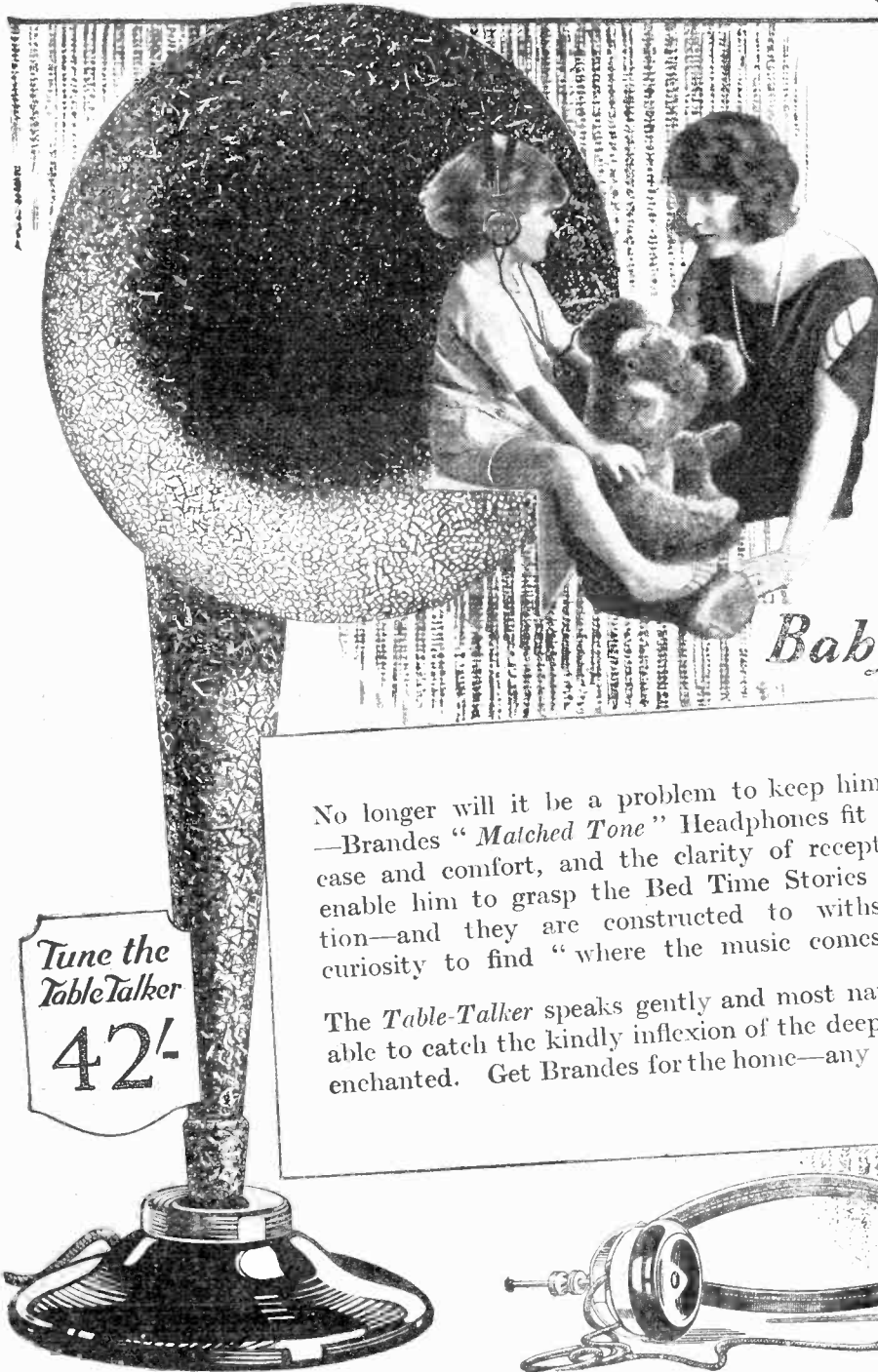

All Brandes products carry our official money-back guarantee, enabling you to return them within 10 days if dissatisfied. This really constitutes a free trial.

Baby's Choice

No longer will it be a problem to keep him contentedly amused—Brandes "Matched Tone" Headphones fit the tender head with ease and comfort, and the clarity of reception they ensure will enable him to grasp the Bed Time Stories with quick appreciation—and they are constructed to withstand his immediate curiosity to find "where the music comes from."

The *Table-Talker* speaks gently and most naturally to him. He is able to catch the kindly inflexion of the deep friendly voices and is enchanted. Get Brandes for the home—any good Dealer has them.

*Tune the
Table-Talker*
42!

*— with the
Matched Tone
Headphones*
25!

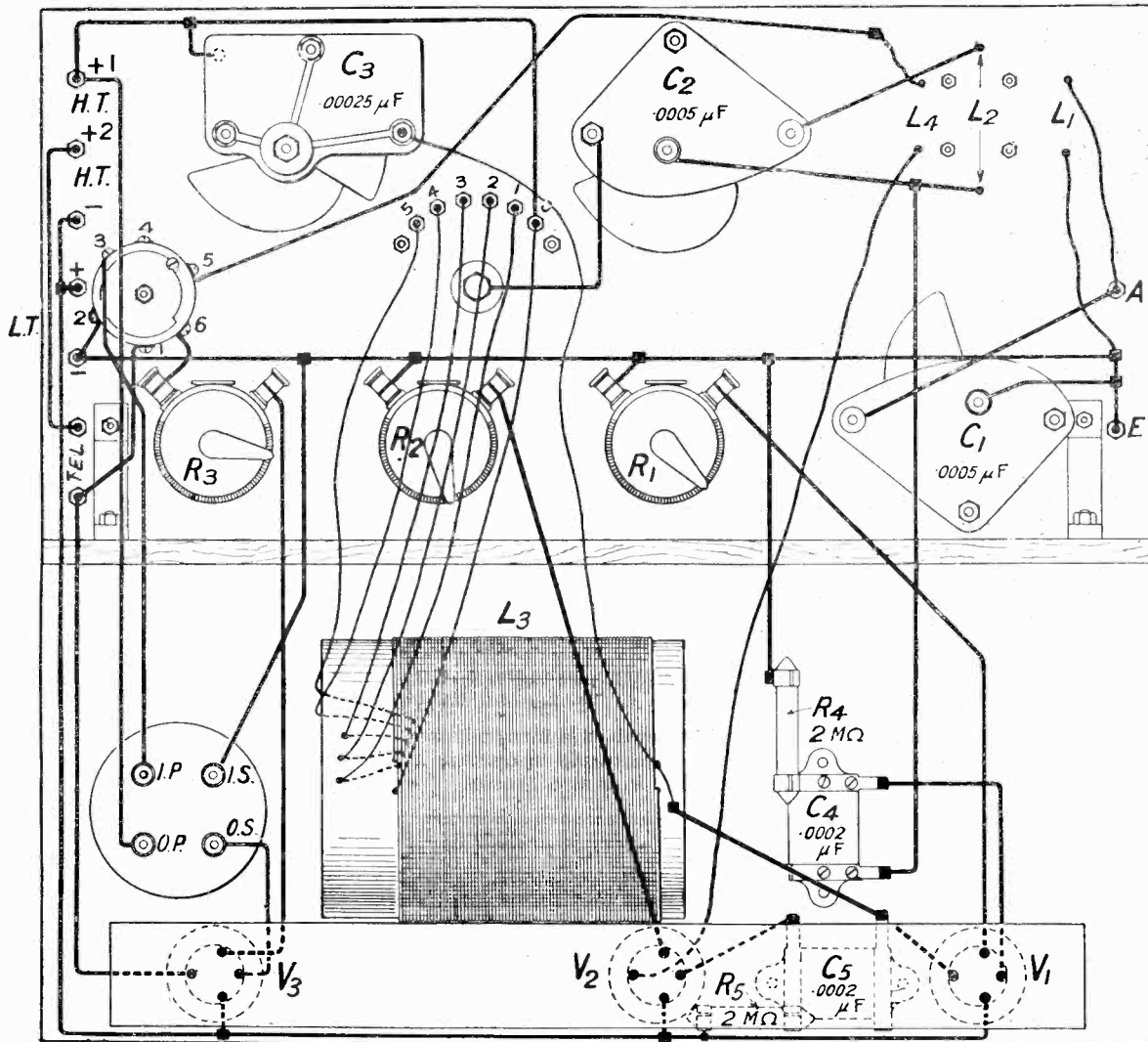

Fig. 7.—If this diagram is followed, no difficulty should be experienced in following the wiring of the set. Blue Print No. 87B.

frequency amplification may be used on the higher wavelengths.

Operating

Testing the receiver is the next operation, and this is carried out as follows: Connect the aerial lead to the top left-hand terminal, and the earth to that immediately beneath it. Telephones to the bottom two terminals in the right-hand row, low-tension negative and positive respectively, are next connected, reading up the row, while the negative high-tension lead is joined next.

The top two terminals are for the positive high-tension supply to the high-frequency and detector and the low-frequency amplifying valves respectively, reading from the top. This completes the external connections, and the valves and coils are next inserted. For average aerials a No. 55 coil will suffice in the aerial circuit for the

lower broadcasting wavelengths, but a No. 50 will be needed in addition if the whole 300-500 metre hand is to be covered. A No. 50 will be required in the fixed socket, while the reaction coil may be a

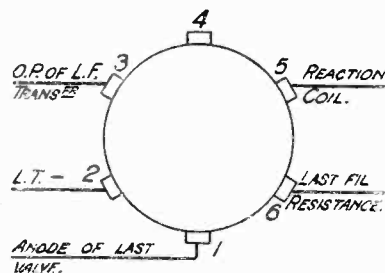

Fig. 8.—Showing the switch connections.

No. 75 or No. 50, according to the ease with which the set will oscillate.

The tuning is accomplished by setting the aerial condenser at

some arbitrary setting, having the aerial coil coupled fairly closely to the grid coil, and the reaction coil swung well away. The selector switch-arm should be over to the right during preliminary trials. The anode and secondary condensers are then simultaneously varied until the desired signal (the local station is best at first) is heard.

Adjust the three condensers to the best positions, and bring up the reaction coil slowly to the fixed (grid) coil. If there is an increase in signal strength, all is well, but if the closest coupling will not produce oscillations, the connections to the reaction coil should be reversed by changing over the flexible leads to the right-hand moving socket.

The best results will be obtained when the aerial coil is loosely coupled to the secondary, as the set is then more selective, and

closer tuning to the desired wave is called for. It may be noticed that in the photographs the .002 μ F condenser across the primary of the low-frequency transformer is missing. This was not in the set at the time the photographs were taken, but will be found an advantage in giving smooth reaction control.

Results Obtained

The set was tried out on a 100 ft. aerial in South-east London, about six miles direct from that station. Signals were all that could be desired, the set operating a loud-speaker with comparative ease. On turning out the filament of the high-frequency valve, signals were reduced in volume to a more marked extent than with the conventional tuned anode circuit.

Unfortunately, one of the now frequent "S.B." nights was accidentally hit upon for the first test, but the carrier of each station, with the exception of Bournemouth and Cardiff, was picked up and resolved, this being a fairly simple matter with square-law condensers. Later on, Madrid and a Continental station, unidentified, were received

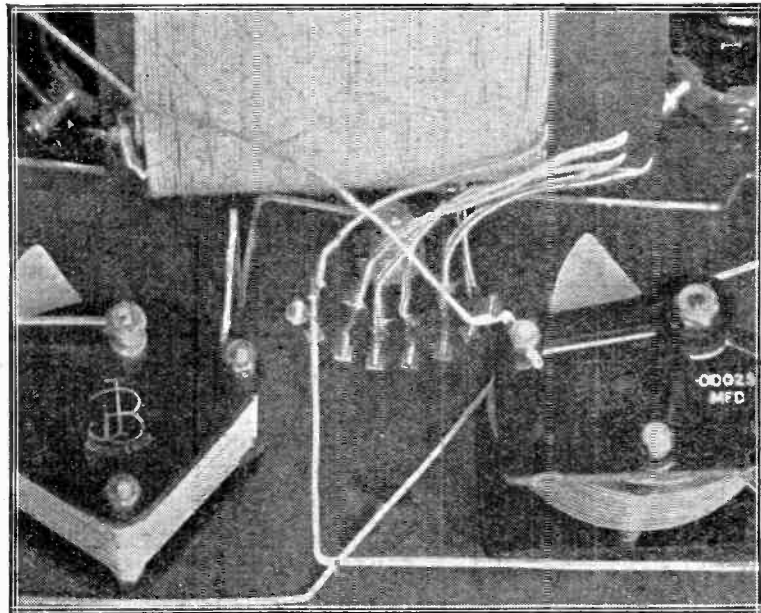
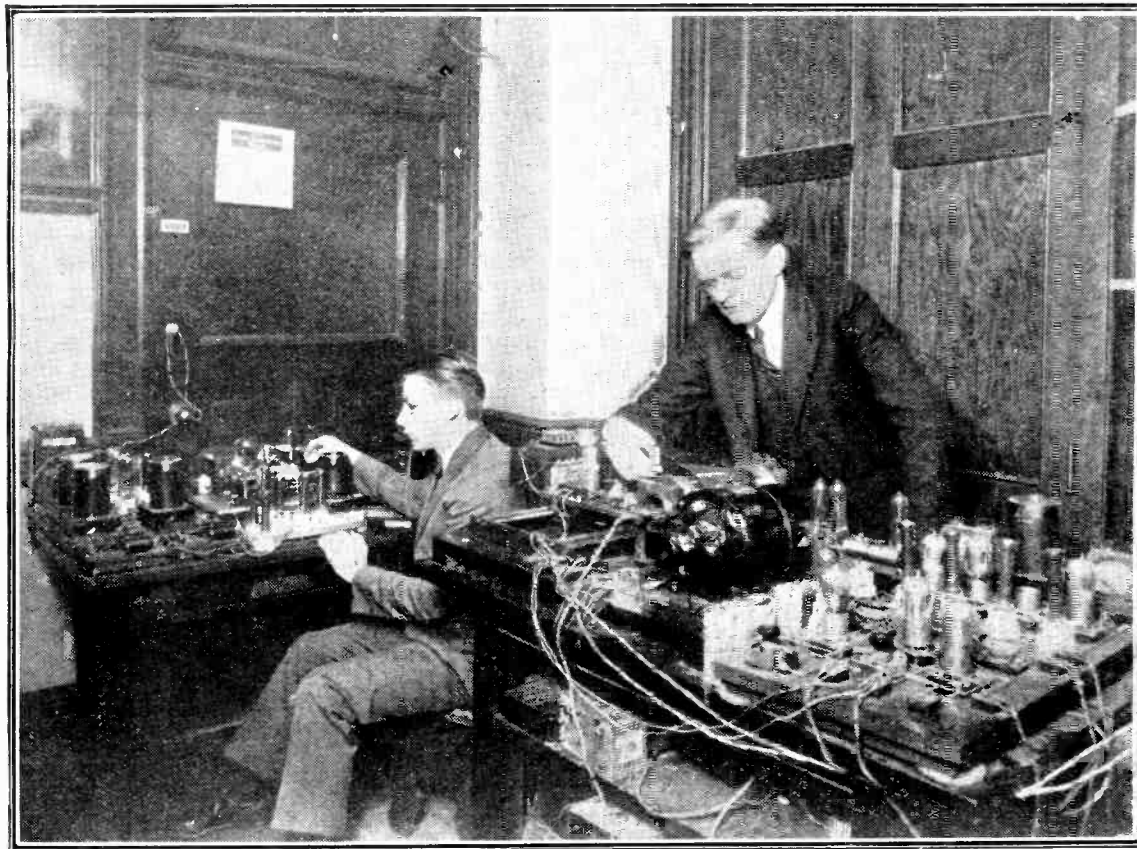

Fig. 9.—This photograph shows the connections to the coil L_3 and its tapping switch.

at good strength, the former being of sufficient strength to operate a loud-speaker in a small room.

On subsequent nights the set brought in all B.B.C. stations easily and regularly.



Photographs were recently transmitted by wireless from London to New York. Our picture shows some of the apparatus used in London.

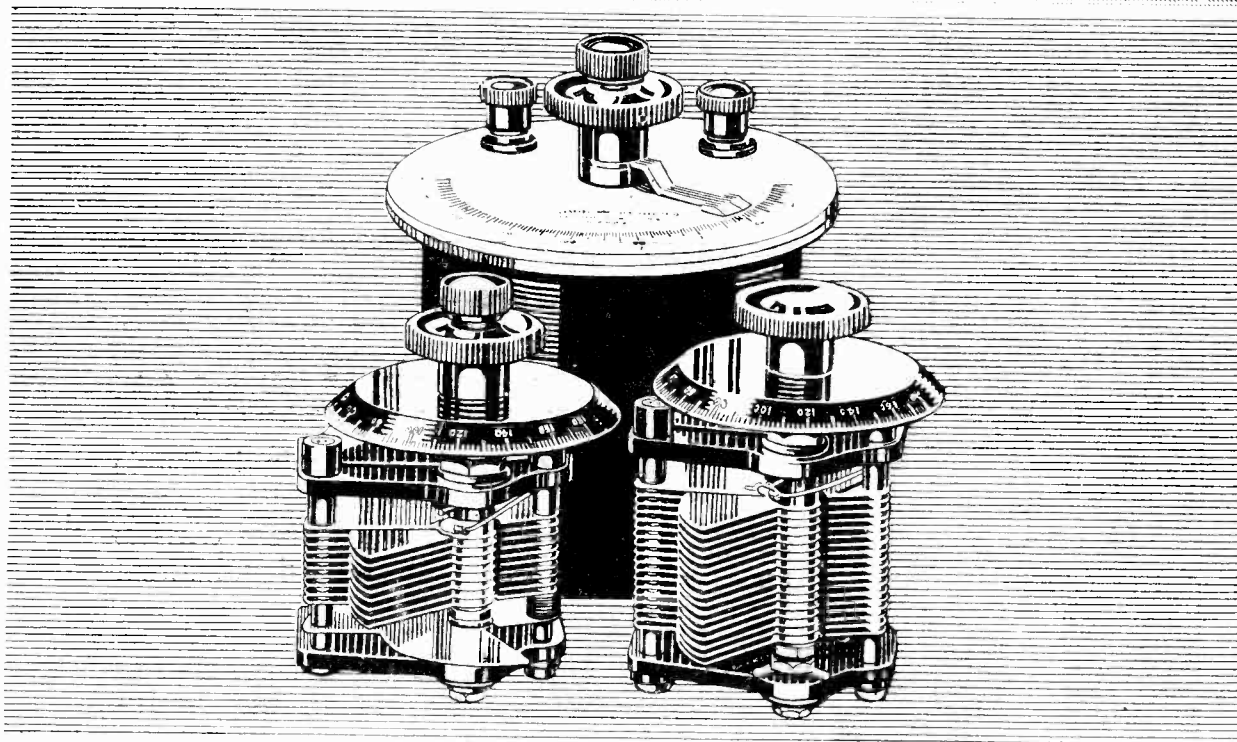

STERLING SQUARE LAW CONDENSERS finish tuning troubles

Owing to the special shape of the vanes in these Condensers the wave-length curve is a straight line, i.e., the wave-length is directly proportional to the number of degrees through which the knob is turned. This gives much greater ease of tuning, a fact readily appreciated by any experimenter.

The end plates are of reinforced insulating material, and the vanes are of brass. Made in three capacities,

either with or without Vernier attachment. A small knob controls the latter independently of the other vanes.

Sterling Square Law Condensers are unrivalled for use in receiving sets and are specially recommended for use in the construction of wave-meters and other radio measuring instruments. Ask your dealer to show you these Condensers — then note the difference and perfect finish.

With Vernier Adjustment

Capacity	For Panel Mounting	In Case with Ivorine Dial
.00025 mfd. ...	R.2724 £1 3 0	R.2733 ... £2 2 6
.0005 mfd. ...	R.2725 £1 5 6	R.2734 ... £2 5 0
.001 mfd. ...	R.2726 £1 10 6	R.2735 ... £2 10 0

Without Vernier Adjustment

Capacity	For Panel Mounting	In Case with Ivorine Dial
.00025 mfd. ...	R.2729 £1 0 0	R.2737 ... £1 19 6
.0005 mfd. ...	R.2730 £1 2 6	R.2738 ... £2 2 0
.001 mfd. ...	R.2731 £1 7 6	R.2739 ... £2 7 0

For Controlling High Frequency Amplification

R.2740	.0002 mfd. (each unit).	For controlling two stages ...	£1 7 6
R.2743	.0002 mfd. (each unit).	For controlling three stages ...	£1 15 0

Your Radio Dealer can supply

Advt. of **STERLING TELEPHONE & ELECTRIC CO., LTD.** Manufacturers of Telephones and Radio Apparatus, etc.
210-212, TOITENHAM COURT ROAD, LONDON, W.1
Works: Dagenham, Essex

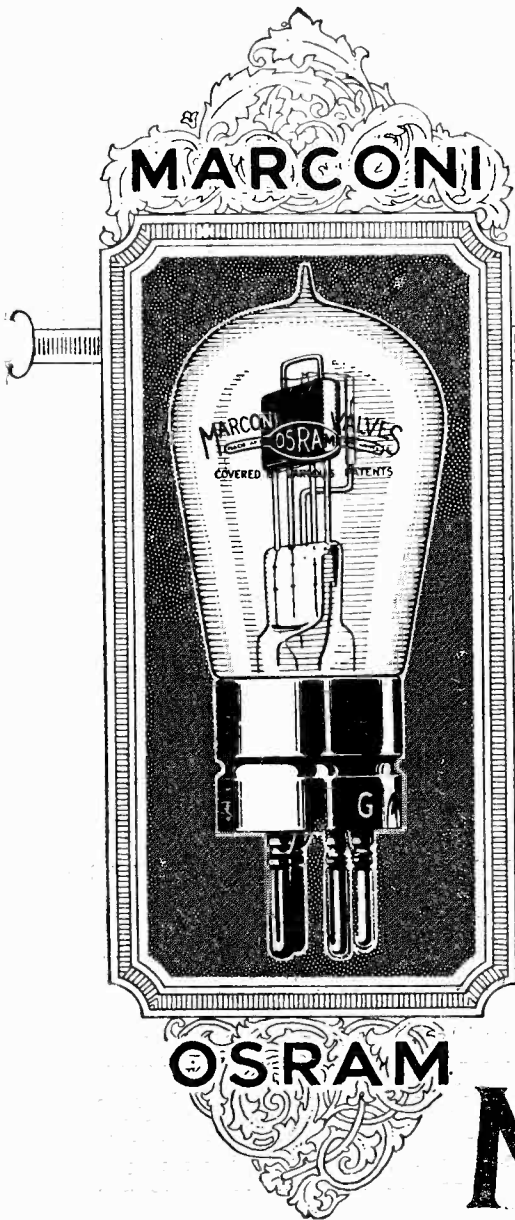

LEADERSHIP

THE design of the Valve in the Purple Box is directed from the leading laboratories in the science of Wireless—those of the great Marconi and Osram organisations.

It is made at the factory with the greatest experience in valve manufacture in the British Empire—the Osram Works.

The characteristics of each type of valve have been decided on as the result of the unrivalled experience of experts, not only in valve design, but also in the design of wireless sets.

MARCONI VALVES

MADE AT THE OSRAM LAMP WORKS

Sold by Wireless and Electrical Dealers, Stores, etc.

Read the authoritative wireless book, *The Book of MOV*. Get a copy from your dealer, or write direct to *The M.O. Valve Co., Ltd., Hammersmith, London, W.6.*

Get the Valve in the Purple Box

ANNOUNCEMENT OF THE M.O. VALVE CO., LTD

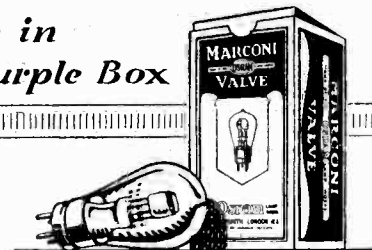

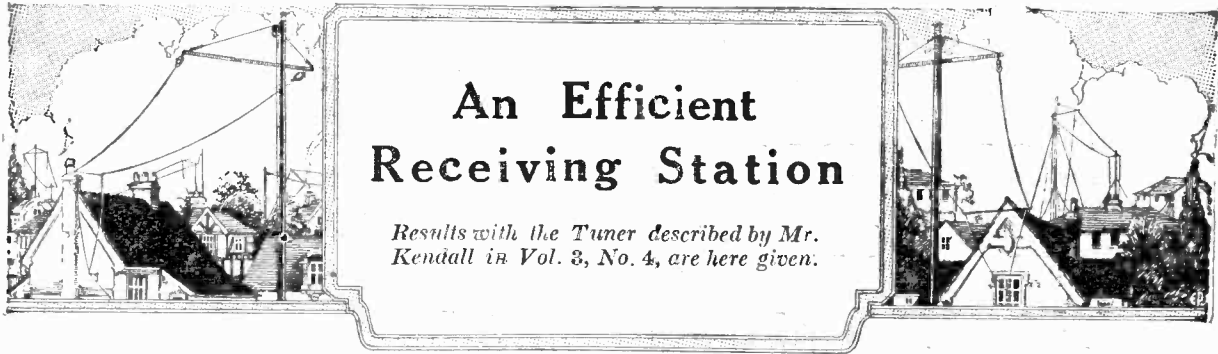

An Efficient Receiving Station

Results with the Tuner described by Mr. Kendall in Vol. 3, No. 4, are here given.

SIR,—I am sending you on a photograph of my wireless receiving station. Although the receiver is not of a design that has appeared in MODERN WIRELESS or *Wireless Weekly*, several features contained in the set have been copied from your publications, most noticeably the experimental tuner by Mr. Kendall, for with this tuner I am able to completely eliminate our local station, 5PY, a quarter of a mile or so distant.

The amplifier is a five-valve set, all B.T.H. valves being used, 2 H.F.

crystal or leaky grid rectification, 2 L.F.

The best class of material was used throughout in building up this apparatus, and it has amply repaid me by results that I am able to get, for I can receive all stations easily on three valves and at quite good strength, whilst on numerous occasions I have received several American stations just after midnight.

To my mind Mr. Kendall's tuner is absolutely the best for the serious amateur.

The various instruments on the

switchboard are all of the moving coil measuring type, and are always in circuit with any number of valves.

On the table in front of the Brown L.S. is a single valve reflex set, and is a little gem of a set, for I can get most stations easily with my P.O. aerial.

The equipment also contains a Morse recording apparatus.

Trusting these few remarks may interest readers of your publications, and wishing your periodicals success.—Yours truly,
Plymouth. S. W. HEATH.

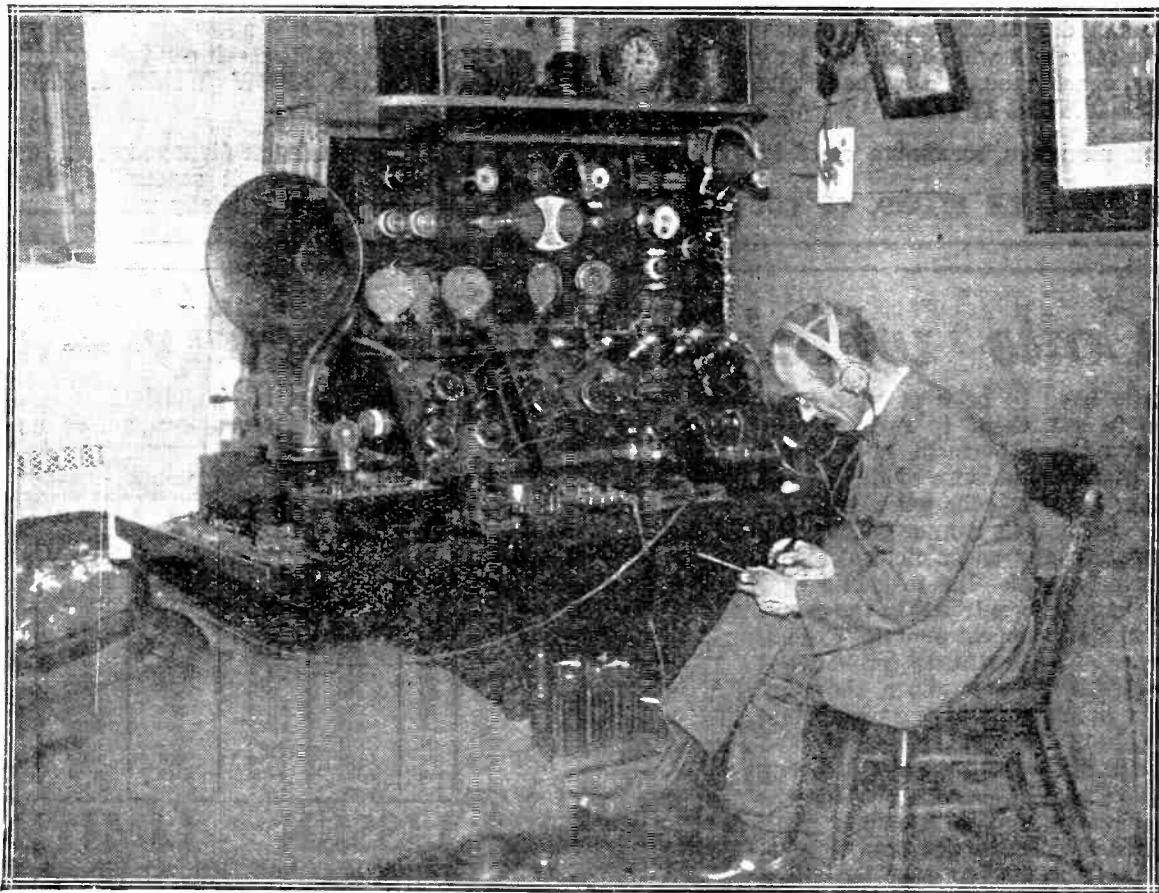

Mr. Heath is here seen with his station described above.

LISSENIUM

The Condenser and the Coil—

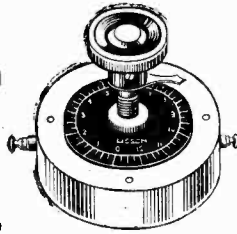

This new LISSEN Mark 2 MICA VARIABLE CONDENSER and LISSENAGON (pronounced LISSEN=AGON) Coils.

two LISSEN things which together make the finest tuning combination there is.

THE LISSEN CONDENSER, with its open scale and delightful tuning characteristics—the condenser which it is safe to prophesy will achieve a great use because it fills a great need.

On short wave work, where tuning is so critical, its open scale results in small changes of capacity for a given movement of the pointer. On long wave work you have immediately available with the same knob control the great advantage of being able to put a comparatively high capacity (the condenser is conservatively rated at .001 maximum) across the inductance without any H.F. losses through the extra shunted capacity. The inductance is thus made to cover an extremely wide range without any decrease of signal strength.

With ordinary condensers every receiver really needs two condensers—one for short wave work, and one of high capacity for long wave work. This LISSEN condenser performs the functions of both such condensers, and with greater efficiency and convenience. Its open scale and perfect capacity curve make tuning delightfully easy—it tunes along a straight line wave-length curve—it is a low loss condenser—it is dustproof—it will be noiseless for ever—it is immune from stray capacity effect—it can be used for table or panel mounting without alteration—**BUY IT, AND YOU WILL KNOW WHAT A PERFECT CONDENSER IS LIKE.**

Negligible minimum, maximum rated at .001.

LISSEN ONE HOLE FIXING, OF COURSE.

17/6

This LISSEN Condenser gives you every capacity you will ever need—it supersedes all other Condensers—and it is totally unlike them.

Coils which oscillate easily—

Some coils have to be kept right close together to get them to oscillate. In that case every movement of one coil detunes the other because of the mutual interaction between coils when they are so close. Some coils cannot be kept far apart because the magnetic linkage is comparatively weak—the magnetic field may be closely concentrated in the centre of the coil, and the field may not extend. In the case of LISSENAGON (pronounced LISSEN-AGON) coils, however, the magnetic field, in addition to being very strong in the centre of the field, is also distributed on each side of the coil—the field is strong along the edges. This accounts for the strong magnetic linkage obtained with LISSENAGON coils in reaction circuits, so that the coils can be kept far apart. LISSENAGON COILS ARE COILS WITH PECULIAR EFFICIENCY.

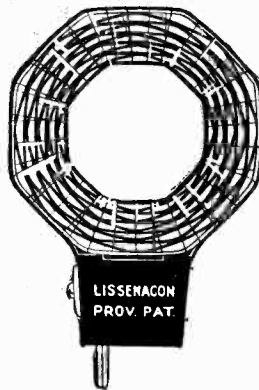

IF YOU EVER WANT COILS WHICH INTENSIFY TUNING—USE LISSENAGON COILS.

LISSENAGON TUNING CHART.

Note the Intermediate coils, 30, 40 and 60.

No. of Coil.	TABLE I. Wave-length range when used as Primary Coils with Standard P.M.G. Aerial and .001 mfd. condenser in parallel.		TABLE II. Wave-length range when used as Secondary Coils with .001 mfd. condenser in parallel.		PRICE.
	Minimum Wave-length.	Maximum Wave-length.	Minimum Wave-length.	Maximum Wave-length.	
25	185	350	100	325	4/10
30	235	440	130	425	4/10
35	285	530	160	490	4/10
40	360	675	200	635	4/10
50	480	850	250	800	5/-
60	500	950	255	900	5/4
75	600	1,300	360	1,100	5/4
100	820	1,700	500	1,550	6/6
150	965	2,300	700	2,150	7/7
200	1,885	3,200	925	3,000	8/5
250	2,300	3,800	1,100	3,600	8/9
300	2,500	4,600	1,400	4,300	9/2

LISSEN LIMITED,
20-24, Woodger Rd., Goldhawk Rd.,
LONDON, W.12.

DON'T MIX YOUR PARTS—there is a LISSEN Part for every vital place.

LISSENIUM.

Put a fine edge on your tuning—

The advantages of LISSENSTAT control are so great that those who want fine detection and know how to get it will have nothing else but LISSENSTAT control for the filament current of the valve. Not only does it keep valves quiet, pass a steady, unvarying current, remain noiseless from the first turn to the last, but by its critical control of electronic flow it gives the valve a capacity to detect as no other rheostat can. LISSENSTAT control adds range to a receiver because you can feel for the point of critical detection and unerringly find it.

Sold in three models :—

- LISSENSTAT MINOR (patents pending) is replacing many thousands of inefficient rheostats—provides LISSENSTAT control at a popular price **3/6**
- LISSENSTAT MAJOR (patents pending) gives the most acute tuning possible **7/6**
- LISSENSTAT UNIVERSAL (patents pending)—with its protective device for dull emitters **10/6**

Minute Grid Currents

The leak which gives you the necessary control over the minute currents flowing in the grid of your valve is the LISSEN Variable Grid Leak (patents pending). See that you get the one with the nickel fittings. This is the latest type, and it represents a very high degree of efficiency in the control of grid potential. Its fitting in a receiver is very necessary if the operator is keen on getting that extra sensitivity which results in clear, strong signals when otherwise they would be weak and obscure. Every resistance value required of a leak is covered. LISSEN ONE-HOLE FIXING, OF COURSE **2/6**

LISSEN Variable Anode Resistance, 20,000 to 250,000 ohms, same outward appearance as the LISSEN Variable Grid Leak **2/6**

Parts which pull together—

when you know that every part in your receiver is pulling strongly with each other, you know you have a receiver which is the best you can ever get.

BUILD—WITH YOUR OWN HANDS—WITH ALL LISSEN PARTS.

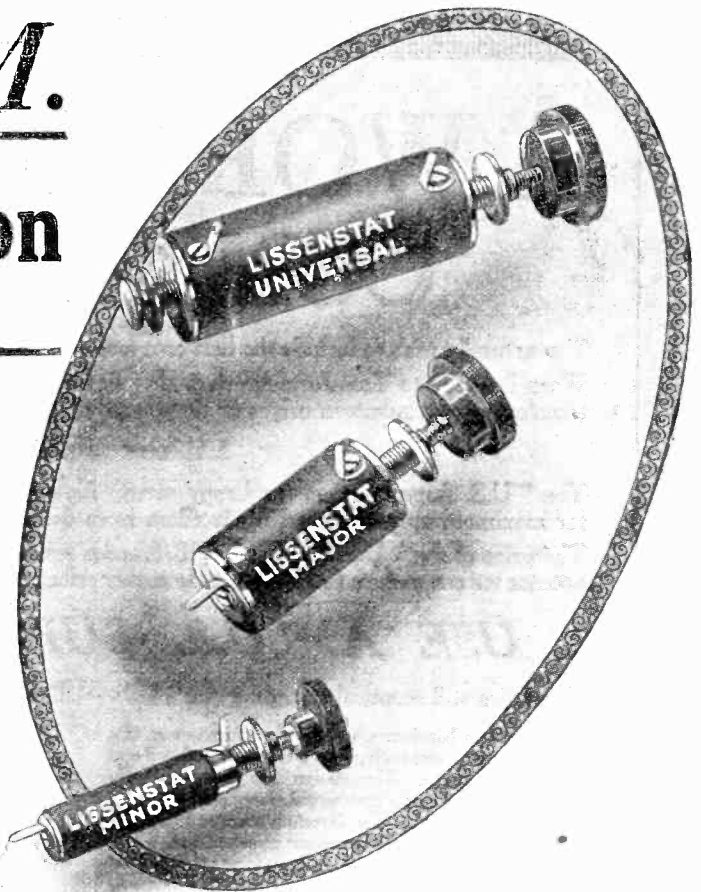

TO THOSE WHO THINK LISSENSTAT CONTROL IS THE SAME THING AS AN ORDINARY RHEOSTAT—LET THEM TRY THE DIFFERENCE



SMOOTH OUT YOUR LOUD-SPEAKER DISTORTION BY PUTTING THE LISSEN VARIABLE GRID LEAK ACROSS THE SECONDARY OF THE LAST TRANSFORMER, OR ACROSS THE LOUD-SPEAKER ITSELF—first position is the better.

BUILD—WITH ALL LISSEN PARTS—there is one for every vital place.

LISSEN LIMITED,
20-24, Woodger Rd., Goldhawk Rd., London, W.12

Telephones : Riverside 3380, 3381, 3382, 1072.
Telegrams : "Lissenium, London."

A WORD TO EVERY CONSTRUCTOR!

You naturally wish to include the best components in your sets, and to ensure this you probably pay high prices. When it comes to Transformers—how do you buy? Do you follow a policy of false economy and buy cheap transformers of unknown origin or do you go to the other extreme and pay a fancy price for a fancy name?

Either Policy is Wrong.

The "U.S. Super" offers the happy mean. No Transformer yet on the market can excel the "U.S. SUPER" for maximum amplification with freedom from distortion.

The price of the "U.S. SUPER" is 18/6, and is equal in design, finish and performance to any. We charge 18/6 because we can make a first-class article at this price. Compared with others, the "SUPER" is worth double.

USE A "U.S. SUPER" AND BE SAFE

If you are still sceptical regarding the "U.S. SUPER" read what the unbiased Wireless Press says of it:—

"This is a handsome, well-finished instrument of a familiar type superficially, with a large vertical coil and ample core room. The design has been carefully thought out, and really comfortably large and accessible terminals are fitted. The favourable impression given by a first inspection was borne out in actual test. The build-up recorded with this Transformer compared very favourably with that obtained with other standard patterns under identical conditions, whilst the tone was comparable to the best of the others. The present instrument can be heartily recommended, and indicates the vast strides that have been made recently in the design of L.F. Transformers."

Modern Wireless.

November, 1924.



SUPER TRANSFORMER

Wholesale only:

**U.S. Radio Co., Ltd., 155, High St.,
Lewisham, S.E.13.**

'Phone: Lee Green 2404. 'Grams: "Supertran, Lewis, London."

"Mechanical construction very strong. The iron circuit is of 'Stalloy' and is tested up to 500 volts between windings. Ratio is 5:1.

"Under test the Transformer gave every satisfaction. It was tested in three positions before first and second stages of amplification and before power stage. Ample volume and good tone were secured and there was no trace of distortion. We found the transformer quite suitable in front of an L.S.3 power valve. Highly recommended."

Broadcaster and Wireless Retailer.

September, 1924.

Maximum Magnification without Distortion —the Secrets here—

All-British made throughout, the U.S. Transformer's success lies in the excellence of its design. The core, with no bolts through it, is packed with finest Stalloy iron, allowing fullest amplification without hint of distortion; winding is done by experts; terminals are large and comfortable, with ebonite strips at top and soldering tags. Ratio guaranteed 5:1. Remember—it's British.

Two other U.S. Transformers are also made:

No. 1, suitable for first stage work. Price 14/6

No. 2, designed for following stages, and power work. Price 11/6

All U.S. L.F. Transformers are tested and guaranteed.

PRICE

18/6

EACH.

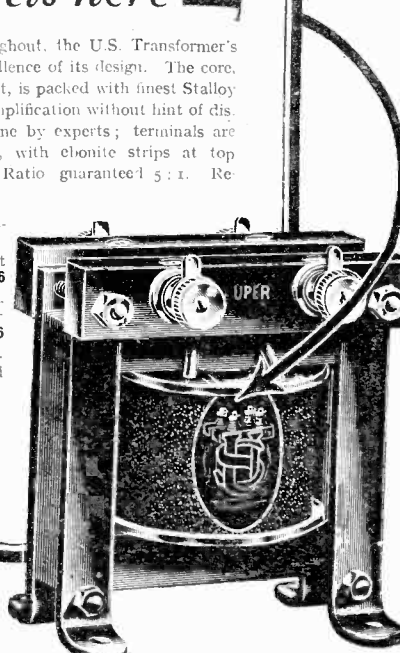

Regular Programmes from American Broadcasting Stations

Telephony only. Corrected up to December 10th.

Edited by Captain L. F. PLUGGE, B.Sc., F.R.Ae.S., F.R.Met.S. Copyright.

WEEKDAYS.

Ref. No.	Greenwich Mean Time.	Local Time prevailing.	Name of Company owning Station.	Call Sign and Wave-length.	Situation.	Nature of Transmission.	Approx. duration of Transmission.
A. 1	11. 0 p.m.	6. 0 p.m.	Willard Storage Battery Co.	WTAM 390 m.	Cleveland, Ohio.	Dance Music, Concert, Orchestra.	1 hr.
A. 2	11. 0 p.m.	6. 0 p.m.	Westinghouse Electric & Mfg. Co.	WBZ 337 m.	Springfield, Mass.	Dinner Concert.	—
A. 3	11.15 p.m.	6.15 p.m.	L. Bamberger & Co.	WOR 405 m.	Newark, New Jersey.	Orchestra.	—
A. 4	11.30 p.m.	6.30 p.m.	Westinghouse Electric & Mfg. Co.	KDKA 326 m.	Pittsburg.	Dinner Concert or Organ Recital.	—
A. 5	11.50 p.m.	5.50 p.m.	"Kansas City Star"	WDAF 411 m.	Kansas City, Mo.	Market, Weather Report, Time Signal, Road Report.	10. 0 p.m.
A. 6	midnight	6. 0 p.m.	"Kansas City Star"	WDAF 411 m.	Kansas City, Mo.	Talks, Story, Music.	1 hr.
A. 7	midnight	7. 0 p.m.	Westinghouse Electric & Mfg. Co.	WBZ 337 m.	Springfield, Mass.	Market Report, Talks, Children's Stories.	15 min.
A. 8	12. 2 a.m.	6. 2 p.m.	Westinghouse Electric & Mfg. Co.	KYW 536 m.	Chicago, Ill.	News, Financial Markets.	16 min.
A. 9	12.15 a.m.	7.15 p.m.	L. Bamberger & Co.	WOR 405 m.	Newark, New Jersey.	Sports News.	—
A. 10	12.15 a.m.	7.15 p.m.	Westinghouse Electric & Mfg. Co.	KDKA 326 m.	Pittsburgh, Pa.	Children's Period.	—
A. 11	12.15 a.m.	7.15 p.m.	Westinghouse Electric & Mfg. Co.	WBZ 337 m.	Springfield, Mass.	Talks followed by Concert or other Musical Programme.	—
A. 12	12.30 a.m.	6.30 p.m.	Woodmen of the World.	WOAW 526 m.	Omaha, Nebraska.	Concert or Orchestra.	—
A. 13	12.30 a.m.	7.30 p.m.	Westinghouse Electric & Mfg. Co.	KDKA 326 m.	Pittsburgh, Pa.	News, Talks, Market Reports, Talks or Concert.	45 min.
A. 14	12.35 a.m.	6.35 p.m.	Westinghouse Electric & Mfg. Co.	KYW 536 m.	Chicago, Ill.	Children's Period.	25 min.
A. 15	12.45 a.m.	7.45 p.m.	General Electric Co.	WGY 380 m.	Schenectady, New York	Musical Programme and/or talks (except Wed. and Sat.).	—
A. 16	1. 0 a.m.	7. 0 p.m.	Westinghouse Electric & Mfg. Co.	KYW 536 m.	Chicago, Ill.	Talks, Dinners, Concerts, Musical Programmes (Mondays excepted).	2½ hrs.
A. 17	1. 0 a.m.	7. 0 p.m.	Sears-Roebuck & Co.	WLS 345 m.	Chicago, Ill.	Children's Period.	45 min.
A. 18	1.30 a.m.	8.30 p.m.	Westinghouse Electric & Mfg. Co.	KDKA 326 m.	Pittsburgh, Pa.	Concert and Musical Programme.	—
A. 19	1.30 a.m.	7.30 p.m.	"Fort Worth Star Telegram."	WBAP 476 m.	Fort Worth, Texas.	Musical Programme (except Saturday).	1 hr.
A. 20	2.0 a.m.	8.0 p.m.	"Kansas City Star."	WDAF 411 m.	Kansas City, Mo.	Musical Programme.	1½ hrs.

WEEKDAYS—continued.

Ref. No.	Greenwich Mean Time.	Local Time prevailing.	Name of Company owning Station.	Call Sign and Wave-length.	Situation.	Nature of Transmission.	Approx. duration of Transmission.
A. 21	2.55 a.m.	9.55 p.m.	John Wanamaker	WOO 509 m.	Philadelphia, Pa.	U.S. Naval Observatory Time Signal followed by U.S. Weather forecast.	—
A. 22	2.55 a.m.	9.55 p.m.	Westinghouse Electric & Mfg. Co.	KDKA 326 m.	Pittsburg, Pa.	Do. do.	—
A. 23	2.55 a.m.	9.55 p.m.	Westinghouse Electric & Mfg. Co.	WBZ 337 m.	Springfield, Mass.	Do. do.	—
A. 24	3. 0 a.m.	9. 0 p.m.	Woodmen of the World.	WOAW 526 m.	Omaha, Nebraska.	Concert (except Wednesdays).	—
A. 25	3. 0 a.m.	10. 0 p.m.	Westinghouse Electric & Mfg. Co.	WBZ 337 m.	Springfield, Mass.	Musical Programme (except Tuesdays)	1 hr. or 2 hrs.
A. 26	3.15 a.m.	7.15 p.m.	"Morning Oregonian."	KGW 492 m.	Portland, Oregon.	Markets, Weather Report, News, Police Reports (Saturdays excepted)	—
A. 27	3.30 a.m.	9.30 p.m.	"Fort Worth Star Telegram."	WBAP 476 m.	Fort Worth, Texas.	Musical Programme (except Saturday).	1 1/4 hr.
A. 28	4. 0 a.m.	10. 0 p.m.	Westinghouse Electric & Mfg. Co.	KYW 536 m.	Chicago, Ill.	Musical Entertainment (except Mondays). Sometimes begins 9.30 p.m.	1 hr. or 2 hrs.
A. 29	5.45 a.m.	11.45 p.m.	"Kansas City Star"	WDAF 411 m.	Kansas City, Mo.	Musical Entertainment.	1 1/4 hr.

SUNDAYS.

Ref. No.	Greenwich Mean Time.	Local Time prevailing.	Name of Company owning Station.	Call Sign and Wave-length.	Situation.	Nature of Transmission.	Approx. Duration of Transmission.
A. 30	11.30 p.m.	6.30 p.m.	Westinghouse Electric & Mfg. Co.	KDKA 326 m.	Pittsburg, Pa.	Dinner Concert	—
A. 31	midnight.	6. 0 p.m.	Woodmen of the World.	WOAW 526 m.	Omaha, Nebraska.	Bible Study Hour	1 hr.
A. 32	12.30 a.m.	7.30 p.m.	Strawbridge and Clothier.	WFI 395 m.	Philadelphia, Pa.	Church Service	—
A. 33	12.30 a.m.	7.30 p.m.	General Electric Co.	WGY 380 m.	Schenectady, New York.	Church Service	—
A. 34	12.30 a.m.	7.30 p.m.	Westinghouse Electric & Mfg. Co.	KDKA 326 m.	Pittsburgh, Pa.	Church Service	—
A. 35	12.45 a.m.	7.45 p.m.	John Wanamaker	WOO 509 m.	Philadelphia, Pa.	Church Service (occasionally at 10.45 p.m. instead).	—
A. 36	1. 0 a.m.	7. 0 p.m.	Westinghouse Electric & Mfg. Co.	KYW 536 m.	Chicago, Ill.	Service & Musical programme.	—
A. 37	1.30 a.m.	8.30 p.m.	Westinghouse Electric & Mfg. Co.	WBZ 337 m.	Springfield, Mass.	Concert or Music, etc.	—
A. 38	2. 0 a.m.	6. 0 p.m.	"Morning Oregonian."	KGW 492 m.	Portland, Oregon	Church Service	—
A. 39	2. 0 a.m.	9. 0 p.m.	General Electric Co.	WGY 380 m.	Schenectady, New York.	Hotel Orchestra, relayed.	—
A. 40	2.30 a.m.	9.30 p.m.	Westinghouse Electric & Mfg. Co.	WBZ 337 m.	Springfield, Mass.	Concert or Music, etc.	—
A. 41	3. 0 a.m.	7. 0 p.m.	"Morning Oregonian."	KGW 492 m.	Portland, Oregon.	Hotel Orchestra, relayed.	—
A. 42	3. 0 a.m.	9. 0 p.m.	Woodmen of the World.	WOAW 526 m.	Omaha, Nebraska.	Church Service	—
A. 43	7. 0 a.m.	11. 0 p.m.	"Fort Worth Star Telegram."	WBAP 476 m.	"Fort Worth, Texas."	Dance Orchestra	1 hr.

ELECTRON WIRE

THE PERFECT AERIAL

DOES BROADCASTING OWE ITS POPULARITY TO ELECTRON WIRE?

YES! VERY LARGELY BECAUSE ELECTRON WIRE SOLVED THE AERIAL PROBLEM.

IT BROUGHT WIRELESS WITHIN THE REACH OF ALL

Until the advent of "Electron Wire," thousands of people were unable to install a simple crystal set because of the aerial difficulties. They had heard so much about the efficiency of a set depending upon the aerial that they really imagined it absolutely necessary to fit up an elaborate affair with masts, stays, insulators, lead-in tubes and also to make holes in the walls or windows, etc., an expensive item generally. Many landlords of flats positively refuse to allow such an aerial. Then we offered "ELECTRON WIRE," and instantly masts, insulators, lead-in tubes, and costly bills were absolutely abolished, and everybody can fix an efficient aerial indoors or out of doors for the total outlay of 1s. 8d. for 100 ft., sufficient for Complete Aerial, Lead-in, and Earth.

ABOUT OURSELVES.—Manufacturers and Wireless Dealers throughout the world should consider what we have done for them and will continue to do. Although "ELECTRON WIRE" is cheap and MAY mean the loss of an order for an elaborate and more profitable aerial because of its simplicity and inexpensiveness, "Electron Wire" has created a demand for hundreds of thousands of receiving sets which otherwise would not have been bought—and it is a well-known fact that once a wireless enthusiast installs his first set, he is a permanent enthusiast, striving for better and better reception and therefore a permanent customer.

The Aerial you will eventually use. But be sure it is Electron Wire in our distinctive boxes only (see illustration—printed in blue).

PUBLIC WARNING.

Buy Electron Wire in BOXES ONLY. Take no substitute. Some dealers try to deceive you. They make coils to look like Electron. They know that the way to sell you another wire is to make it seem like Electron. Buy Electron Wire in our distinctive BOXES ONLY. AVOID DECEPTION. Don't buy another wire made to look or sound like Electron. LOOK AT THE NAME AND THE BOX.

The **CHEAPEST AERIAL** **1/8**
and the Best in the World.

Also laid double for extending 'Phones, Loud Speakers, etc. }
 Two 150 feet lengths twisted. 300 ft. **5/-**
 Two 250 feet lengths twisted. 500 ft. **8/-**
 Two 500 feet lengths twisted. 1,000 ft. **15/-**
 Carriage Paid.

New London Electron Works

(Members of the B.B.C.) LIMITED

99, REGENT'S DOCK, LONDON, E.14.

Telephones: EAST 1821; EAST 6043.

Telegrams: "STANNUM, LONDON."

BUSES Nos. 13, 23, 40. 1d. from Aldgate. (Nr. East Stepney Stn., L.N.E.R.)

DO IT AT HOME

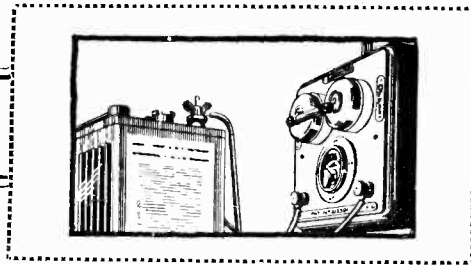

Charge your own Accumulators

An ingenious yet simple device which is interposed in your house lighting or heating circuit by a single connection, enables Batteries to be charged without an atom of cost. The "Ulinkin" House Battery Charger operates whenever lamps, heaters, electric iron, or vacuum cleaner are in use. It is automatic, requires no attention, has no moving or wearing parts, and cannot go wrong.

List No. RA52/5.

Each £2 2s. 0d.

Please order from your wireless dealer.

Brown Brothers

Allied Companies: Thomson & Brown Brothers, Ltd., Brown Brothers (Ireland), Ltd.

Wholesale only: GREAT EASTERN ST., LONDON, E.C. 2. Head Offices and Warehouses: 118, George St., Edinburgh, and Branches.

LOOK TO YOUR TUNERS

for dielectric losses

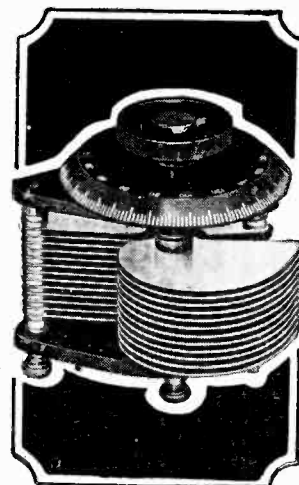

Whether your present condensers are Metal or Ebonite End Plates and your receiver unaccountably lacking power — be sure your trouble lies in the bad insulating properties of the insulation between the two sets of plates. High dielectric losses cause leakages, absorptions, inability to oscillate on the lower degrees of the scale. These signal-weakening losses follow the use of poor quality End Plates or insulating bushes. Your only safeguard against condensers in this category is simplicity itself. Always purchase Condensers bearing our monogram — it is the insignia of low dielectric loss — actually J.B. are recorded (N.P.L.) 0.05 ohms — a negligible quantity.

Incorporation of J.B. Condensers gives you the highest tuner efficiency. Fit them — preferably the J.B. Square Law.

001	9 6	00025	6 9
00075	9/-	0002	5 6
0005	8/-	0001	5 3
0003	6 9	Verrier	4 6

As Condenser Manufacturers we have long realised the vital electrical duty of variable condensers. J.B. Condensers represent both high mechanical and electrical design.

J.B. Instruments are obtainable from all dealers or direct from the manufacturers: Post, one, 6d.; two, 9d.; three, 1s.

JACKSON BROS.
B. POLAND ST- OXFORD ST
LONDON - W.1.
Telephone: GERRARD 7414.
(First Floor)

Barclays 400

A NEW AND GREAT EXCELLENCE IN POWER AND QUALITY

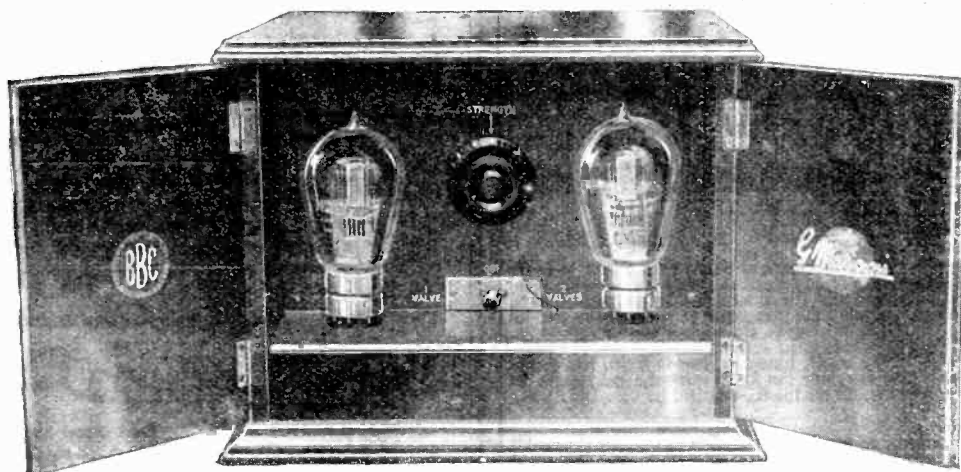

The Marconiphone Two-Valve Power Amplifier

THE power of this amplifier is remarkable in itself; the entire absence of distortion, no matter what the degree of volume produced, is the outstanding achievement.

This achievement is largely due to the incorporation of Marconiphone "Ideal" Transformers (in ratios of 2.7 to 1 and 8 to 1) in conjunction with L.S.5 power valves.

Superlatively good in quality and performance, this amplifier is as practical in its uses. The controls are so arranged that either one or two valves may be used, allowing the volume to be adjusted to suit the small room or the large hall. A powerful receiver is not essential.

Price, entirely complete with two L.S.5 valves, batteries, etc., £27 12s.

Write for full particulars and name of dealer to
THE MARCONIPHONE COMPANY, LTD.,
Marconi House, Strand, London, W.C.2.

Marconiphone

BROADCAST
RECEIVING APPARATUS



THE WORLD'S STANDARD FOR ACHIEVEMENT IN RADIO

SPECIAL DAYS.

Ref. No.	Greenwich Mean Time.	Local Time prevailing.	Name of Company owning station.	Call Sign and Wave-length.	Situation.	Nature of Transmission and day of week on which occurring.	Approx. duration of Trans-mission.
A. 44	11.30 p.m.	6.30 p.m.	General Electric Co.	WGY 380 m.	Schenectady, New York.	Tues. & Thurs.— Hotel Music re- layed.	—
A. 45	11.30 p.m.	6.30 p.m.	Strawbridge and Clothier.	WFI 395 m.	Philadelphia, Pa.	Wed.—Children's story. Mon. & Sat.— Hotel Concert Orchestra fol- lowed by Chil- dren's period at 7.0 p.m.	—
A. 46	midnight	6.0 p.m.	Woodmen of the World.	WOAW 526 m.	Omaha, Nebraska. Pa.	Mon. & Tues.— Lecture. Thurs. & Fri.— Children's Hour. Sat.—Concert.	—
A. 47	12.30 a.m.	7.30 p.m.	John Wanamaker.	WOO 509 m.	Philadelphia, Pa.	Mon., Wed., Fri.— Organ or Orches- tral Concerts, Talks.	3½ hrs.
A. 48	1.0 a.m.	8.0 p.m.	Strawbridge and Clothier.	WFI 395 m.	Philadelphia, Pa.	Thurs.—Boy Scout Programme, fol- lowed by Con- cert at 8.30 p.m.	2½ hrs.
A. 49	1.0 a.m.	8.0 p.m.	L. Bamberger & Co	WOR 405 m.	Newark, New Jersey.	Tues. and Sat.— Concert. Mon., Wed., Sat.— Musical Pro- gramme, Talks.	2½ hrs. 3 or 4 hrs.
A. 50	1.0 a.m.	8.0 p.m.	Willard Storage Battery Co.	WTAM 390 m.	Cleveland, Ohio.	Mon. & Wed.— Concert.	2 hrs.
A. 51	2.0 a.m.	9.0 p.m.	Willard Storage Battery Co.	WTAM 390 m. or 361 m.	Cleveland, Ohio.	Sat.—Dance Pro- gramme.	3 hrs.
A. 52	2.30 a.m.	9.30 p.m.	General Electric Co.	WGY 380 m.	Schenectady, New York.	Sat.—Dance Music.	—
A. 53	3.0 a.m.	8.0 p.m.	"Morning Oregonian."	KGW 492 m.	Portland, Oregon.	Mon. & Wed.— Concert. Tues. & Fri.— Talk.	—
A. 54	3.30 a.m.	10.30 p.m.	Willard Storage Battery Co.	WTAM 390 m.	Cleveland, Ohio.	Mon.—Dance Pro- gramme.	2½ hrs.
A. 55	3.30 a.m.	10.30 p.m.	General Electric Co.	WGY 380 m.	Schenectady, New York.	Fri.—Musical programme.	—
A. 56	4.30 a.m.	11.30 p.m.	General Electric Co.	WGY 380 m.	Schenectady, New York.	Tues. & Thurs. Organ Recital.	—
A. 57	4.30 a.m.	10.30 p.m.	Woodmen of the World.	WOAW 526 m.	Omaha, Nebraska.	Tues. or Thurs.— Entertainment. Fri.—Relayed Or- chestra.	—
A. 58	4.30 a.m.	11.30 p.m.	Westinghouse Electric & Mfg. Co.	WBZ 337 m.	Springfield, Mass.	Tues.—Organ Recital.	—
A. 59	5.15 a.m.	11.15 p.m.	Woodmen of the World.	WOAW 526 m.	Omaha, Nebraska.	Sat.—Entertainment.	—
A. 59a	6.0 a.m.	10.0 p.m.	"Morning Oregonian."	KGW 492 m.	Portland, Oregon.	Wed. & Sat.— Dance Music.	—
A. 60	6.0 a.m.	midnight.	Westinghouse Electric & Mfg. Co.	KYW 536 m.	Chicago, Ill.	Sat.—Hotel Band Relayed.	2 hrs.

REPRESENTATIVES WANTED.

RADIO PRESS LIMITED desire to appoint a number of Resident Sales Representatives, one in the vicinity of each main Broadcasting station. Applications are invited from young men of business ability and initiative, possessing some knowledge of wireless. Applications should be made by letter stating age, previous experience and salary required, addressed to Sales Manager, Radio Press Ltd., Bush House, Strand, W.C. 2.

Duodyne

A Genuine Long Range LOUD SPEAKER RECEIVER TWO Stages High Frequency Amplification

AUTOMATIC TUNING

GUARANTEED RANGE
under average conditions

- DUODYNE III. Headphones .. 3/4,000 miles.
- DUODYNE V. Headphones .. 4/5,000 miles.
- LOUD-SPEAKER .. 1/1,200 miles.

THE DUODYNE Long Range Receivers will discriminate between Radiola, Paris and 5XX Chelmsford, or used in conjunction with a CURTIS EJECTOR will tune in any Broadcasting Station at will, while operating 1 1/2 miles from local Station or 200 yards from Relay Station.

The extraordinary range and simplicity of operation of these receivers makes an irresistible appeal in Imperial and Continental markets.

A CHILD CAN TUNE IT.

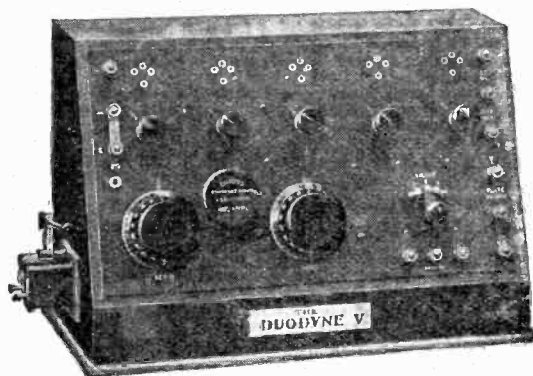

The DUODYNE III. (Instrument only) Panel Type £10 0 0

The DUODYNE V. (Instrument only) Panel Type £18 18 0

The DUODYNE CABINET.—The Duodyne V. is also supplied in French Polished Oak Cabinet with folding doors, enclosed valves and tuning coils. Self-contained batteries. Instrument only .. £27

CURTIS CONSTANT - TUNED H.F. AMPLIFIER

The Curtis "Constant-Tuned" High Frequency Amplifier is the only automatic high-frequency amplifier which, when connected in circuit, guarantees high efficiency for two stages of radio amplification on any wavelengths between 300 and 3,000 metres, and requires no additional controls, NOR MORE EFFORT, SKILL OR PATIENCE IN TUNING, THAN IS REQUIRED FOR THE OPERATION OF THE USUAL ORTHODOX SINGLE STAGE TUNED ANODE CIRCUIT.

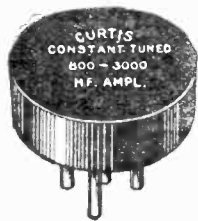

THE CURTIS CONSTANT-TUNED HIGH-FREQUENCY AMPLIFIER CHANGES THE WHOLE CHARACTER AND QUALITY OF WIRELESS REPRODUCTION.

And with its automatic simplicity, combined with increased selectivity and power, is destined to make two stages of high-frequency amplifications a sine qua non of every Wireless Receiver for the Experimenter and Home Constructor, or the purchaser who prefers to buy a professionally constructed instrument.

For the greater convenience of the constructor, and so as to conform with existing panel design, the Curtis Constant-Tuned High-Frequency Amplifier is designed with the orthodox 4-pin plug for panel mounting and must be connected up in accordance with the circuit diagram supplied.

Type A 300 to 800 Metres. Price 15/- Postage 6d.
Type B 800 to 3,000 Metres. Price 17/6

BUILD your own automatically tuned **LONG-DISTANCE RECEIVER.** Set of parts, including drilled and engraved Paragon Panel and Polished Mahogany Cabinet, with suitable circuit diagrams.

From **£4 15s. 0d.**

THE SILVER GHOST CRYSTAL RECEIVER

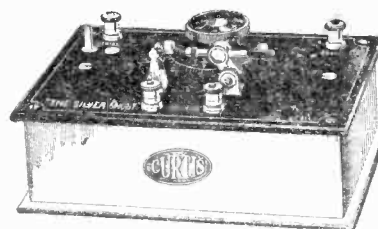

With its richly engraved panel and plated fittings mounted on a polished aluminium casket, combines the exclusive efficiency and elegance of a Curtis Radio Instrument.

Price - - 30/-
ELEGANT REFINEMENT.

PARAGON CURTIS Products are always of uniform and dependable quality. Ask your local agent for full particulars and illustrated Catalogues.

PETER CURTIS LTD.
75 · CAMDEN ROAD · N.W. 1.
Telegrams: "PARACURTEX" — 'Phone: NORTH 3112.
IN CONJUNCTION WITH
The PARAGON RUBBER MFG. CO. LTD.
HULL

BIRMINGHAM: 76, Newhall Street. Central 7236.
MANCHESTER: 312, Deansgate. Central 5335.

particular piece or pieces of "furniture" which sometimes gives it its name, the Bridal Chamber, for instance, having the most wonderful four-poster bedstead formed of glistening stalactites and stalagmites, which gleam white in the brilliant light turned on to them. One can hardly credit that a perfect statuette of the late Queen Victoria, situated high up in a niche in one of the chambers, is not the work of man. There are many such "formations," Moses on the Mountain, the Madonna and her Child, etc., with a tolerably good drawing on one of the walls of a motor-car and a steam-boat, both, strange to say, side by side, but undoubtedly produced by Nature long before man ever thought of a steam engine, to say nothing of the motor-car depicted on this underground wall.

I said the journey to King Solomon's Mine was somewhat difficult. With a six-valve Marconiophone wireless set and its attendant paraphernalia it would be not only difficult, but dangerous—for the six valve set. The footway is slippery, Tunnels just admitting a fairly stout individual have to be negotiated on all fours, there is a slide down a sloping flat rock into the dark unknown, and also a "chimney" to be climbed. It will therefore be readily understood why, when I took a wireless receiving set into the Congo Caves recently, I called a halt in Van Zyl's Hall, a chamber about five hundred feet from the entrance to the caves. When I say that in this chamber I erected a regulation size single-wire aerial, one hundred feet, across a *segment* of the hall, which is almost circular, readers will realise its size. The height, I may say, is proportionate to the width.

The Journey

Let me now briefly state how the caves are reached so far as the visitor from Cape Town is concerned. There is a train journey of about four hundred miles before Oudtshoorn is reached, the train passing through two ranges of high mountains. From Oudtshoorn the trip to the caves is by motor-car, one of the most beautiful rides any traveller could wish for. More mountains are met with, then out into the open valley-land again, past the Congo Hotel, and once again into the mountains, this time rising in the car to a height of about eight hundred feet up the face of one of them, to the very entrance to the caves.

I was on a brief visit to Oudtshoorn, and had brought with me from Cape Town a Marconiophone six-valve set (five high-frequency), and a Marconiophone two-stage amplifier, having set out to privately experiment on the train journey. Whilst in Oudtshoorn I suddenly conceived the idea of attempting reception in the Congo Caves of wireless telephony, broadcast from Cape Town, about four hundred miles away, and from Johannesburg, about eight hundred miles away. So far as the general public and the broadcasting stations were concerned, I kept my intended visit quiet, feeling sure that I was on a wild goose chase, having regard to the nature of the country to be negotiated, not to speak of the fact that I was diving into the heart of a mountain.

earth wire connected to that. We might just as well have driven the pipe into the roof, if we could have got there. Connections were soon made, and the valves were turned on.

Wonderful Reception

Our doubts were soon at rest. Strange to say, the first words heard by wireless in the Congo Caves were "Cape Town calling." (Cape Town has no abbreviated call sign). There we were, four hundred miles from the broadcasting station, well underground, and yet, on the loud speaker, we got the most perfect wireless music I have ever heard. Oudtshoorn is known for its supply of atmospheric, and we heard all about them the next day from owners of sets, but, in our weird surroundings, there was an almost complete absence of them. I got as far from the loud speaker as I

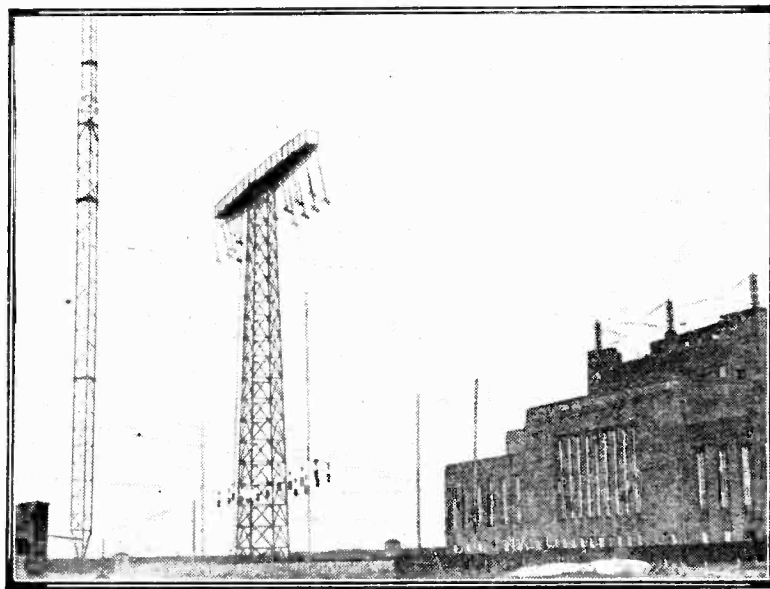

The huge aerial of the Nauen Station is now used for broadcasting.

Erecting the Aerial

My little party, in two motor-cars, arrived at the caves a few minutes after eight o'clock at night. Each member of the party was given something to carry, and the long narrow passage, with the steps down to the floor of Van Zyl's Hall, were quickly left behind, and we crossed over to the far side of the Hall. The erection of the aerial was the easiest thing I have ever done in that line, one end being secured to a stalactite on one side of the chamber, and the other to a rope fastened to a similar ready-made mast on the other side. A piece of water piping was driven into the ever moist floor, and the

could, that is, just about the length of the aerial, and every word of a talk on "Angling" could be heard distinctly. The old guide told me that many European singers have tried their voices in this same hall, and have remarked on its wonderful acoustic properties. Johannesburg, eight hundred miles distant, was next tuned in, again with unlooked for success. It was all too wonderful, almost too wonderful to be true. "J.B." came through with good, healthy, loud-speaker strength though a station of weaker power than Cape Town, and there was no mistake about it, we could help ourselves to whichever station we wanted.

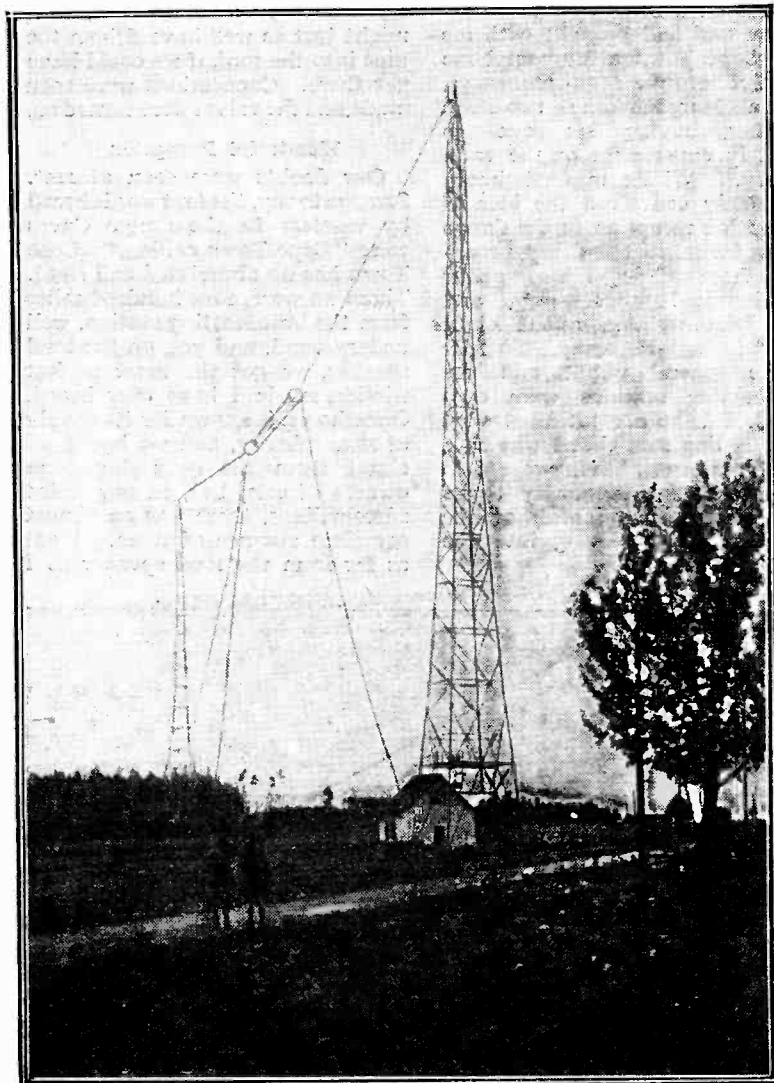

The aerial of the Zurich Station, which is becoming one of the "regulars" heard in this country.

FOR listeners who are unfamiliar with foreign languages there is no doubt a certain difficulty, despite the information I have already given, in recognising Stations abroad. Unfortunately, Continental Stations for some reason have not adopted our method of allotting call signs to all their Stations. In addition those which do possess call signs do not appear to make use of them for identification purposes whilst transmitting. It may appear to readers, in view of these facts, that the giving of call signs in Continental Broadcasting Tables is of little use. I would suggest, however, that this is not entirely the case, as these call signs allow readers to identify with certainty the Station mentioned, in reference to particular transmissions, when there are several Stations in the same town or the same locality.

It will be my endeavour in this short article to help readers to identify the Stations to which they may be listening, and for the benefit of those who are not familiar with foreign languages I propose giving some of the methods of calling in a phonetic manner.

German Stations appear to be coming in rather well at present, and are frequently received by listeners trying for the distant B.B.C. Stations, as often the same set of coils is used in both cases.

The German Stations

The numerous German Stations are very close together on the wave band used. The nine main Stations have their wavelengths distributed between 395 and 505 metres.

All these Stations have no call signs allotted to them, but

**Continental
Methods of
Calling**

By

Captain L. F. PLUGGE,
B.Sc., F.R.Ae.S., F.R.Met.S.

when the announcer calls out the name he invariably gives also the wavelength on which the Station is working, and listeners should try to make use of this number representative of the wavelength in metres as the call sign of the Station, and in this manner identify it by the tables.

In order to help listeners to do this, I would add that the number representing the wavelength is preceded by the word "welle," which means "wave" in German, and which is phonetically pronounced "vella"; this number is not followed by the word "metres," but generally forms the last words of the calling sentence. For example, Münster would announce as follows:—"Hier Münster auf Welle vier hundert zehn." The last three words of this sentence mean 410.

Methods of Announcing

This manner of giving out the wavelength is common to all German Stations, and I think that listeners will find it easier to recognise them in this manner than by the name of the Station.

Another reason for this is that there is no consistent manner in which the German Stations have received their names. Some of them use as names that of the town in which they are situated, others the full name of the company which owns the Station, others a coined word generally made up of the initials of the words forming this name. These coined words are quite difficult to catch. They invariably terminate with the syllable "a.g.," pronounced "arg," these two letters standing for "aktien gesellschaft," meaning "limited company," and generally form the last two words of the description of the company owning the Station. As an example, the Hamburg Station is run by the

In this special article the author of our Continental Broadcasting Tables, to which the numbers given refer, gives some interesting particulars as to how these Stations may be recognised.

"Nordische Rundfunk A.G.," and styles itself "Norag." The Leipzig Station, run by the "Mitteldeutsche Rundfunk A.G.," calls out "Hier Mirag."

On the other hand, the Berlin Station Voxhaus calls "Hier Berlin," and the Munich Station "Hier der Deutsche Stunde in Bayern," which means the German hour in Bavaria, and is the name of the company running the Munich Station.

A Summary

Summarising what I have said for this series of short wave German Stations, the best way for listeners is to identify them by means of the number representing the wavelength and to try to confirm this by trying to notice the name used by the Station in each case.

For those using sets capable of tuning to the high wavelengths there will be no difficulty in receiving and identifying the high-powered German Station of Königswusterhausen, which works on 2,800 metres with a power of 5 kilowatts. The only transmission sent out by this Station on that wave takes place every Sunday at 10.50 a.m. punctually, the announcer invariably calling out, "Hier Königswusterhausen auf Welle zwei tausend acht hundert," sixty seconds after the last dot (10.49 a.m.) of the Eiffel Tower time signal of 10.44 a.m., which can also be usually heard on the same coil—Ref. Nos. 96 and 95.

Zurich and Vienna

There are, however, other Stations than the German Stations that use the German language, these being Vienna and Zurich, the latter transmitting on 515 metres and the Austrian on 530 metres. Close to these two stations in wavelength we have Berlin on 505 metres. The Zurich Station is, however, by far the best to receive and the most powerful; this says a lot for this Station, as its power is small,

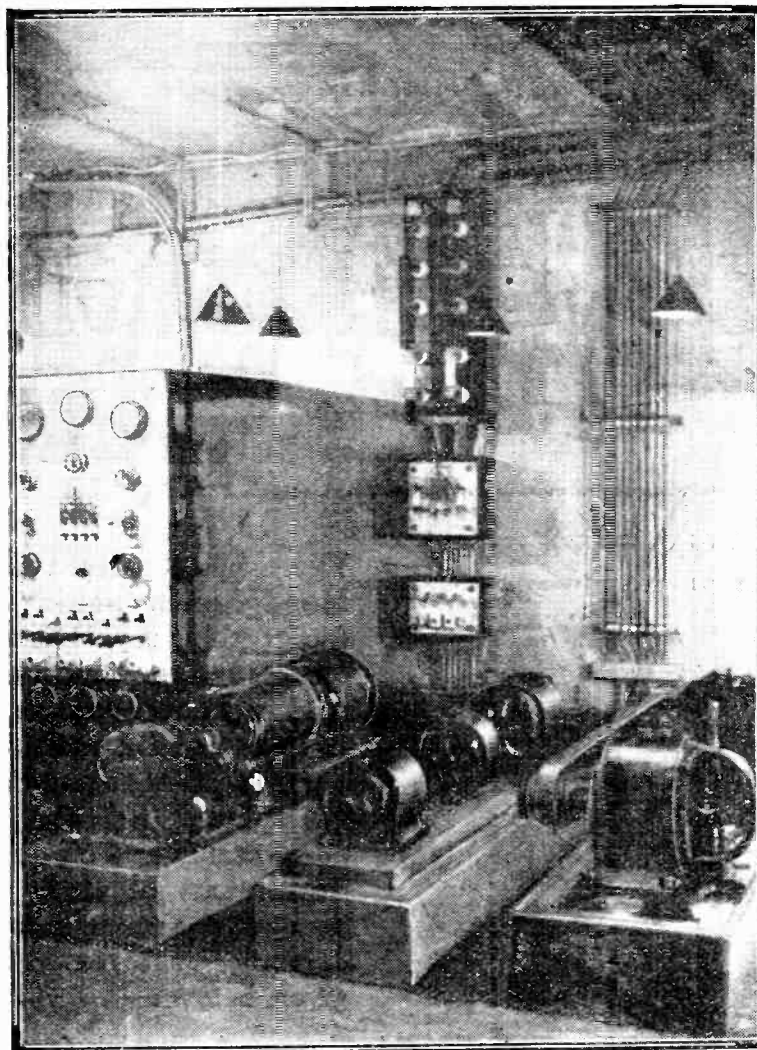

The generators used at the French Station of Postes and Telegraphes are seen in this photograph.

being 500 watts. The efficiency of its transmitting gear evidently makes up for the smallness of power.

The announcing of the Vienna Station is rather poor, and it is best recognised by its wavelength position relative to the two other Stations mentioned.

It is unfortunate, in this respect, that Continental Stations do not as a rule call out their identification names often enough, and one sometimes has to wait as long as half an hour (sometimes much longer) before it is given out. There is one exception to this, however, and that is the French Station of the "Petit Parisien," Paris.

The Petit Parisien.

This Station, which is owned by the important Paris daily paper, *Le Petit Parisien*, appears to be one of the most go-ahead Continental

Stations. It is equipped with Western Electric transmitting gear and its modulation is excellent. The announcer never fails to give out the Station's name before and after each item.

Unfortunately, this Station does not transmit regularly, as I am sure everyone would wish. Its days of transmission are Sundays, Tuesdays and Thursdays; but the Tuesday transmissions do not take place every week.

The Station of the *Petit Parisien* is a very interesting one for British listeners, and this for many reasons. In addition to the fact that its name is called regularly between each item of the programme, these items are announced in English as well as French. It continues with its concerts, which are of a high standard, some considerable time later than the B.B.C. Stations, and the wavelength of 310 metres which it uses is well within the

B.T.H. Headphones

The original pattern B.T.H. Headphones achieved a remarkable reputation for sensitiveness and tonal quality. Many improvements have since been made, with the result that to-day B.T.H. Headphones are the most comfortable and convenient instruments of their kind. Some of the more important constructional features are given below:—

Price
per pair **25/-**
(4000 ohms)
Weight with cord 9½ ozs.

- A The body is of special non-resonating material.
- B The stirrup moves freely within the slider, and takes up and retains its position without any locking device.
- C The stirrup cannot be completely revolved in the slider. Kinking and twisting of the cord are thus avoided.
- D The special slider adjustment obviates the use of screws
- E Spring steel headbands give the exact pressure required for perfect hearing with ut discomfort. There is no "scissors" movement.
- F The leather covering gives perfect comfort.
- G The earpieces fit closely to the ears.
- H Best quality flexible cord.
- I Ni.kel plated series connector.

Obtainable from all Electricians and Radio Dealers.

Advert. of The British Thomson-Houston Co., Ltd.
Crown House, Abchurch, London, W.C.2

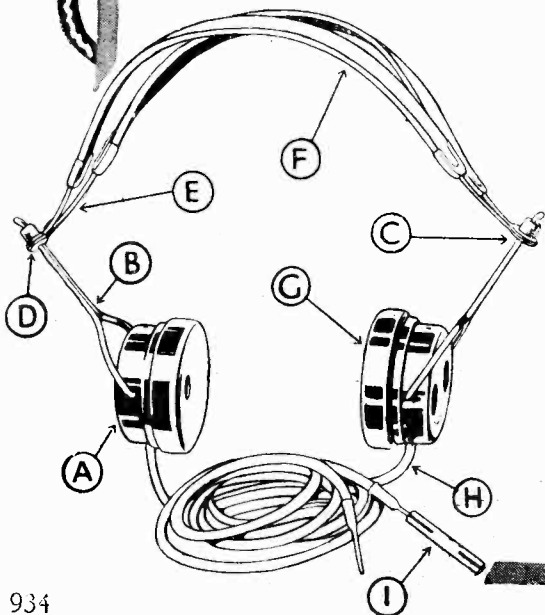

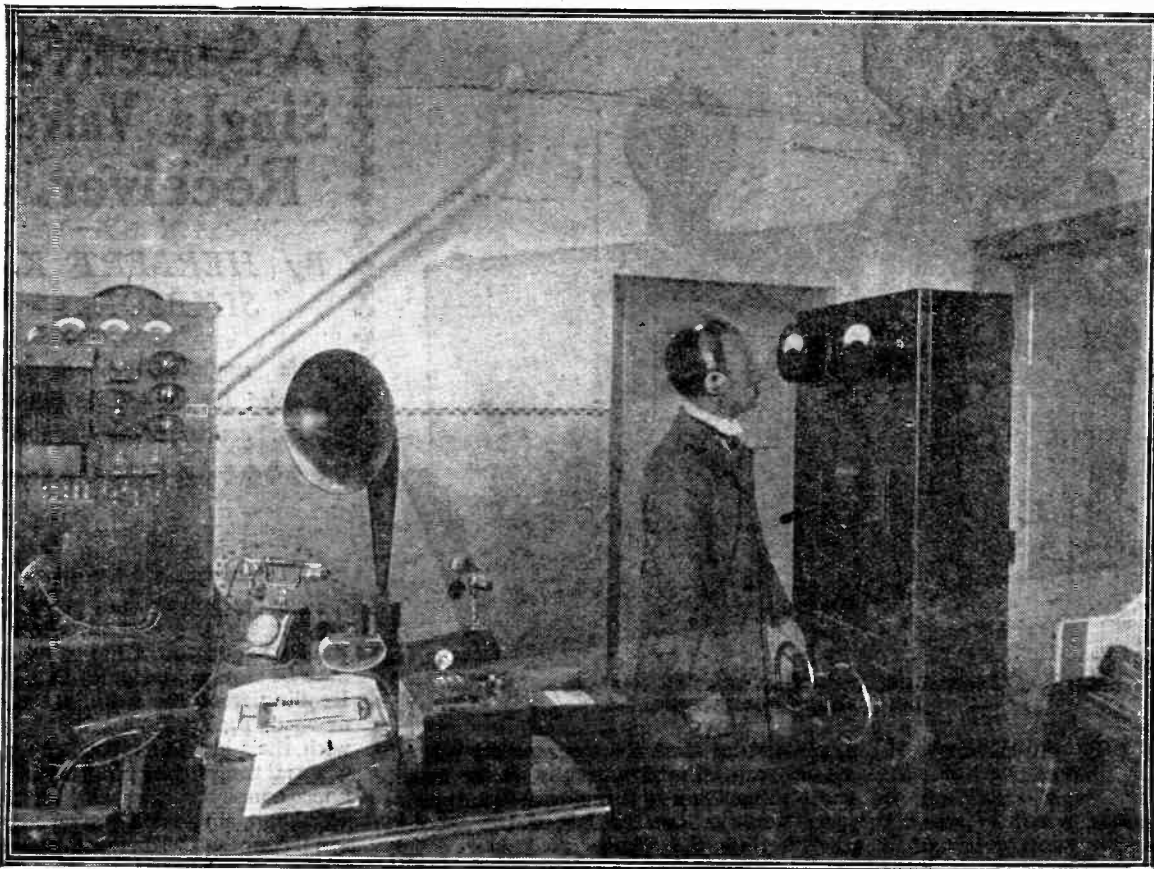

The control room at the Zurich Station.

reach of receiving apparatus designed to tune-in the B.B.C. Stations.

Reviewing the other French Stations, that of the Ecole Supérieure des Postes et Télégraphes working on 450 metres has to be recognised by its wavelength and by the fact that French is spoken, as it rarely calls out its name except at the beginning and the end of a transmission—an interval of some three hours generally. This slackness in giving out the call signs is largely explained by the fact that the Station generally transmits outside broadcast and is, among all the Stations in Europe, that which does the most outside broadcast work.

The Eiffel Tower

The Eiffel Tower, which might have been mentioned at the beginning of this article, as it is one of the first stations on this side of the Atlantic to start broadcasting, is probably one of the easiest Stations to recognise, because of its high wavelength and also by its very easily distinguishable time signals, which are sent out on spark and on the same wavelength as the telephony.

Beginners wishing to tune in this Station are advised to try

first for these time signals. Several are given in the tables, but I would recommend transmissions number 10, 79, 89 and 133, which take place at 10.0 a.m. and 10 p.m. every day.

These signals consist of a series of 300 dots spaced at intervals of one second (to be accurate, 49-50ths of a second interval), the sixtieth of which is replaced by a dash. These signals can even be received on a crystal set in this country. The tuning of these spark signals will enable the beginner to get his adjustments to the proper wavelength of 2,600 metres.

Telephony will be received on this same setting, and if the test is made on a week-day at the 10 p.m. time signal, the experimenter need only stand by 10 minutes to receive the weather forecast report as stated under reference number 80.

The call used by the Eiffel Tower is "Allô, Allo. Ici la Station Radiotéléphonique de la Tour Eiffel."

Concerts transmitted from the Eiffel Tower are organised by the Society "Les Amis de la Tour Eiffel," but before this Society took over the management the Station was a military one, and the announcer used to begin by "Ici

le Poste Militaire de la Tour Eiffel." This manner of calling, however, has not been in use for the last year.

Many Stations could be referred to in such an article, but I cannot conclude without making some reference to the excellent Station of the Compagnie Française de Radiophonie.

Radio-Paris

This Station used to be known under the name of "Radiola," and owned by the Compagnie Française Radio-Électrique, with its studio at 79, Boulevard Haussmann. In those days the call was "Emissions Radiola de la Compagnie Française de Radiophonie," followed by the address of the studio. Since the erection of the company's high-power Station at Clichy, a suburb of Paris, its way of calling has changed to the following: "Allo. Ici Radio-Paris, Poste de Clichy."

I do not think listeners experience much difficulty in tuning-in this Station or identifying it.

Within the compass of this article it has been impossible to deal with all the Continental Stations I would like to have touched upon, but I trust the article will be of interest to readers.

For your Wonderful Year

When a wireless worker wants to be absolutely certain of the efficiency of a component he is buying, he says "It MUST be Bowyer-Lowe's!"

He does so because he knows that before it leaves our factory every part we make is put to tests far more severe than he will give it in practice.

In buying Bowyer-Lowe parts you are doubly pro-

tected. First, by our own test which guarantees you against faulty workmanship. Second, by our firm guarantee of replacement which safeguards you against faults that may have arisen through careless handling after our products have left our hands.

Bowyer-Lowe parts make sets of high efficiency. Insist on having them through 1925.

Bowyer-Lowe Tested Radio Components

Good dealers stock all the components illustrated in this advertisement. They are described below:—

1. SQUARE LAW CONDENSERS. They have the highest capacity ratio in wireless (150 to 1 in the .0005). Unequalled selectivity and wavelength range, with exceptional purity of reception, results wherever they are installed. Single, double and triple types made in all the usual ranges. Prices from 11/6.
2. ANTI-CAPACITY VALVE HOLDER. Made at suggestion of Mr. P. W. Harris for high efficiency, especially on short wavelengths. No metal nuts or bolts needed for fixing. The ebonite base plate is tapped. Lacquered finish. Price 1/2.
3. PLUG-IN H.F. TRANSFORMER. Perfect match-

ing of every one in a range absolutely guaranteed. The most efficient and economical Transformer obtainable. All ranges from 150 to 3,000 metres and up. Uniform price for any range 7/-.

3A. NEUTRODYNE UNIT. A special Plug-in Transformer for Neurodyne circuits to cover range of 300 to 600 metres without using two transformers. Made at suggestion of Mr. P. W. Harris. Price 7/- each.

4. VALVE WINDOWS. American pattern. Front plate with rounded edge on outer and inner circumference. Back plate and all nuts, etc., supplied. The whole heavily nickel plated. Outer diameter 1 1/2 inches; inner, 1 inch. Price complete 9d.

5. WAVEMETER. A Three-in-one Testing Device for calibration, wavelength

checking, and use as wavetrap. Instrument mounted on ebonite in Mahogany Case. A most valuable instrument for every experimenter. Full instruction provided. Price £4 4s.

6. TESTED EBONITE. Guaranteed free from metal, P.O. Grade "A." Sold in sealed packages. Semi Matt 1d. per square inch. Polished one side and edges: 1d. per square inch. Drilled and engraved for any Radio Press Set (except OMNI top panel): 1d. per square inch. Useful hints on plotting, etc., with every sheet.

7. NEUTRODYNE CONDENSER. An efficient neutralising condenser having minimum capacity practically zero and maximum lower than the minimum of ordinary condensers. One screw fixing. Drilling template supplied. Price 5/-.

Bowyer-Lowe Co., Ltd., Letchworth.

All good dealers stock our products. In case of difficulty write direct.

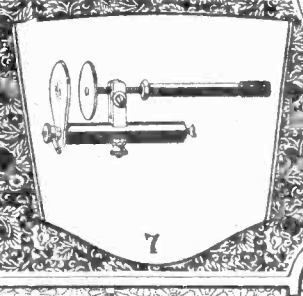
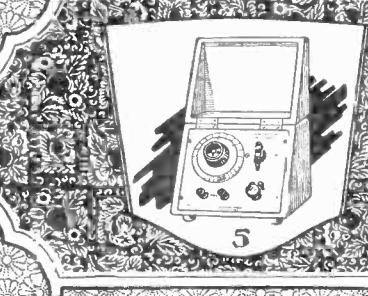
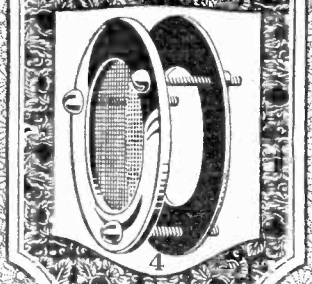
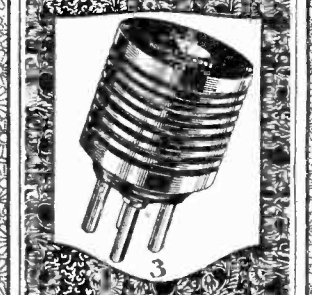
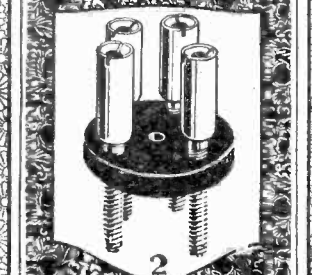
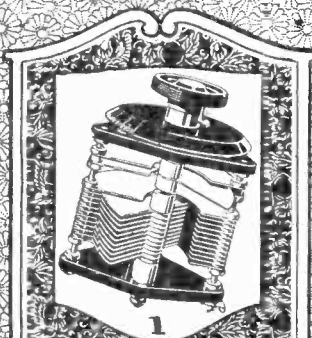

the grid of the valve through the grid condenser C_2 of $.0003 \mu F$. R_2 is the grid leak having a fixed value of 2 megohms. In the anode circuit of the valve are the reaction coil L_3 , variably coupled to L_2 , and the telephones T shunted by the fixed condenser C_3 of $.002 \mu F$.

The Different Forms of Aerial Tuning

Direct coupling with constant aerial tuning is obtained by joining T_2 to T_4 by means of the flexible wire and Clix shown in Fig. 5, and T_6 to T_5 with a piece of stiff wire as in Fig. 3. The aerial is then joined to T_1 and the earth to T_3 . The parallel arrangement without constant aerial tuning is obtained by disconnecting the aerial lead-in from T_1 and joining it to T_2 , the other connections remaining as before.

Series tuning is brought into use by joining the aerial to T_6 and T_5 to earth, all other connections being broken.

For loose coupled aerial tuning it is necessary to join T_2 to T_3 , T_5 to T_6 , aerial to T_2 , and earth to T_5 . Constant aerial tuning will not be used, of course, with the loose coupled circuit.

Components Required

The set is not expensive to build, and the constructor is not advised to economise by purchasing components of inferior quality, for except in a few isolated cases it has been found cheapest in the end to use components of guaranteed reliability. It is not absolutely necessary, of course, to purchase articles of the same manufac-

ture as those used in the present instance, but components of doubtful quality should be avoided.

The components are as follows, and names of makers are given for the reader's convenience should it be desired to exactly duplicate the set:—

Ebonite Panel, 12 in. by 6 in. by $\frac{1}{4}$ in. ("Red Triangle," Peto-Scott, Ltd.).

Cabinet of suitable dimensions.
3-coil holder (Polar Vernier, Radio Communication Co., Ltd.).

$.0005 \mu F$. variable condenser with vernier ("Utility," Wilkins and Wright).

Valve holder (Burndept, Ltd., "Antiphonic").

Dual rheostat (Burndept, Ltd.).
1 $.0001 \mu F$. fixed condenser (Dubilier).

1 $.002 \mu F$. fixed condenser (Dubilier).

1 $.0003 \mu F$. fixed condenser (Dubilier).

1 2 megohm grid leak (Dubilier).

10 W.O. type terminals (K. Raymond).

6 Clix sockets (Autoveyor, Ltd.).

5 Clix plugs: 2 red, 2 green, 1 blue (Autoveyor, Ltd.).

Quantity of square wire for wiring up (Sparks Radio Supplies).

1 packet of Radio Press panel transfers.

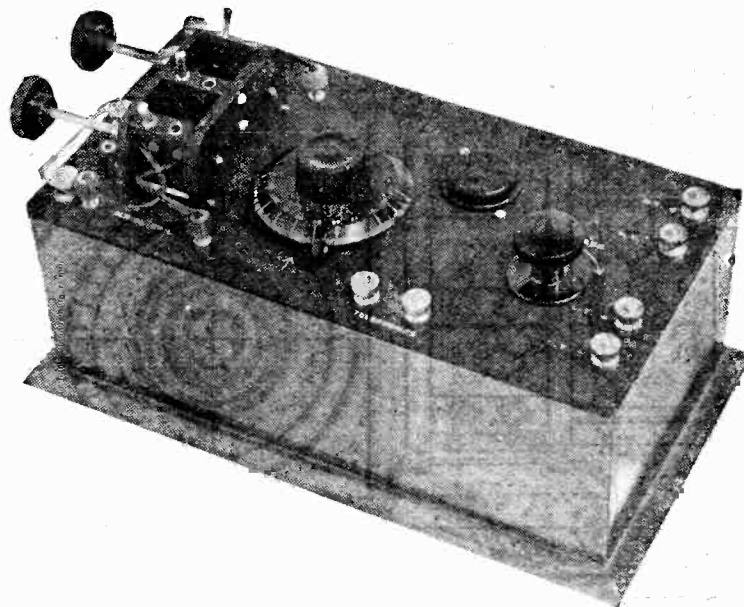

Fig. 3.—With coils and valves removed, the panel layout is clearly seen.

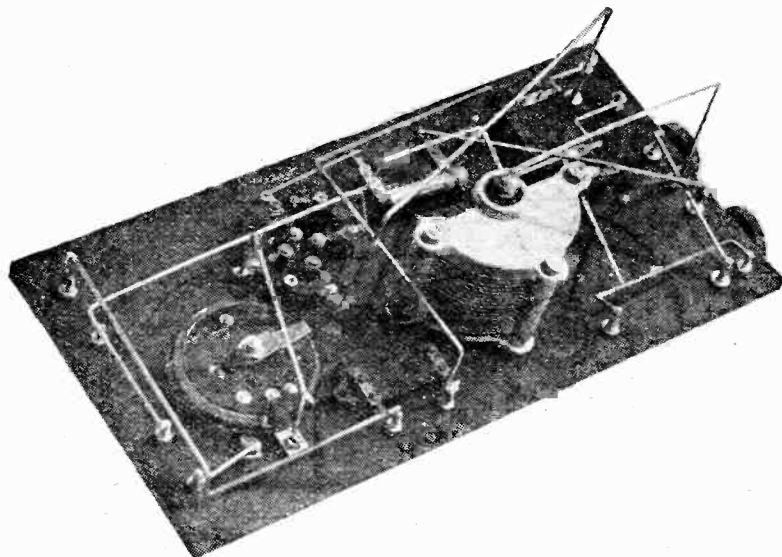

Fig. 4.—A helpful view of the wiring, showing where the fixed condensers are placed.

Drilling the Panel

It is now unnecessary to risk being troubled with the faults which arise from using poor quality ebonite (which in some cases is ebonite only in name), for a number of manufacturers now guarantee their panels to be free from any leakage. Having purchased such a panel, drilling may be carried out with ease on referring to Fig. 5, which shows the positions of all the necessary holes. The sizes of the holes should be determined when the actual component to be mounted is to hand. It is advisable to mark the panel with the transfers before assembling the components.

Mounting the Components

This is a simple stage in the construction of the set, it being necessary only to refer to the photographs and diagrams of the

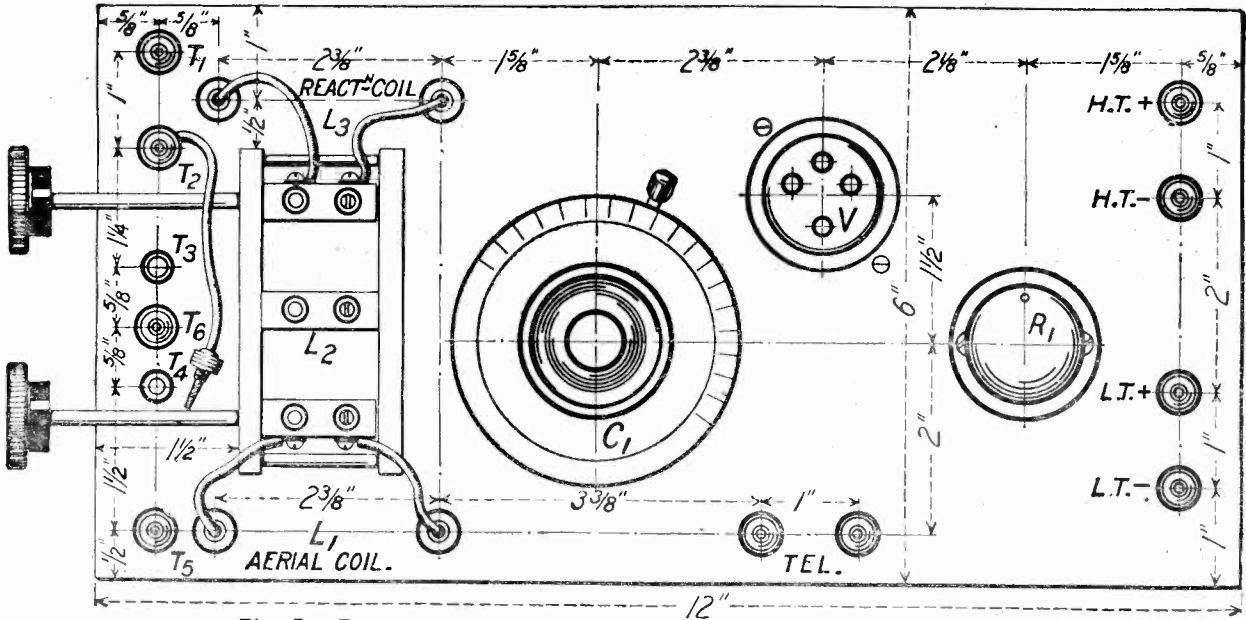

Fig. 5.—Front of panel drilling diagram. Blue print No. 82A.

receiver to ascertain the correct positions for the various components. The fixed condensers are the only components left unmounted, these being secured in position during the process of wiring.

Connecting Up

All that is needed to make a successful job of the wiring of the receiver is a careful study of the wiring diagram and the photographs of the back of the panel.

The three fixed condensers have their values clearly marked in the wiring diagram, and are secured by soldering their tags to terminals or wires. Two rubber covered

flexible leads are secured to a Clix socket and a stiff wire connection as in Fig. 6, after which they are taken through two holes in the panel, and connected on the other side to the terminals of the centre socket of the three coil holder.

The remaining necessary connections are seen in the drilling diagram, Fig. 5, these being the securing of four flexible leads, each terminated by a Clix plug, to the terminals of the two outside coil sockets, and also the connections of another Clix terminated lead to T₂. The colour of the latter Clix plug is blue, while those connected to the aerial and reaction sockets are green and red respectively.

How to Use the Receiver

The set is quite simple to operate using any of the forms of tuning mentioned previously. However, it is advisable for the beginner to use direct aerial coupling with constant aerial tuning first of all. The set should therefore be arranged to work thus in accordance with the instructions already given. The low-tension battery is always connected to the terminals L.T.— and L.T.+, while the high-tension battery is connected to H.T.— and L.T.+. The correct H.T. voltage depends upon the type of valve employed, and this is always given by the maker. The telephones, of course, are connected to the two

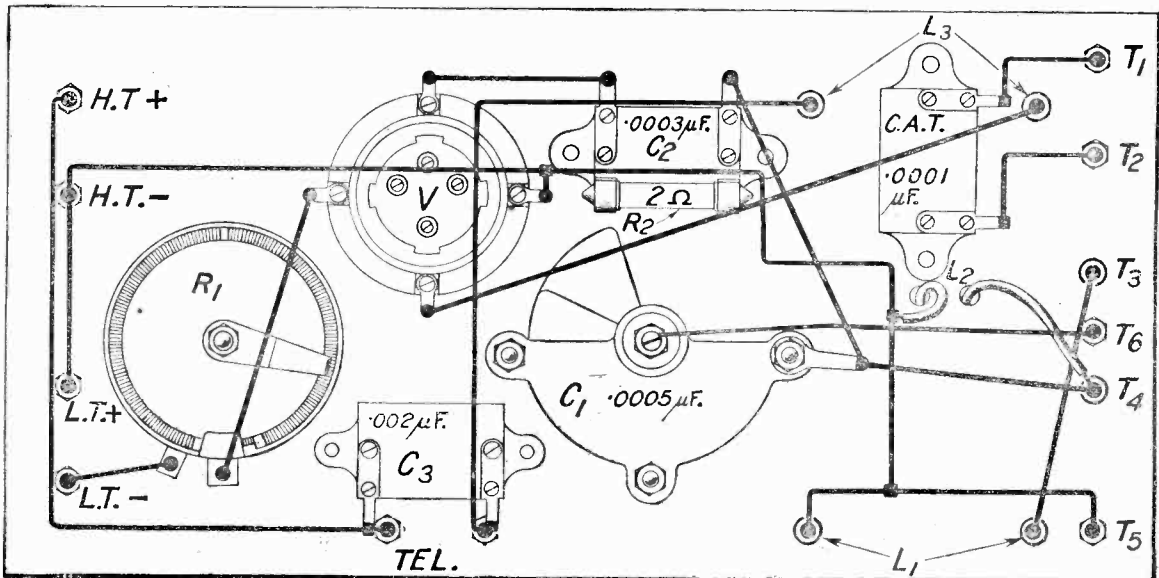

Fig. 6.—Back of panel wiring diagram. Blue print No. 82B.



Trial and Error.

You remember the beaker full of solution which you had to weigh in your schooldays.

You placed it in one balance pan and put weights in the other. Then you lifted the beam to see whether you had put in too many weights or too few.

In the end you got the weight right—by trial and error. The trial and error method of arriving at a result has to be resorted to in some cases, but it is both expensive and unnecessary to apply it to buying condensers and resistances for wireless sets.

Do not experiment with cheap or unknown components in the belief that you are effecting an economy. Even if your set appears to give quite good results for a while you will never feel proud of it if the components have been skimped.

See that you get products that bear the name of Dubilier; they are naturally somewhat expensive because of the materials and workmanship put into them; but if you fit them in your set in the first place you will eliminate all the process of trying unsatisfactory ones in order to discover the best.

You will discover the best without resorting to trial and error if you—

Specify Dubilier.

*Note our New Address
and Telephone Number.*



DUCON WORKS,
VICTORIA ROAD,
NORTH ACTON,
LONDON. W.3.

DUBILIER
CONDENSER CO. LTD

Telephone :
Chiswick 2241.
Telegrams :
Hivoltcon, Phone,
London.

MAGNIPLEX AERIAL

:: We guarantee to improve your reception in strength, clearness and range ::

What one of our many Users says:—"I obtained excellent results from the Bournemouth Station (80 miles) with a Crystal set of my own construction. Your 50 feet replaced a double 40 feet which I had previously used with uncertain results."

High tensile phosphor-bronze wire gauze. "Strong as Steel."

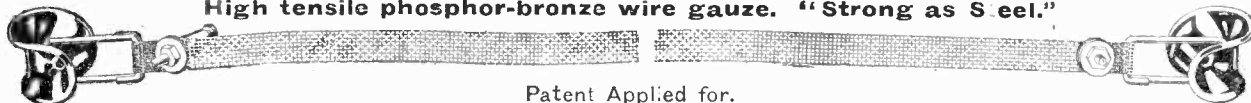

Patent Applied for.

GUARANTEE :—If you are not satisfied that Magniplex Aerial is worth the additional cost, return it in good condition and your money will be refunded.

PRICES :— $\frac{3}{4}$ in. wide 3d. per ft. ; $\frac{1}{2}$ in. wide 2d. per ft. Supplied in lengths of 50, 75 and 100 feet, including fittings, viz. : End Terminal for Down Lead and Insulators ready for erecting. For lengths under 50 ft. fittings charged rs. 3d. extra. Postage and packing free.

HELIXO LTD., 'Phone : Museum 6039.

Henry Buildings, Gresse Street, Rathbone Place, London, W.1

SEND FOR CIRCULAR AND USERS' TESTIMONIALS.

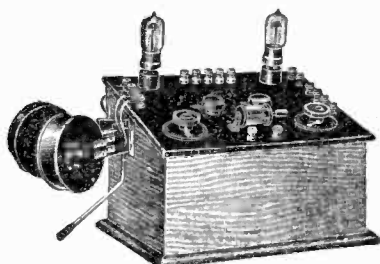

THE S.T. 100.
(Envelope No. 1.)

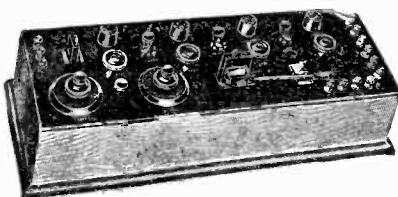

THE 4-VALVE FAMILY.
(Envelope No. 2.)

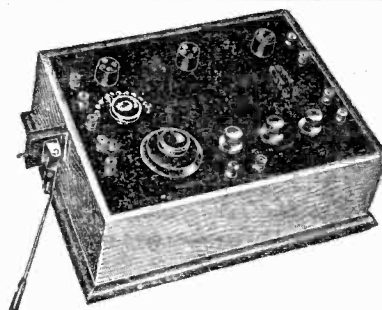

THE SIMPLICITY 3.
(Envelope No. 3.)

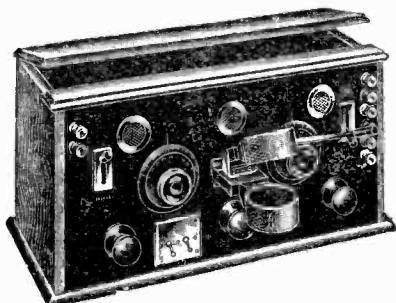

THE ALL-CONCERT-DE-LUXE.
(Envelope No. 4.)

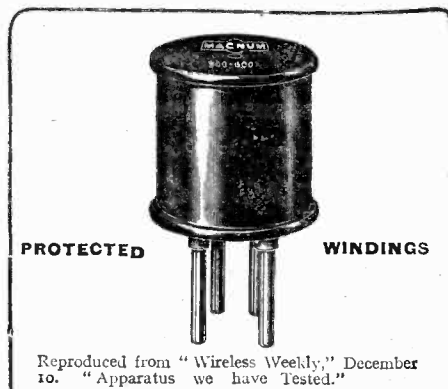

PROTECTED WINDINGS

Reproduced from "Wireless Weekly," December 10. "Apparatus we have Tested."

"Magnum" Plug-in High-frequency Transformers.

On test, the range indicated was exactly covered with a .0003 mfd (actual) tuning condenser, and the two samples showed quite close correspondence in their tuning. The insulation-resistance between windings was excellent. In actual reception the usual degree of amplification associated with fine-wire plug-in transformers was obtained; and in the modification suggested by Mr. Harris of the writer's neutrodyne tuned-anode coupling, using the one winding as a tuned anode and the other as the neutrodyne coil, good stable amplification resulted with a very small neutrodyne condenser in a circuit loose-coupled to the aerial. The finish and workmanship of these transformers was all that could be desired.

Wave-length ranges with a .0003 mfd. variable condenser.

No. 0	150—300 metres.
No. 0A	250—525 metres.
No. 1	300—600 metres.
No. 2	550—1200 metres.
No. 3	1100—3000 metres.

Price 7/- each.
Guaranteed correctly matched 14/- per pair.

Carriage and Packing Free on RETAIL ORDERS value £2 and over.

BURNE-JONES & Co., Ltd.
Magnum House, 288, Borough High Street,
Telephone : HOP 6257. LONDON, S.E.1.



Type L. for Transatlantic V, 4-Valve Family, etc.

3-Way, for Omni, All-Britain, etc., etc.

Type R., for S.T. 100, Simplicity 3, All Concert-de-Luxe, 3-ValveDual, Puriflex, etc.

9/6

12/6

9/6

Postage 6d. Postage 6d. Postage 6d.

Anode Coils tapped and complete, as used in the Simplicity 3 and T.A.T. 8/- post free.

Send stamp for Illustrated List and set of leaflets dealing with S.T. 100, 4-Valve Family, Simplicity 3, All Concert-de-Luxe, Omni, Transatlantic 4, Transatlantic 5, Puriflex, All-Britain, 3-Valve Neutrodyne, Tri-Cell, P. W. Harris Crystal Set, Magnum Coils and Coil Holders.

MAGNUM TAPPED COIL.



No. 1 .. 12/6
No. 2 .. 15/-

No. 1 equivalent to Nos. 25, 35, 50, 75 Plug-in coils. No. 2 equivalent to Nos. 100, 150, 200, 250 Plug-in coils.

1 lb. Hank No. 16 D.C.C. Wire for P.W. Harris Crystal Set, 3/- post free.

MAGNUM NEUTRODYNE CONDENSER.

Recommended for all Neutrodyne Circuits. 4/6 (Postage 6d.).

RADIO PRESS ENVELOPES.
Post free.

No. 1.	S.T. 100	...	1/8
No. 2.	4-Valve Family	...	2/9
No. 3.	Simplicity 3	...	2/9
No. 4.	All Concert-de-Luxe	...	2/9
No. 5.	Omni	...	2/9
No. 6.	A.B.C. Wave Trap	...	1/9
No. 7.	2 Valve Power Amplifier-de-Luxe	...	1/9
No. 8.	1/8
No. 9.	1/8
R.P.	Hot Pad Transfers	...	8d

terminals near the front edge of the panel.

B.B.C. Coils

For the ordinary broadcast wavelengths a No. 50 coil should be plugged into the fixed centre socket of the three-coil holder if the desired wavelength is below 420 metres, or if above 420 metres, a No. 75 coil should be used. A No. 50 or No. 75 coil should be inserted in the socket marked reaction. When first working the set the two coils should be kept as far apart as the coil holder permits, and tuning carried out by variation of the condenser dial until the required signals are heard. The reaction coil may now be brought towards the aerial coil, retuning after every small movement, on the variable condenser. If signals do not become louder as a result of this procedure, the connections to the reaction coil should be reversed by taking the two red Clix plugs from their sockets and changing them over. Care should be exercised to avoid making the set oscillate, by keeping the two coils as far apart as is consistent with good results. For distant reception, however, it is generally necessary to work fairly close to the point where oscillation begins and special care then needs to be taken.

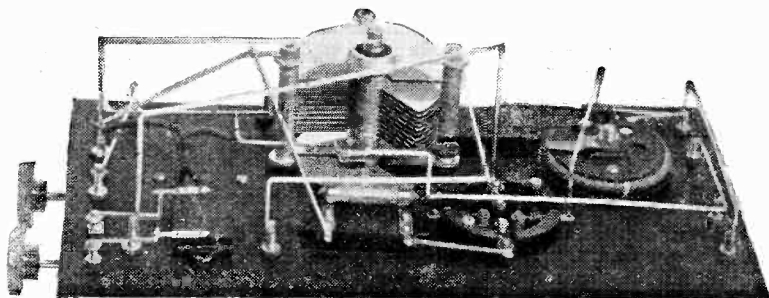

Fig. 8.—From this picture the relative elevations of the wires is made clear.

Loose Coupling

Having grasped the correct method of tuning, the arrangement in which the three coils are used may be tried. In this case the front moving socket is to hold the aerial coil L_1 . The secondary coil L_2 is to be inserted in the centre socket and the reaction coil in the rear moving socket as before. Since the aerial coil is untuned, only one aerial tuning adjustment is required. This is the variation of the coupling between L_1 and L_2 .

The reaction coil may again be a No. 50 or No. 75, and the secondary coil L_2 may also be a No. 50 or No. 75.

Different sizes should be tried

for the aerial coil, Nos. 25, 35, and 50 generally proving suitable. As a general rule, the coupling between L_1 and L_2 should be fairly close for loudest signals, although this does not always apply.

Selectivity

Obtaining good selectivity with little loss in signal strength is an art which has to be acquired. With patience, however, it is easily possible with this form of tuning to obtain greater selectivity than with direct aerial coupling. The method of tuning in a signal to the exclusion or partial exclusion of others is to loosen the coupling

between L_1 and L_2 and to retune on the condenser C_1 until a coupling is reached where maximum selectivity has been acquired and the signal desired is obtained with little or no interference.

Series Tuning

Series tuning may be tried (with direct aerial coupling) and the results compared with parallel tuning. A larger aerial coil than that used with parallel tuning without the C.A.T. condenser is generally required.

In conclusion do not be disappointed if at first you fail to get long range reception. Remember that conditions affecting reception

vary from one night to another, while the skill necessary to bring in distant transmissions is only acquired by practice. Once the skill has been acquired, however, excellent results on long distance reception will be obtained.

Test Report

The receiver was tested thirteen miles east of 2LO, on an aerial of average length and height.

At the commencement direct aerial coupling was used, with constant aerial tuning. A No. 50 coil was inserted in the aerial (middle) socket, while another No. 50 coil proved suitable in the reaction socket. After careful tuning the strength of the signals from 2LO became too great for comfort with the telephones. Seven other British stations and three Continental were then tuned in with ease in quite a short time.

The loose-coupled circuit was then tried, with the following coils in use: Aerial (front moving socket) a No. 35 coil; secondary (centre socket) a No. 50, and reaction No. 50. This arrangement was very easy to work, a fairly close coupling being found suitable for both short- and long-range work. A marked improvement in selectivity was observed, and critical adjustments of the aerial coupling proved convenient for final tuning of distant stations. By replacing the aerial coil with a No. 25 or No. 50 little difference was observed.

Chelmsford was received at excellent strength using direct aerial coupling without C.A.T., a No. 150 coil being employed in the aerial socket and a No. 200 in the reaction-socket. Equal strength was obtained with aperiodic coupling, the coil sizes in this case being: Aerial, No. 150; secondary, 250; and reaction 150 or 200. With the same coils Radio Paris was received at comfortable phone strength.

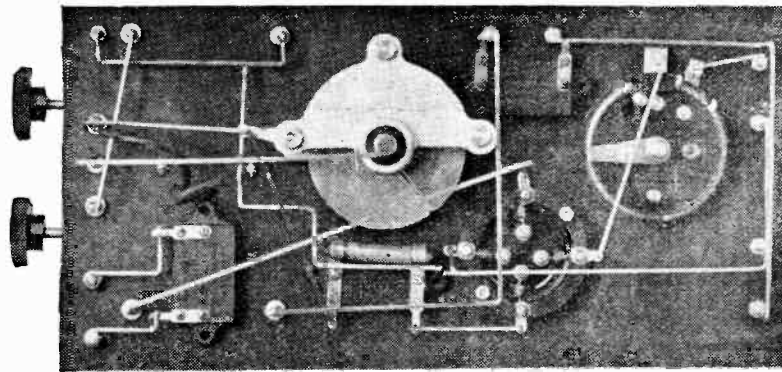

Fig. 7.—This plan view clearly shows how the connections go.

Your Earth Connection

By R. W. HALLOWS, M.A., Staff Editor.

A good earth means improved reception. In this interesting article many helpful hints on how to improve this important connection are given.

THERE are still large numbers of amateur wireless enthusiasts who fail to realise fully the importance of providing a thoroughly good earth connection for the receiving set. In fact the two most neglected portions of the receiving set are the high tension battery and the earth, both of which seem to be such simple and straightforward things that they can be left more or less to look after themselves. If ever a friend comes to see me with a sad tale of instability, of lack of selectivity or of poor signal strength and failure to pick up distant stations, the first thing that I want to know about is the earth. In nine out of ten of such cases examination discloses that it is defective, and after it has been set right there is a marked all-round improvement in results.

Earth Losses

Let us see first of all what effect a bad earth has upon range and signal strength. The effect of a bad earth connection is to introduce a resistance in the position occupied by R in the diagram. Hence an inefficient earth may lead to a very considerable loss of sensitiveness.

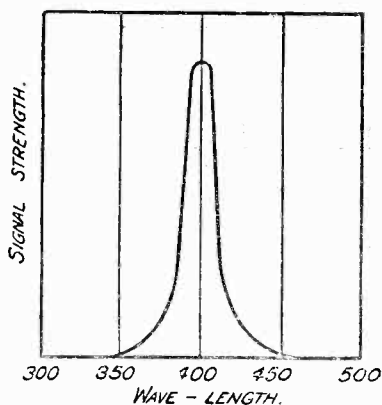

Fig. 2.—Oscillating circuits of low resistance tune sharply.

Selectivity

Now for selectivity. The addition of resistance in any high-frequency circuit has the effect of flattening the tuning. This means that instead of responding sharply to one frequency when tuned as finely as possible, the circuit will

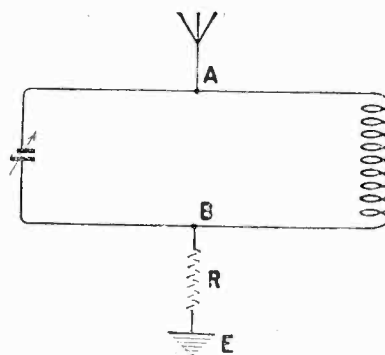

Fig. 1.—A bad earth is equivalent to a resistance in the earth lead.

be almost equally sensitive to a band of frequencies whose breadth varies according to the resistance. Figs. 2 and 3 show the effect of adding resistance to a tuned circuit. Most experimenters now realise the great advantage of winding inductances with heavy gauge wire in order to eliminate all unnecessary resistance, but it is of little use to use efficient inductances if at the bottom of the A.T.I. a large resistance is introduced by a poor earth connection.

Fig. 4 shows diagrammatically why a bad earth connection makes for instability in the set. Owing to the resistance R the negative end of the low-tension battery may be very much above earth potential, and the high-tension battery, the telephones and other large components are at a greater high-frequency potential than they should be with respect to earth. Further, you cannot bring the

cores of low-frequency transformers to earth potential, whilst the lower end of the secondary of a high-frequency transformer will also be above earth potential. All these large components are, so to speak, up in the air and the set becomes difficult to handle.

Effect on Stability

Not long ago I made a series of tests with a two-valve set provided with a very efficient H.F. amplifying stage with a view to ascertaining the importance of the part played by the earth connection in reception. The aerial adopted as standard was a good unscreened one standing on high ground, and in conjunction with it a first-rate earth, consisting of a large copper plate, buried in damp soil was available. When used with this the set gave remarkably good results, bringing in all the B.B.C. main stations at good telephone strength and not being at all difficult to handle. The effect was now tried of removing the 7/22 earth lead and substituting for it a piece of No. 36 copper wire, which

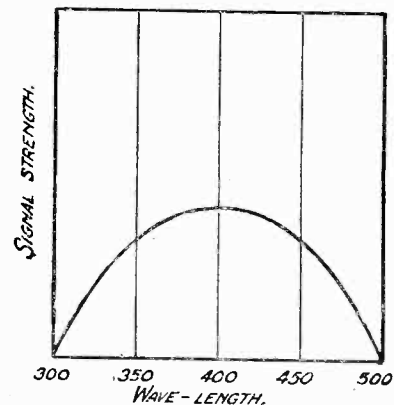
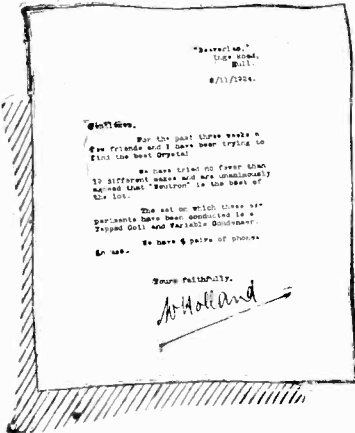

Fig. 3.—The presence of resistance flattens the tuning.

They tried 19 makes



Here is another remarkable letter of testimony, one of several received in the same mail. It is photographically reproduced on the left, and reads:—

"For the past three weeks a few friends and I have been trying to find the best crystal. We have tried no fewer than 19 different makes, and are unanimously agreed that 'Neutron' is the best of the lot. The set on which these experiments have been conducted is a Tapped Coil and Variable Condenser. We have 6 pairs of phones in use." . . . and did you notice the last sentence?—

"We have Six Pairs of Phones in Use."

Sooner or later, you will use Neutron, and then stop searching for better results. You may secure a good crystal by just asking for "a crystal"; but you may also try twenty or thirty first. On the other hand, if you ask for Neutron, in the black-and-yellow tin, you will inevitably secure optimum results

at once—and save the expense of further tests. The reason why you can depend on Neutron is that each Neutron is carefully tested and selected, and before ever it reaches your crystal-cup it has been proved at maximum efficiency, for loudness, clearness and complete sensitiveness.

and **NEUTRON** was
TRADE MARK
 the best of the lot'

Stocked by the Best Radio Dealers. Packed in tin, with silver catswhisker. Insist on Neutron, in the Black and Yellow Tin, **1/6**

Long-Distance
 Circuit Diagram
FREE

Ask your Dealer for Free Diagram (given on request to every purchaser of a Neutron) of the circuit used by SBT in receiving Brussels from Chiswick on a Neutron. We send one direct with sample Neutron if you enclose stamped envelope and 1/6 with Dealer's name.

Sole Distributors:—V. Zeitlin & Sons, 144, Theobald's Road, London, W.C.1. 'Phones: Museum 3795 and 6841.

Produced by:—Neutron Ltd., Sicilian House, Southampton Row, London, W.C.1. 'Phone: Museum 2677.

District Agents:

Scotland: R. F. Miller & Co., 22, York Place, Edinburgh.

Plymouth: Mumford & Sons, 68, Mutley Plain, Plymouth.

Birmingham: Cooke & Whitfield Wireless Ltd., St. Paul's Buildings, 24, St. Paul's Square, Birmingham.

North-East Yorks: Smith & Jordan, The Arcade, Redcar, Yorks.

Manchester: Garnett's, Islington Grove Works, Salford, Manchester.

Ireland: Pettigrew & Merriman Ltd., 8, Corporation Street, Belfast.

N. Staffs: H. W. Teeton, Foundry Street, Hanley.

The Concert-Tested and Guaranteed Radio Crystal



Home to those Wonderful Mullard Valves

The rain and biting wind seem to lose their power when you think of the happy evening before your cosy fire with a perfect wireless concert.

Those Mullard H.F. and L.F. valves make such a wonderful difference. You could almost thank them for the splendid enjoyment they give.

You are going back to all that makes life worth living: a welcome meal, your armchair, your pipe, and then the pure joy of broadcasting concerts.

If you have not yet experienced the wonderful difference these Master valves make in your radio reception, purchase them on your way home to-day and complete the pleasure of your winter nights.

Mullard H.F. Red Ring Valves for—
H.F. AMPLIFICATION AND DETECTION ... 12/6 each.

Mullard L.F. Green Ring Valves for—
L.F. AMPLIFICATION ... 12/6 each.

These Valves only require a 4-volt battery.

Ask your dealer for leaflet M8 and avoid accidents to your valves by using the Mullard Safety Disc, free on request. You can also get Mullard H.F. and L.F. Double Ring Dull Filament Valves.



Mullard

THE MASTER VALVE

Advt.—The Mullard Radio Valve Co., Ltd. (M.W.), Nightingale Works, Nightingale Lane, Balham, S.W.12.

In replying to advertisers, use COUPON on last page

was not soldered to the earth plate but merely threaded through a hole in it and twisted up. The difference was surprising. The more distant stations could not be picked up at all, whilst London, twenty-five miles away, was distinctly audible over a very wide band. Further, the set now became so difficult to operate that in the hands of a beginner it would have caused very serious interference.

Comparative Test Results

This set was next taken to a house where the aerial, though well insulated, is low and badly screened. The earth, however, is a thoroughly good one, consisting of a large zinc bath buried immediately below the suspended wire and connected to the set by a heavy cabled wire. Here it was found that, though range and signal strength were not so good as with the first aerial, tuning was quite sharp and instability was not noticeable. Tests were made with several other aerial-earth systems and the conclusions arrived at were as follows:—

- (1) With a good aerial and a good earth first-rate results are obtained.
- (2) A good aerial in conjunction with a bad earth produces poor results.
- (3) With a bad aerial and a good earth the results are much more satisfactory than with No. 2 arrangement.
- (4) Where both aerial and earth are bad the performances of the set are very poor indeed.

From this we see that most of what is gained by erecting a first-

who through force of circumstances are quite unable to erect an aerial which approaches the ideal for receiving purposes. Sometimes it is impossible to get height

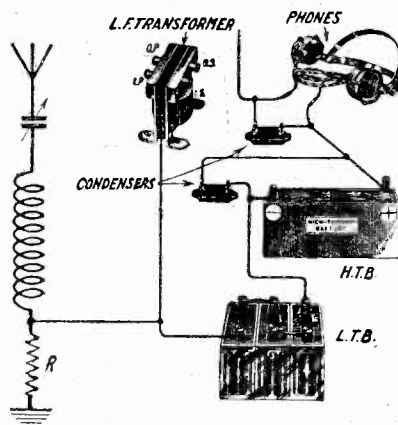

Fig. 4.—A high resistance in the earth lead may make the set unstable.

owing to the presence of telephone or telegraph wires which cross the garden. Sometimes space is so limited that only a short span can be used; again high buildings or tall trees sometimes make it impossible to prevent screening. Used in conjunction with a poor or bad earth connection aerials of all these types will make for indifferent reception; but if the most careful attention is paid both to the earth itself and to the connection between it and the set good reception can be obtained from even a mediocre aerial.

Receiving America

The worst aerial used in the tests referred to above is 60 ft. in length and has an effective height of less than 15 ft. Crossing telephone wires make it impossible to raise either the house end or the free end. The former is attached to the top of a window frame some 15 ft. below the highest point of the roof. At the free end is a 20 ft. mast, the suspended wire passing over a high shrubbery on its way. Buildings and large trees form a screen on either side. Though it belongs to an experimenter it is probably one of the worst aerials in this country. The earth is, however, a thoroughly good one, and with this system it is possible to pick up several American broadcasting stations on any reasonably favourable night with quite a small set. There are other houses in the same neighbourhood with lofty aerials

and carelessly made earths where even large sets never succeed in bringing in WGY or WJZ.

The best Earth to use

I suppose that one of the most commonly used earths is the water pipe. So long as you get hold of the right pipe this usually makes an excellent connection. Frequently however, people make use of the first convenient pipe that they come across without bothering to discover what its function is. If it is of the kind shown in Fig. 5 it will usually answer very well indeed. Here we have a pipe rising directly from the underground main and filled always with a column of water. A lead soldered to it will thus provide the receiving set with a low-resistance earth connection. In Fig. 6 is seen the kind of pipe which is of far less use, as your earth lead may be unduly long. If, therefore, you decide to use a water pipe earth make quite sure that you select an ascending main of the kind shown in Fig. 5. Usually it is quite easy to trace out the pipes, but if you are unable to do so your plumber will tell you which is which. Whilst he is there it would be as well to get him to solder a lead to the pipe, for this is a rather difficult job for the amateur to undertake for himself.

If soldering is not done a portion of the pipe must be well scraped until it is quite bright, when an earth clip should be placed upon it and well tightened up. Though this kind of connection is not quite so good as one that is soldered it

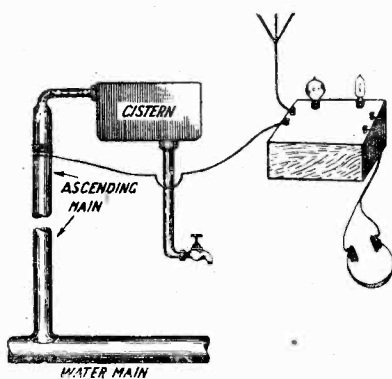

Fig. 5.—An ascending main makes a good earth.

rate aerial may be offset by an inefficient earth, and that even a poor aerial will give quite good working if the earth is made as efficient as possible. This last is a very important point, for there must be thousands of enthusiasts

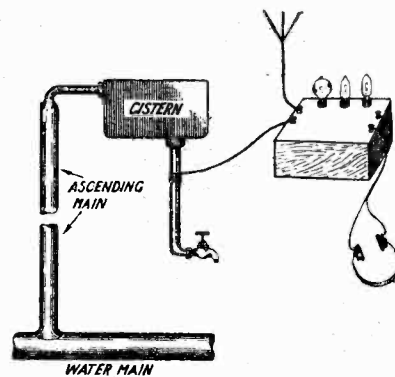

Fig. 6.—This arrangement is often poor.

answers very well as a rule, provided that it is examined from time to time, any dirt or corrosion being cleaned away. A very good home-made connection to a pipe is shown in Fig. 7. When the surface of the pipe has been thoroughly cleaned a brass plate, about 2 in. in

length and rather less in breadth than the diameter of the pipe, is placed as shown in the drawing, the tip of a wedge of metal or of hard wood being inserted between the plate and the surface of the pipe. The wire is then wound on as tightly as possible and twisted up with pliers. The wedge may now be driven in a little way so as to increase the tightness. If later on the wire is found to have slackened a little the joint can be made good at once by giving the wedge a few taps.

A type of earth connection which is far too often seen is that shown in Fig. 8. Here instead of connecting to a water-main the earth lead is joined to a gas-pipe. This is a thoroughly bad practice. Quite apart from the question of actual danger in case the aerial should be struck by lightning

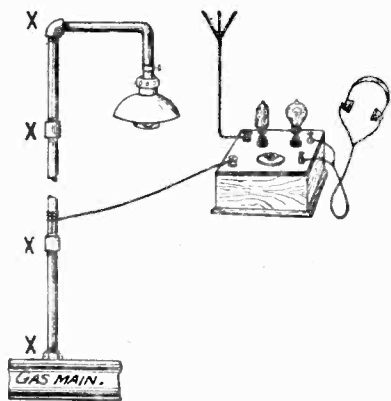

Fig. 8.—A gas-pipe provides a poor earth.

during a thunderstorm, this kind of earth is most unsatisfactory. The joints of a gas-pipe (XX, Fig. 8) are sealed in order to make them gas tight, but the compound used, besides preventing an escape of gas, also offers a very high resistance. Hence a gas-pipe is in nearly every case quite inefficient as an earth connection. I have come across cases in which it was absolutely impossible to obtain any kind of earth connection except a gas-pipe owing to the peculiar situation of the room containing the wireless set. When this kind of thing happens a good way is *not* to make shift with the pipe but to do away with the usual earth connection in a way which will be described later.

If it is possible to make use of either an indoor earth connection to a water pipe or a plate buried in the garden, which of the two is to be preferred? As a rule we may say whichever requires the shorter lead to connect it to the earth terminal of the receiving set. If

there is nothing to choose in this respect I would prefer a plate of some kind buried immediately un-

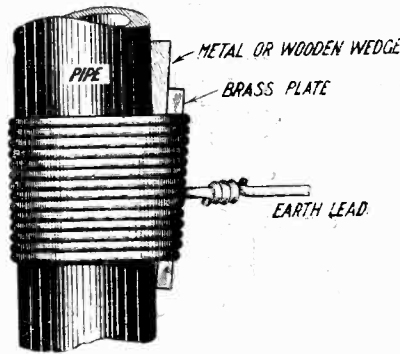

Fig. 7.—How to make a good connection to a water pipe.

der the aerial wires to a water-main. This rule, however, is not infallible, and the best way of finding out which of the two gives better results is to make actual trial of one against the other. Fig. 9 shows the earth connection that I have used now for some considerable time.

An Efficient Earth

It consists of a 7-lb. biscuit tin which is buried 3 ft. or 4 ft. below the surface of the soil, immediately under the suspended aerial wires. The paper with which the tin is covered must of course be washed off first of all. The connection to the set is a length of 7/22 cable, one end of which is unstranded at the point where it enters the earth, each wire being soldered separately to a different place at the top of the tin. If the soil in which the earth is buried is of a light dry nature it is as well to insert an old piece of stove pipe as shown in the drawing. A can of water poured down the pipe every two or three days in dry weather will suffice to keep the earth connection always moist. The dampness of the surrounding soil is one of the most important factors in obtaining an efficient

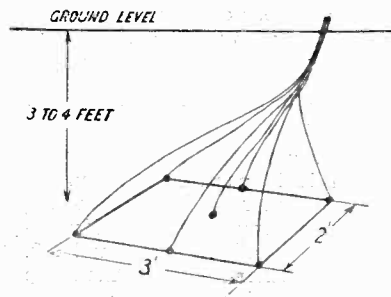

Fig. 10.—A buried earth-plate.

buried earth. If it becomes parched and dry there may be a very high resistance between the metal and the soil. Wet soil, however, makes an excellent low-resistance contact with the metal. In place of the biscuit tin contact an old scullery zinc bath may be used with equally good results. The great thing is to provide a good contact-surface, and to keep the surrounding earth moist. An improvement is to drill two or three very small holes about half-way up each side of the tin or bath. Water poured down the pipe then oozes through these holes, moistening the soil outside as well as inside the tin.

Fig. 10 shows a form of earth-plate which is preferred by some experimenters. This consists of a sheet of zinc about 3 ft. long by 2 ft. wide, the 7/22 connecting cable being unstranded

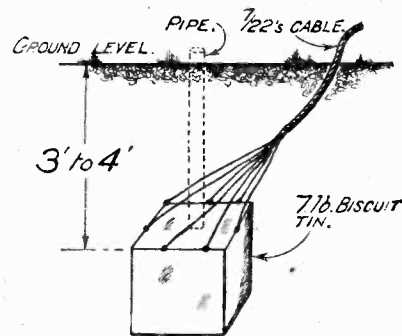

Fig. 9.—A biscuit tin as an earth.

as before and each of its wires soldered to a different portion of the plate. Such a plate should also be buried as nearly as possible below the aerial, and precautions must be taken to ensure that the ground is kept damp.

Keep your earth damp

This may be done in the way shown in Fig. 11. Immediately over the plate an oval ring is made by heaping up the soil into an edge and patting it hard with a spade. Water poured into this ring will form a large puddle which will sink into the soil immediately over the plate. A dressing of cement applied to the inner surface of the surrounding edge will prevent any water from leaking away into places where it can do no good from a wireless point of view.

Another very effective earth is shown in Fig. 12. Here we have a metal pipe 4 ft. or 5 ft. in length, the lower end of which is fitted with a plug of wood. A few small holes are drilled as shown in the drawing in the pipe which is buried so that only a few inches

January, 1925

MODERN WIRELESS

IT'S THE LEAK THAT DOES IT



Patent Pending.
The 'Bretwood' Grid Leak
(Guaranteed)

tunes a carrier wave from the silent point up. The "Bretwood" is recognised by highest experts and experimenters as the only variable and reliable Grid Leak.

If you are not satisfied within 7 days, money will be refunded.

PRICE
3/-
Postage 3d

RADIO IMPROVEMENTS, LTD.
12-18, London News, Maple Street, London. W.

Barcode 159



FOR SECURITY IN YOUR AERIALS

and a thousand purposes where great strength and strain is needed. FLEXIBLE

STEEL WIRE ROPE, Aeroplane Cable made to Government specification to specified breaking strains. PRICES BELOW COST. Orders of 10/- and over carriage paid, otherwise, please add 1/- for postage.

No.	Dia.	Strain.	100 ft.
0	1/16	5 cwt.	4/6
11	5/32	25 cwt.	10/-
52	3/16	35 cwt.	11/-
53	7/32	45 cwt.	12/-
5	1/4	70 cwt.	14/-
7	11/32	100 cwt.	20/-

Strainers for use with above, right and left-hand threads, 9d. each or 8/6 per dozen.
MITH & ELLIS, Ltd. (Dept. 85), 11, Little Britain, E.C.1. Tel.: City 8991.

MAKE YOUR OWN CABINETS.

We supply timber cut accurately to size for amateurs to make their own cabinets. Every part is ready for immediate assembling. Amateurs who use these parts will not have cabinets that look amateurly made, out of square and with jagged edges. Each part is planed smooth, sawn square, and fits accurately.

Prices for Stock Sizes of Cabinets.

Cabinet.	Parts per set.	Cab. made up and polished.
6 x 6	2/-	3/6
9 x 8	3/6	6/6
10 x 9	4/6	8/-
12 x 10	5/6	10/6
14 x 12	7/-	14/-
16 x 12	8/-	16/-

All postage 9d.

Sloping Cabinets 50 per cent. on these prices. Ask for quotations for special sizes. Nothing but the best oak or mahogany is used in making these parts and cabinets.

F. & J. FLETCHER, Ordish Timber Yard, Water Lane, Halifax, Yorks.

YOUR CABINETS.

The original House for hand made and polished Mahogany, Oak and Teak Cabinets to customer's own design. All Timber used in my cabinets is carefully selected and guaranteed THOROUGHLY seasoned.

YOUR PANELS

Finest quality Ebonite to size and fitted 3d. per square in. This ebonite is guaranteed British Made to Post Office Grade "A" Specification, which is the best for wireless purposes.

ANNOUNCEMENT.

Owing to the increasing demand for my specially made cabinets and panels I have extended this department in order to maintain my usual prompt deliveries. Individual attention given to all enquiries.

W. H. AGAR

MANUFACTURER OF TELEPHONE and RADIO APPARATUS.

Tel. L. Wall 3375. 19, WHITECROSS PLACE, WILSON STREET, E.C.2



The
TRUE MUSIC
Concert Grand
— £6.10.0 —
and TMCN-3
Lightweight
Headphones

22/6

THE REWARD OF VIRTUE.

An "infinite capacity for taking pains" is a virtue that has brought us, at all events, a very material reward; for we are so flooded with orders for the TrueMusic Minor that we must, in self-defence, stop advertising it.

We are going to try instead to turn your attention towards the TrueMusic Concert Grand—right at the other end of the scale.

The horn of this magnificent instrument is of electrolytically deposited copper. It is finished in a beautiful tone of nigger brown, with the inside polished and lacquered. It is 30½-in. high, and the resistance is 4000 ohms.

The tone and volume of the Concert Grand are both unequalled. It is a really high-class instrument, and the highest of its class. Its price is only **£6 10 0**.

T.M.C. No. 3 Lightweight Headphones weigh only 6½ ounces. Ventilated ear-caps, balanced magnetic circuits, decently long connections that won't catch your pipe—all show that attention to detail, that "infinite capacity for taking pains" that characterises all T.M.C. products.

LOUD SPEAKERS.

TrueMusic "Minor"	£1 1 0
TrueMusic "Junior"	2 10 0
TrueMusic "Standard"	5 0 0
TrueMusic "Concert Grand"	6 19 0

T.M.C. No. 3 Lightweight Headphones .. £2/6

T M C

The Telephone Manufacturing Co., Ltd., Hollingsworth Works, West Dulwich, S.E.21.

L.P.S. 209.

In replying to advertisers, use COUPON on last page

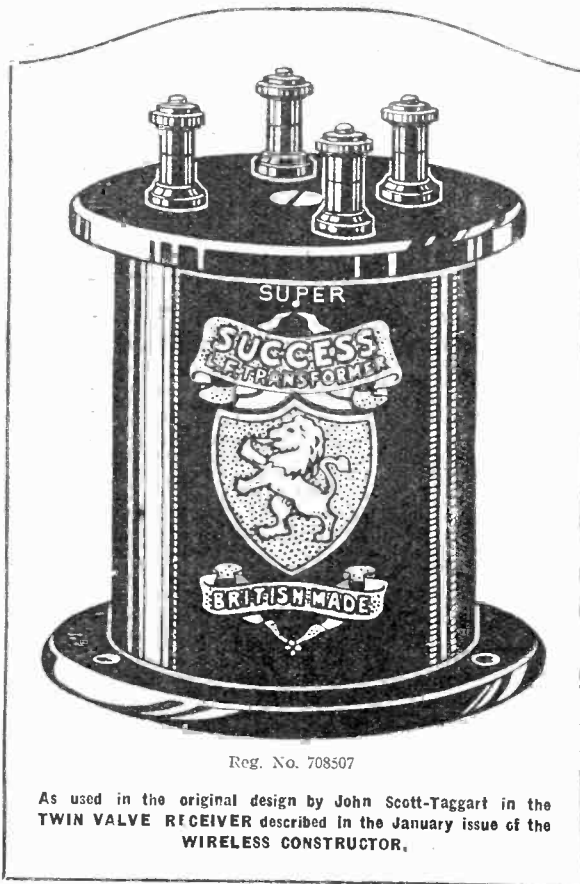

Reg. No. 708507

As used in the original design by John Scott-Taggart in the TWIN VALVE RECEIVER described in the January issue of the WIRELESS CONSTRUCTOR.

THRILLS OF POWER

SUPER SUCCESS LOW-FREQUENCY TRANSFORMER

is not intended for experimenters who are satisfied with the amplification of their present transformers, but rather for those enthusiasts who want something better.

Many months of consistent experiment in design and construction to produce an actual power transformer which will amplify evenly throughout speech and music frequencies, and render truthfully the all-important harmonies of musical tones, has given Radio the SUPER SUCCESS.

The acid test lies not in scientific data however, but in the verdict of your own ears. Put a SUCCESS Transformer in your existing set—that's the real test. Your judgment will agree with that of the expert—a transformer which amplifies to powerful loud speaking.

DESIGNED FOR POWER AMPLIFIERS

The SUPER SUCCESS L.F. TRANSFORMER embodies such features found particularly necessary in power work.

The primary is wound in such a position that minimises the sudden breaks in the magnetic field—a kick-back which has sounded the death-knell of many an amplifier. The turn ratio—a matter of importance—but more vitally so—good wife, evenly wound to a very large number of turns so that the output across the secondary terminals is one of remarkable signal voltage.

THE SUPER SUCCESS (ALL BLACK) IS A POWER TRANSFORMER PRICE 21/-

SUCCESS VERNIER COIL-HOLDER.

A cleverly designed coil-holder. Gives micrometer and quick control, and enables the adjustment of coil coupling up to the razor-sharp point.

As used on the 4-valve T.A.T. Receiver by John Scott-Taggart. PRICE 5/6.

Specifically adapted for behind panel mounting. Occupies the minimum space. Its superiority of design for behind panel mounting over the coil-holders with swinging coils is at once apparent. Supplied with base and brackets ready for mounting.

As illustrated, Price 8/6

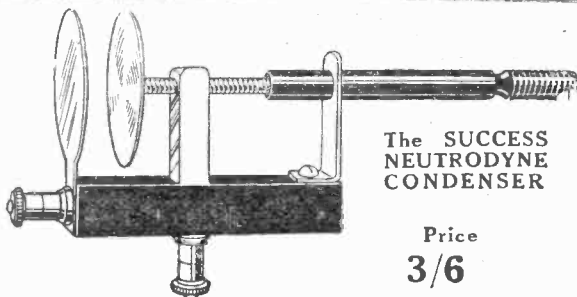
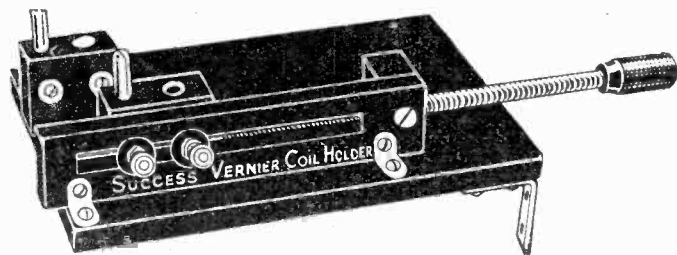

The SUCCESS NEUTRODYNE CONDENSER

Price 3/6

Designed to proved principles and combines mechanical and electrical features particularly suitable for the purpose. Its capacity allows a good margin both at minimum and maximum, and may be used in conjunction with every type of valve with complete satisfaction.



COMPONENTS

Obtainable from all Dealers.

protrude above the surface of the ground. To the top the earth lead is soldered. This form of earth

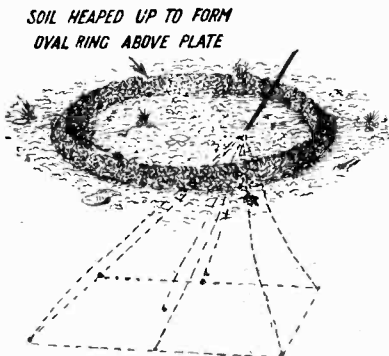

Fig. 11.—How to keep an earth-plate damp.

ensures a good moist connection, since water poured into the pipe gradually leaks away through the small holes moistening the soil all round. The pipe should be of large diameter, say 4 in. or 5 in. so as to provide ample contact surface.

The Counterpoise

I referred a little way back to a difficulty which may occasionally arise where it is quite impossible to obtain an outdoor earth, and a gas-pipe is the only indoor connection available. Should you be so situated it is better to make use of the simplest form of counterpoise, rather than press the gas-pipe into

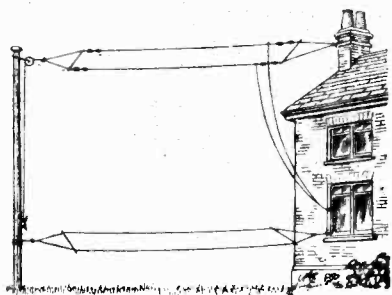

Fig. 14.—A counterpoise earth.

service. Take a coil containing a dozen yards or more of insulated wire—either single flex or bell wire answers admirably—attaching one end of it to the earth terminal and simply throwing it on to the floor below the table on which the set rests. In most cases this simple counterpoise will give good results. This is a most useful tip if one wants to rig up a receiving set quickly for some purpose. Some kind of aerial can always be obtained without much trouble by slinging a wire from the house to

a tree or to another building, but the earth connection nearly always takes some time to plan out and make. By using simply a coil of wire this trouble may be eliminated with a very great saving of time. I have often made use of this handy form of counterpoise when giving demonstrations at lectures and so on.

The Aerial and Earth System

In the aerial and earth system we are actually making use of a condenser of large size, but with a small capacity, as a collector of oscillations. Fig. 13 shows this diagrammatically. With the counterpoise the plates of the condenser are formed as shown in Figs. 14 and 15. It consists simply of a

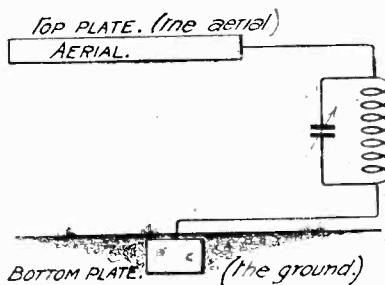

Fig. 13.—Aerial and earth respectively may be regarded as two plates of a condenser.

second set of aerial wires suspended not less than 6 ft. from the ground and insulated just as carefully as the first set. It is important that the counterpoise should contain at least as much wire as the aerial itself. Personally I have found that excellent results are obtainable by using for a counterpoise the copper ribbon which is now sold for making aeriels. In Fig. 14 both aerial and counterpoise are shown with double wires. I have a strong preference for the single wire aerial and my own practice is to make use of one strand of 7/22 cable suspended as high as possible

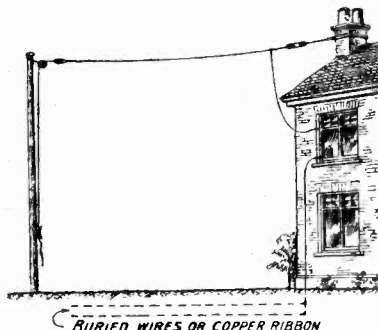

Fig. 16.—A good outdoor earth.

with two good insulators at either end. The counterpoise is formed by a length of 1/2 in. copper ribbon insulated in the same way. The

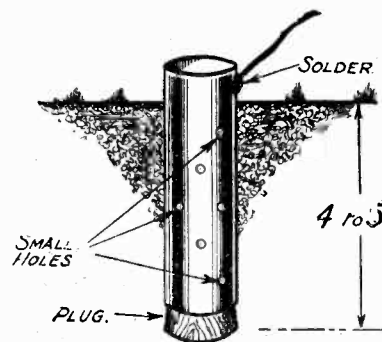

Fig. 12.—A metal pipe as an earth.

lead in from the counterpoise is brought into the house through an insulated tube similar to that used for the aerial lead in.

A good compromise between the earth and counterpoise can be made by burying lengths of wire or of copper ribbon immediately under the aerial as shown in Fig. 16. These need not be more than a few inches below the surface of the soil. In damp weather a perfect earth connection is assured, whilst should the soil dry up in summer time a counterpoise effect is obtainable. An earth of this kind is practically independent of drought or rainy weather.

In conclusion we have seen that

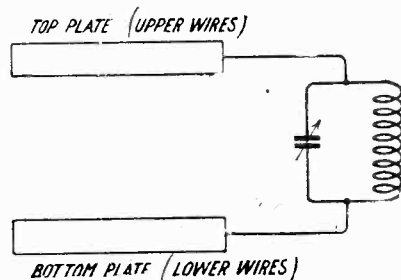
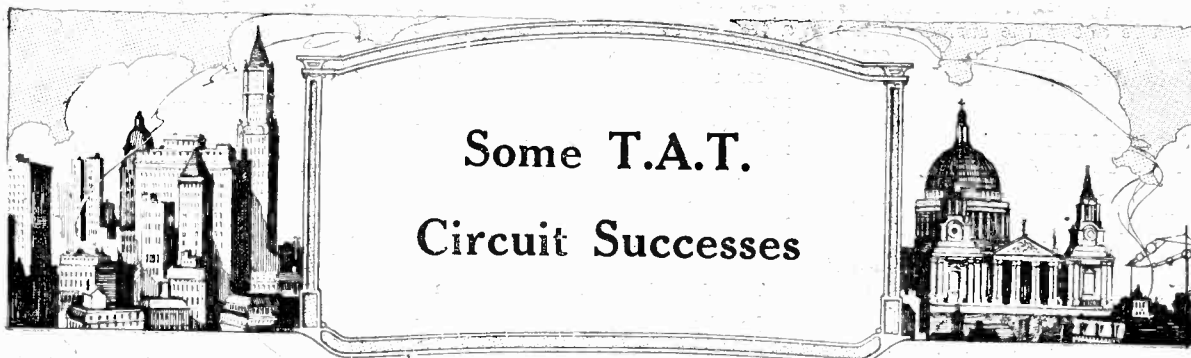

Fig. 15.—Showing how an aerial and counterpoise act as a condenser.

even the best aerial may have its efficiency ruined if it is used in conjunction with a bad earth, whilst a poor aerial may be made to give quite good results if the earth connection is made thoroughly efficient. Outdoor earths are usually rather better than connections made to a water pipe, provided that care is taken to place them beneath the suspended wires and to keep the soil in which they are situated damp. An indoor counterpoise is to be preferred to a gas-pipe connection



Some T.A.T. Circuit Successes

Readers' results are here given with circuits advocated by the Editor in his article on the T.A.T. System in the November Issue.

No. 14 Circuit.

SIR,—I am grateful to you for such a circuit as given in November MODERN WIRELESS—namely, the T.A.T. system. Radio Press circuits are my hobby and I try a great many, but must give the T.A.T. system first place. ST 100 was very good, also the All-Concert and Grebe. Although not knowing anything about wireless when I started, the instructions and explanations were so exact that now at the first glance at a circuit I know what kind it is and I now thank you for the abundant information. The T.A.T. circuit I made up was Fig. 14 4 H.F. Det. and one stage of L.F., but instead of reaction on the aerial I applied it to the last tuned anode. I get all the B.B.C. stations at loud-speaker and the relay stations at 'phone strength, which is very good here. I have had nine Continental stations, but not understanding the language I cannot tell all of them. Now all these stations were got with a very poor aerial, about 30 ft. high and 3 ft. from roof of house. With an inside aerial in another part of the town I got most of the B.B.C. stations and Brussels, but there were several listening in on the set and I had not very much chance to try it out there.

Thanking you for your publications.—Yours truly,

A. MYLES.

Stirling.

P.S.—The nine Continental stations were received between 250–550 metres.

A T.A.T. Circuit.

SIR,—During last week I converted a five-valve set having two tuned anodes to a T.A.T., with reaction on the aerial. The set is situated close to Dublin and has a first-class aerial and earth. The performance was good. In the following, by loud-speaker strengths I mean loud enough for eight or nine people to hear comfortably

in a large room. Bournemouth, Aberdeen, Belfast, Newcastle, Chelmsford and sundry German stations only required one stage of note magnification for loud-speaker strength. All the B.B.C. stations were successfully tuned in except Edinburgh and Plymouth. As I had only one evening with the set, I did not have time to try as much as I would have liked. The circuit was exceptionally easy to tune and reasonably selective.

I think that the conversion was well worth while, although the results were, perhaps, not quite so good; the simplicity of operation well made up for it. I, personally, shall never use two adjacent stages of tuned anode again. I congratulate you.—Yours truly,

A. S. C. HILL.

Hoolwich.

No. 12 Circuit.

SIR,—Your articles on H.F. amplification have been very interesting to me, so much so, that I decided to alter one of my tuned anode three-valve circuits into two H.F.'s., Detector and one stage L.F. This I completed about three weeks ago. The set is as follows:—

No. 1.—H.F. square choke of 200 turns, 28 enamelled wire. M.O. valve 4 volts

No. 2.—H.F. tuned coil with .0003 condenser. M.O. valve 4 volts.

No. 3.—Detector with reaction. Edison valve 4 volts.

No. 4.—Note magnifier (L.F.), not power valve. M.O. valve 4 volts.

I may say here that I had to add reaction in order to make it oscillate, the set being so stable. When completed I connected it to my aerial and the first thing I picked up was an amateur at Newbury; after this I got down to real business, tuned in 2LO at good L.S. strength, next Bournemouth and Newcastle came in at the same strength. This surprised

me very much. I then tried Cardiff and Glasgow; both of these stations could be heard at good L.S. strength. The next thing I thought I would try it on America, after trying another four-valve set of 1 H.F.—D.—2 L.F.'s. conditions being very bad. With set No. 2 I could not pick up a single carrier wave. Morse and atmospherics were appalling and I could not bear the telephones on. I then tried the T.A.T. set, and to my surprise I picked up quite a number of carrier waves. I eventually tuned in WGY and heard speech quite plainly.

This I think is clear evidence that two stages are better than one. I picked up two amateurs below 130 metres. It was as stable here as on 300 to 500 metres.

Wishing you every success.—Yours truly,

E. E. MORLING.

Hampton Wick.

No. 12 Circuit.

SIR,—As I stated in my last letter, I am writing to you to send you a further report on the most excellent T.A.T. receiver, circuit No. 12, with 1 L.F. added (2 H.F. Det & 1 L.F.). In my last letter, I said I had not sat up for America. I have listened for America on four occasions since then and every time with great success.

The following are the stations which I received:—*KDKA (326 metres), KFCK, *KGO, KYW, *WBZ, *WEAF, WGN, *WGY, *WHAZ, WNYC, WJZ, *WOO.

Those marked * at loud speaker strength when using a L.F. amplifier added, making 2 H.F. Det. and 2 L.F.

In my last reports I had received six amateurs, one being French. I have now received 35 different amateur stations, including three or four French or Dutch.

Wishing T.A.T. sets and Radio Press every success.—Yours truly,

B. GRAY.

Dunadry, Co. Antrim, Ireland.



A LOUD-SPEAKER WITHOUT DISTORTION

One of the most natural tone Loud-Speakers on the market, and worked in conjunction with our "BIG BEN" 3-Valve Set the results are perfect. It has no Trumpet. It fits in any corner of the room without being noticed. The retail price in Mahogany or Oak is £6 10 0.

The "BIG BEN" 3-Valve Set complete with 1 B.T.H. "B6" Power Valve, 2 B.T.H. "B5" Valves, 1 100v. H.T. Battery, 1 4v. 80 amp. Accumulator, 1 pr. Siemens' Phones, Aerial, Insulators and "CELESTION" Loud-Speaker, retail price £28 7 0.

Arrange a demonstration at your local Dealer's. If he cannot supply, instruct him to write to us, or write direct to:—

STOCKALL, MARPLES & CO. (1912) Ltd.
6/10, CLERKENWELL ROAD, E.C.1.

Telephone: Clerkenwell 6345/6. Telegrams: Stockalls, Smiths, London.

The FAMOUS FORMO SHROUDED



L. F. TRANSFORMER

WORLD RENOWNED FOR ITS CONSISTENT HIGH QUALITY & FINE PERFORMANCE
PRICE 18/-



THE NOVELTY OF THE SEASON
THE FORMO PORTABLE AERIAL

This aerial can be erected or taken down in a few moments, and may be erected in or out of doors, on a car, on a punt, or any other desired position. Hooks are provided for its attachment, and it is fitted with insulators and anchors, and a terminal for the lead-in wire. Minimises Static. PRICE 7/6.

THE FORMO COMPANY

(Arthur Preen & Co., Ltd.)
Contractors to the Admiralty, War Office, India Office, Air Ministry and Post Office.

Chief Office and Works: CROWN WORKS, CRICKLEWOOD LANE, N.W. 2.
Scottish Branch: 22, York Place, Edinburgh. And at Birmingham, Manchester, Newcastle, Bournemouth.
Sole Agents for Bristol and Cardiff: The Sloan Electrical Co., Temple Street, Bristol.

TUNING COILS

You should use with
SQUARE LAW CONDENSERS

You are all fitting Square Law Condensers to your receivers—but remember when purchasing your tuning coils that the efficient working of the straight wavelength curve requires a coil of extremely low self-capacity.

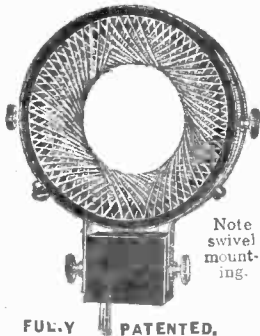

Note swivel mounting.

FULLY PATENTED.

Use, therefore, the **DIAMOND SUNFLOWER** coils of low self-capacity, low H.F. resistance, maximum transference of energy and consequently maximum signal strength, sharper tuning and selectivity, follow the fitting of "Diamond Sunflower" Coils.

If your receiver suffers from flat tuning, substitute Diamond Sunflower Coils and note how sharp the tuning becomes. Diamond Sunflower Coils give razor-sharp tuning.



PLUG-IN COILS

They are obtainable from all dealers or direct. Prices and wavelength chart appears in our advertisement in the November issue.

DIAMOND WIRELESS, LTD., 184a, OXFORD STREET, LONDON, W.1.
Telephone: Museum 1380. Entrance Gt. Titchfield Street.

(Barclays 498)

In replying to advertisers, use **COUPON** on last page

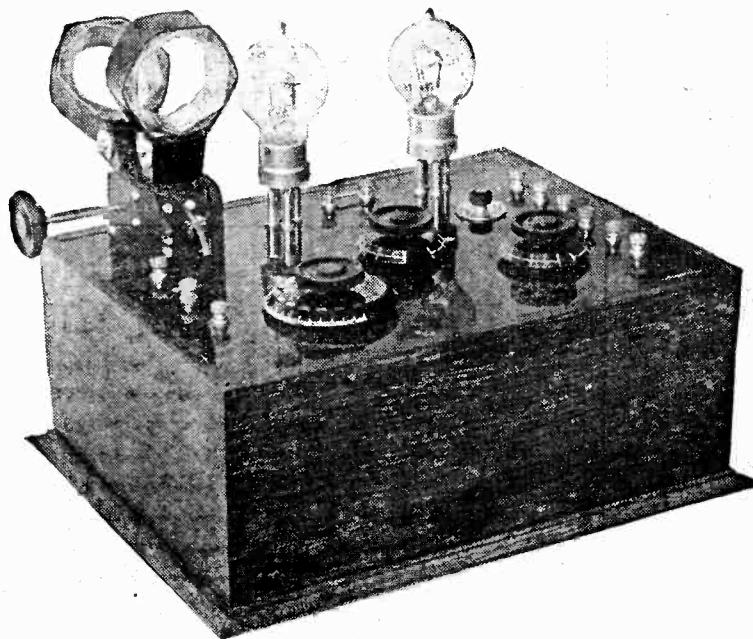

Fig. 1.—The layout gives a neat and handsome appearance.

THE receiver illustrated is one of extreme simplicity to construct, in that it is assembled from bought parts, no making of coils or other components being called for, thus allowing the constructor to devote the whole of his attention to the building of the receiver itself.

The circuit employed is a straight valve detector, followed by a special arrangement of low-frequency amplification similar to that incorporated in a receiver described by Mr. Herbert K. Simpson in Vol. 3, No. 18, of *Wireless Weekly*. Reaction is used in the receiver in the ordinary way by the electromagnetic coupling of two coils.

Oscillation

When using a receiver of this type care must be taken in its operation in order to avoid energising the aerial, thereby causing considerable interference to neighbours through making the receiver oscillate. These remarks apply not merely to the set under description but also to any other receiver in which reaction is applied to the aerial circuit, a point which, judging from the interference experienced in South London through oscillating receivers, is overlooked by many listeners.

A photograph of the set is given in Fig. 1 in such a position that the disposition of the components upon the panel may be seen. The three terminals on the left, reading from the top downwards, are the aerial terminal, including constant aerial tuning, a second aerial terminal excluding constant aerial

tuning, and the third is the earth terminal.

On the right-hand side of the panel, reading from the top downwards, are the two telephone terminals, the H.T. terminals and L.T. terminals, whilst at the back of the panel may be seen two terminals for grid cells when required.

Considerations in Design

In designing this two-valve receiver it was intended to make the operation of tuning as easy as possible without any loss in efficiency; and with this objective in view the circuit chosen was a single-valve reaction arrangement, followed by a single stage of low-frequency amplification in order that not more than one condenser need be adjusted; switching, with the extra wiring it involves, was also eliminated to maintain the general simplicity of the receiver. To allow the use of either bright or dull-emitter valves, suitable fila-

An Improved Two-Valve Receiver

By STANLEY G. RATTEE,

Member I.R.E., Staff Editor.

ment resistances are incorporated, and so far as results are concerned there is nothing to choose between the two types, in that the set will give easy oscillation and purity of signals with both. In order that definite instructions may be given with regard to coil sizes, constant aerial tuning is used, but in those cases where readers prefer not to use this form of tuning, the middle terminal of the three on the left hand of the panel permits the aerial being connected directly to the coil.

Materials and Components

In conformity with the usual practice and for the guidance of those readers who wish the information, the names of manufacturers of the components incorporated in this receiver are given in the following list, and though there is, in fact, no obligation in the choice of components to obtain results similar to those possible with the receiver illustrated, the values given must be strictly adhered to, in that they have been arrived at after considerable experiment, and any departure from them may quite conceivably cause the finished receiver to give either poor results or none at all.

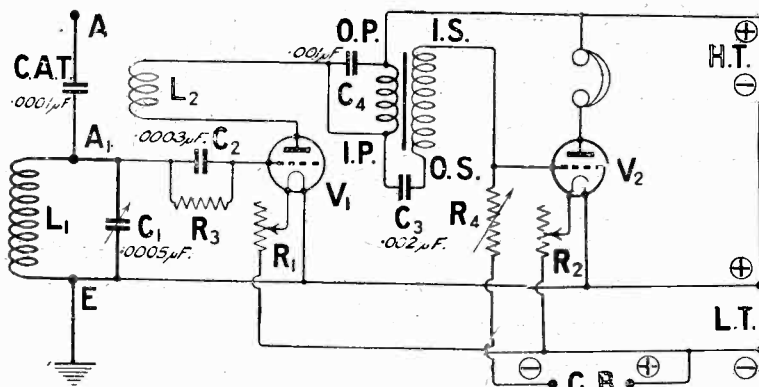

Fig. 2.—The theoretical circuit of the receiver.

A unique 2-Valve Receiver, incorporating a little used, but nevertheless excellent modification of low-frequency amplification.

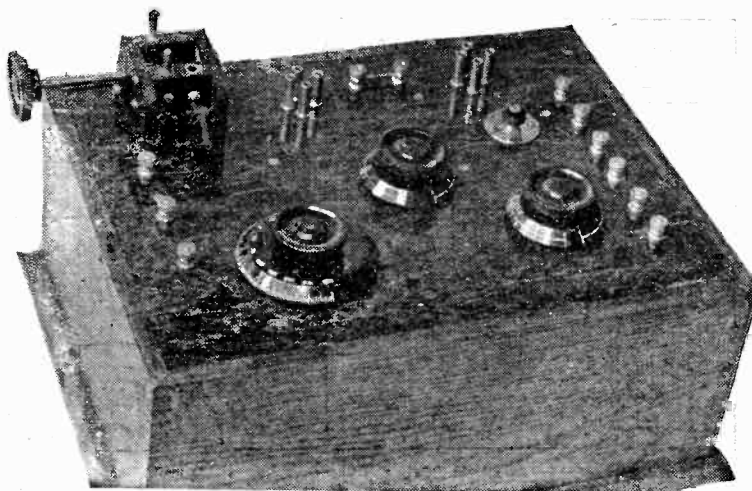

Fig. 3.—With coils and valves removed, the disposition of the components is seen.

- 1 Ebonite panel measuring 9 in. by 12 in. by $\frac{3}{16}$ in. (Radion).
 - 1 Variable square-law condenser of .0005 μ F. capacity (Jackson Bros.).
 - 1 Two-coil holder (Polar).
 - 2 Dual rheostats (McMichael).
 - 1 Grid condenser of .0003 μ F capacity (Dubilier).
 - 1 Grid-leak of 2 megohms (Dubilier).
 - 1 Fixed condenser of .0001 μ F capacity (Dubilier).
 - 1 Similar condenser of .001 μ F capacity (Dubilier).
 - 1 Similar condenser of .002 μ F capacity (Dubilier).
 - 1 Low-frequency transformer (Max-Amp. Peto-Scott).
 - 11 Brass terminals.
 - 1 Watmel variable grid-leak .5 to 5 megohms.
 - 2 Valve sockets, or alternatively 8 valve pins.
- Set of plug-in coils for the wavelengths desired.
Quantity of connecting wire.

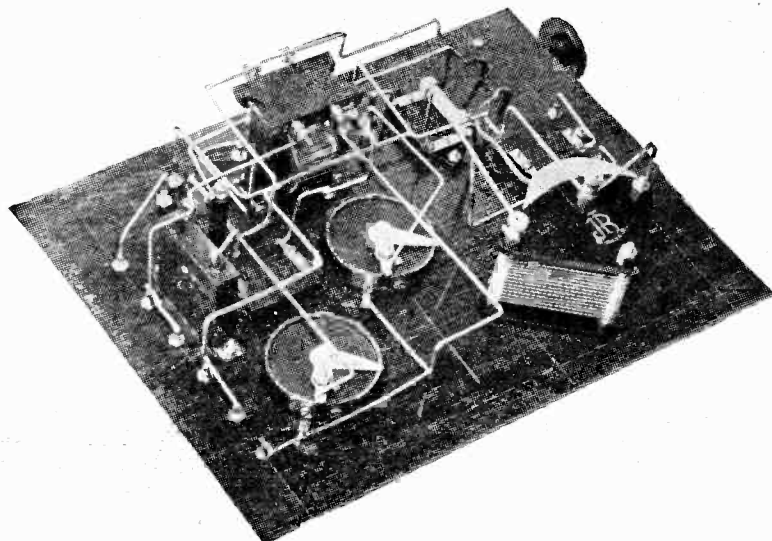

Fig. 4.—A helpful plan view of the wiring.

Coils to Use

The coils required for this receiver are, in the case of the lower broadcast band, using constant aerial tuning, a No. 50 for aerial tuning, with a No. 75 for reaction; for the higher band a No. 75 in the aerial circuit, with a No. 75 for reaction. For the same wavelength range without constant aerial tuning coils No. 35 or 50 will be required for aerial tuning, with a No. 50 or 75 for reaction. For the reception of 5XX and Radio Paris without C.A.T., a No. 150 for the aerial, with a No. 200 as reaction coil will be necessary. The reception of the Eiffel Tower may also be tried, using a No. 250 in the aerial socket, with a No. 250 or 300 for reaction.

The Panel

In connection with ebonite, readers are reminded that there are

certain manufacturers who supply guaranteed material free from surface leakage and possessing a highly polished finish. On the other hand, there are makes of ebonite which do not bear this guarantee, and in cases where this material is used, after the panel has been drilled in accordance with the panel layout, the glossy finish on both sides should be removed by means of fine emery-paper, as it is very often found that this glossy surface offers poor insulation between the different components, resulting in the set giving feeble results and a noisy background when working. The panel will, after this rubbing treatment, present a somewhat shabby appearance, but the application of a little oil rubbed in with a soft rag will soon restore the deep black the panel originally possessed. In those cases where guaranteed ebonite is used this precaution of removing the surface skin is, of course, unnecessary.

The Circuit

The circuit of the receiver is given in the theoretical circuit diagram, wherein will be seen the transformer connections. This arrangement with the transformer chosen gives very pure amplification, though it must not be inferred from this that the results will be as good with every make of transformer, and it is suggested that both this and the usual arrangement be tried before finally completing the receiver. Apart from the L.F. valve connections, the remainder of the circuit is perfectly straightforward.

The coil L_1 is the aerial tuning inductance across which is shunted the .0005 μ F variable condenser.

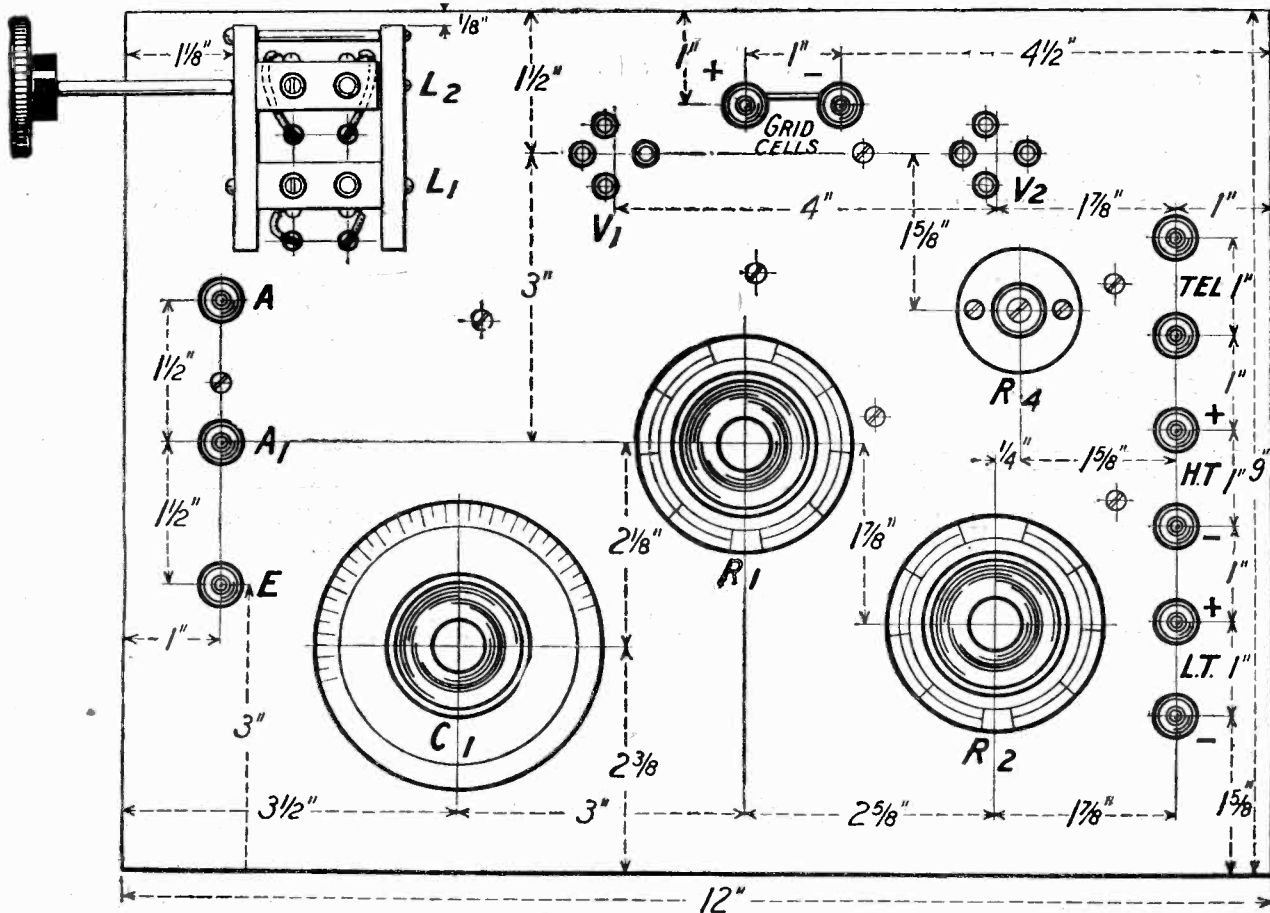

Fig. 5.—Front of panel layout and drilling diagram. Blue Print No. 86A.

C₂ and R₃ are the grid condenser and leak respectively, whilst R₁ and R₂ are the filament resistances. L₂ is the reaction coil connected between the plate of the detector valve and the primary of the low-frequency transformer. This latter it will be seen is shunted by a fixed condenser of .001 μF capacity. It will be further observed that the secondary of the transformer is connected to the primary through a condenser of .002 μF value, and though this arrangement works well with a number of transformers chosen, it is suggested that experimenters try various values for this condenser, such as .001 μF and .0005 μF. The resistance R₄ is of the variable grid-leak type, giving a variation from 1/2 to 5 megohms, and is used in order that the electrons collecting on the grid of the low-frequency valve may leak back to the filament. This arrangement of connections gives a decided improvement in the purity of signals and is one which was recommended by Mr Scott-Taggart in his Valve Notes appearing in *Wireless Weekly*, dated April 23 of this year. The adjustment of the variable resistance

varies with different makes of valves, but once the best adjustment is found for any particular valve no further variation is called for as long as the H.T. value is kept constant.

The Wiring

The system of wiring may be observed from these photographs showing the underside of the panel, whilst for working purposes the various connections may be followed from the wiring diagram. Connections should preferably be soldered and all leads kept as short as possible. Though the use of stiff bare wire is advocated, it would seem that many readers experience difficulty in handling this material, and in cases where such difficulty is anticipated soft wire and Systoflex may, of course, be used, so long as reasonable care is taken in spacing the leads and in keeping them as short as circumstances will permit.

Operating the Receiver

After the wiring has been completed, connect the accumulator to the terminals indicated in the panel

layout, and after turning the filament resistances to the "off" position, insert the valves and test the lighting circuit at this stage by slowly turning the filament rheostats, noting whether the brilliancy of the valve filaments is consistent with the amount of resistance in circuit. Assuming this test to be satisfactory, connect the H.T. battery. If it is desired to test the receiver during the hours of broadcasting, then reception should be tried on wavelengths other than those upon which the majority of listeners will be concentrated (coil No. 100 in the aerial socket, with a No. 100 for reaction, for instance). After inserting the coils, the next operation is to short-circuit the grid cell terminals. Turn the coils at right angles to each other, and then light the valves to a suitable degree of brilliancy, not forgetting, of course, the aerial and earth connections.

At this stage the variable condenser should be slowly turned, at the same time bringing the moving coil nearer to the fixed, avoiding whilst so doing the point of oscillation. So long as the oscillating

"ELLA"
BATTERY CHARGERS
They work from a lampholder

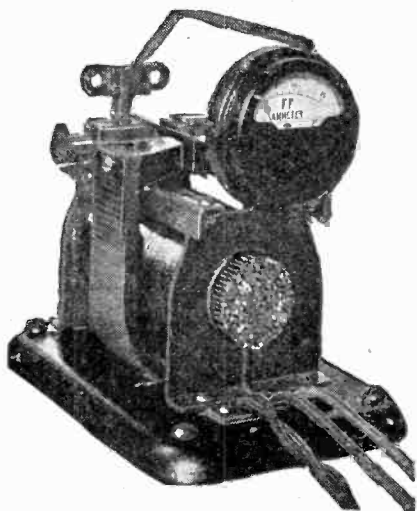

A.C. Model.

Output 5/10 amps. 9 volts. Complete with Pole Indicating Ammeter and all connecting leads and adapter £6 6 0

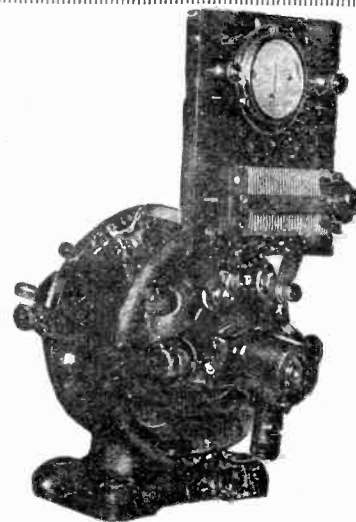

D.C. Model.

Output 5 amps. 9 volts. Machine only £5 12s. 6d. With Switchboard and Pole Indicating Ammeter and Regulating Resistance as illustrated - £6 15 0

There is an "ELLA" Battery Charger for every supply voltage.
BATTERIES charged at home have much longer life and give better service than when charged outside.
"ELLA" Battery chargers save their cost many times over.

Send for descriptive leaflet. Trade Supplied.

LIONEL ROBINSON & CO. 3a, Staple Inn, London, W.C.2.

'Phone: Holborn 6323 (Two Lines).

Listeners-in
demand a perfect
LOUD SPEAKER
- and they get it in the



Standard Model: 120 ohms, £4 15 0; 2,000 ohms, £5 0 0;
4,000 ohms, £5 10 0.

Junior (2,000 ohms) £2 15. Tom Tit (2,000 ohms) £1 10.
No. 1 Crystalline Enamel. No. 2 Black Satin Enamel
Tom Tit in No. 1 finish only.

Folder o.s. Request.

C.A. Vandervell & Co., Ltd.
ACTON VALE, LONDON, W. 3.
Members of the N.A.R.M.

In replying to advertisers, use COUPON on last page



**Experts
who understand
quickly appreciate
quality!**



*Every "Powquij" Transformer
is tested on Aerial and is
Guaranteed for 12 months.*

"POWQUIP"
Transformer
Standard Type.
Price 14/6

The
POWER EQUIPMENT
COMPANY LIMITED

KINGSBURY WORKS, THE HYDE, HENDON, N.W.9.

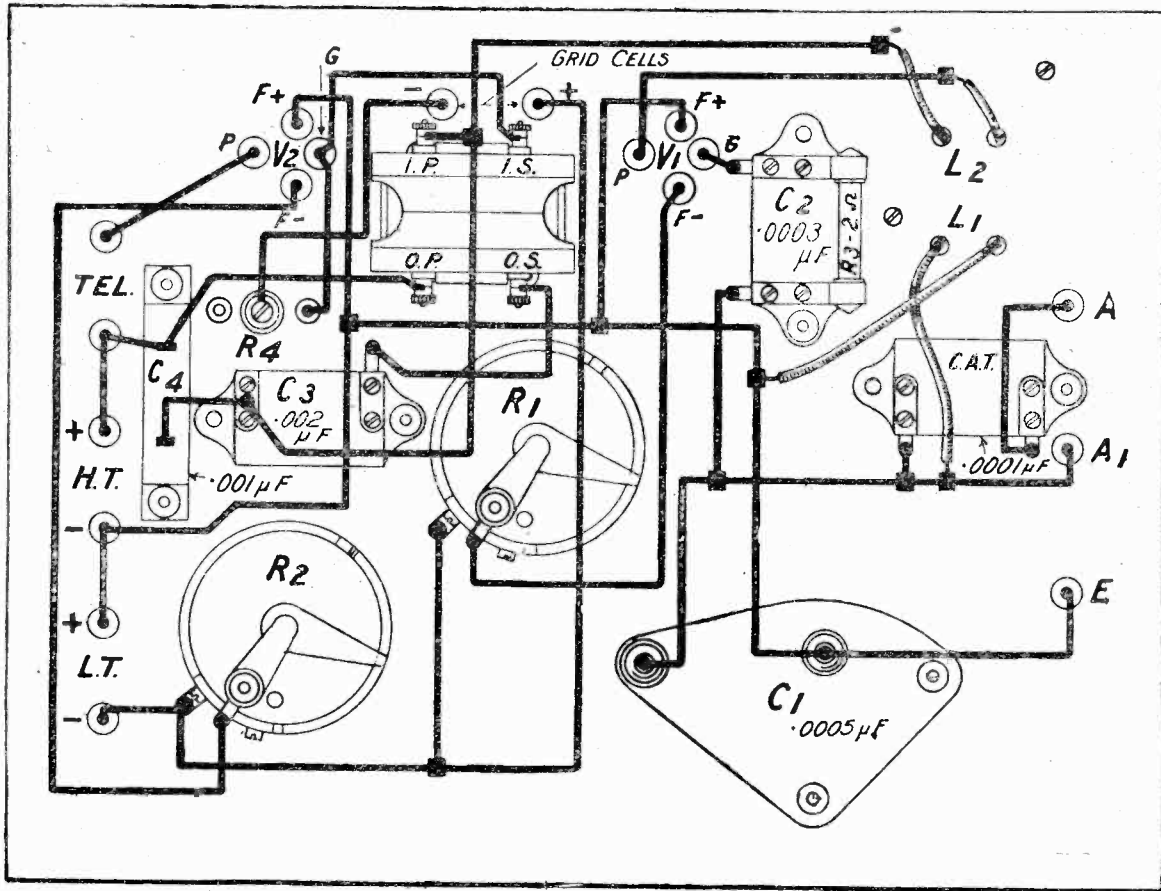

Fig. 6.—Back of panel wiring diagram. Blue Print No. 86B.

condition is approached with due care, the point of oscillation will make itself heard by a "cluck" in the telephones, upon which the moving coil should be slightly withdrawn from the fixed and the tuning condenser again adjusted.

Should the set fail to give any tendency towards oscillation, then this fact indicates that the reaction coil is coupled in a reverse manner to the aerial coil, and the connections thereto should be changed over.

B.B.C. Wavelength.

For the reception of the B.B.C. stations the same operations should be gone through, bearing in mind that any alteration in the position of the reaction coil necessitates further tuning upon the variable condenser. Care should be taken to see that the set does not oscillate.

Whilst telephony signals are being received the variable resistance, connected between the grid of the second valve and the negative of the grid cells or L.T. battery, as the case may be, should be adjusted to give the purest results, the purpose of this resistance being to prevent an accumulation of electrons on the grid of the low-frequency valve.

Grid Cells

In those cases where readers decide to use dull-emitter valves with this receiver, it is advised that a grid biasing battery be incorporated, two separate terminals

being provided for this purpose. Usually a battery of 4½ volts tapped at 1½, 3 and 4½ volts made up from flash-lamp cells will be found sufficient for grid bias, depending, of course, on the value of H.T. used, the

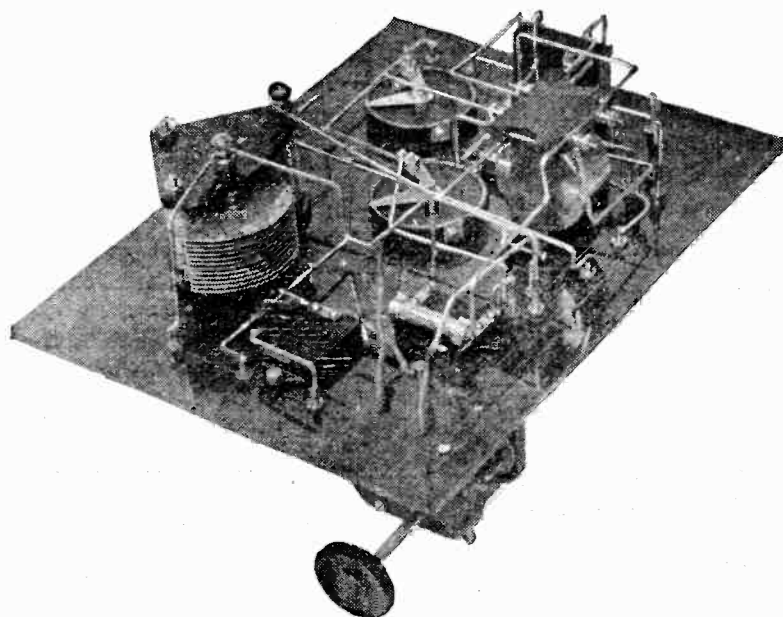

Fig. 7.—This photograph gives a good idea of the elevation of the wiring.

inclusion of which will eliminate that gruff, throaty speech which is sometimes associated with dull-emitter valves when used as low-frequency amplifiers. In the event of the battery not being used, or should the cells become exhausted through deterioration, then the two terminals across which the battery would normally be connected should be joined together by a piece of wire.

Test Report

The receiver as illustrated was tested for the first time during the afternoon of December 6, when, using both constant aerial tuning and the usual method with the aerial connected direct to the grid coil, Cardiff, Birmingham, Bournemouth, and Newcastle were received at good telephone strength during the daylight hours; Radio-Paris was also heard transmitting news during daylight. Later, tests were made during darkness, when Chelmsford and Glasgow were also received in addition to the previously-mentioned stations. London, though received at deafening strength, was not regarded as a serious test. These receptions were made in S.E. London upon an indoor aerial arranged round three sides of an average-size room; and for those readers who are desirous of building a two-valve receiver which demands neither skill in construction nor expert operation, then the set which has been described is one which such readers would do well to build.

As a matter of extreme interest, the author would be glad to hear from readers who construct this or any other of his sets, as the results obtainable in various parts of the country are a valuable indication of what a particular design of receiver is actually capable of accomplishing.

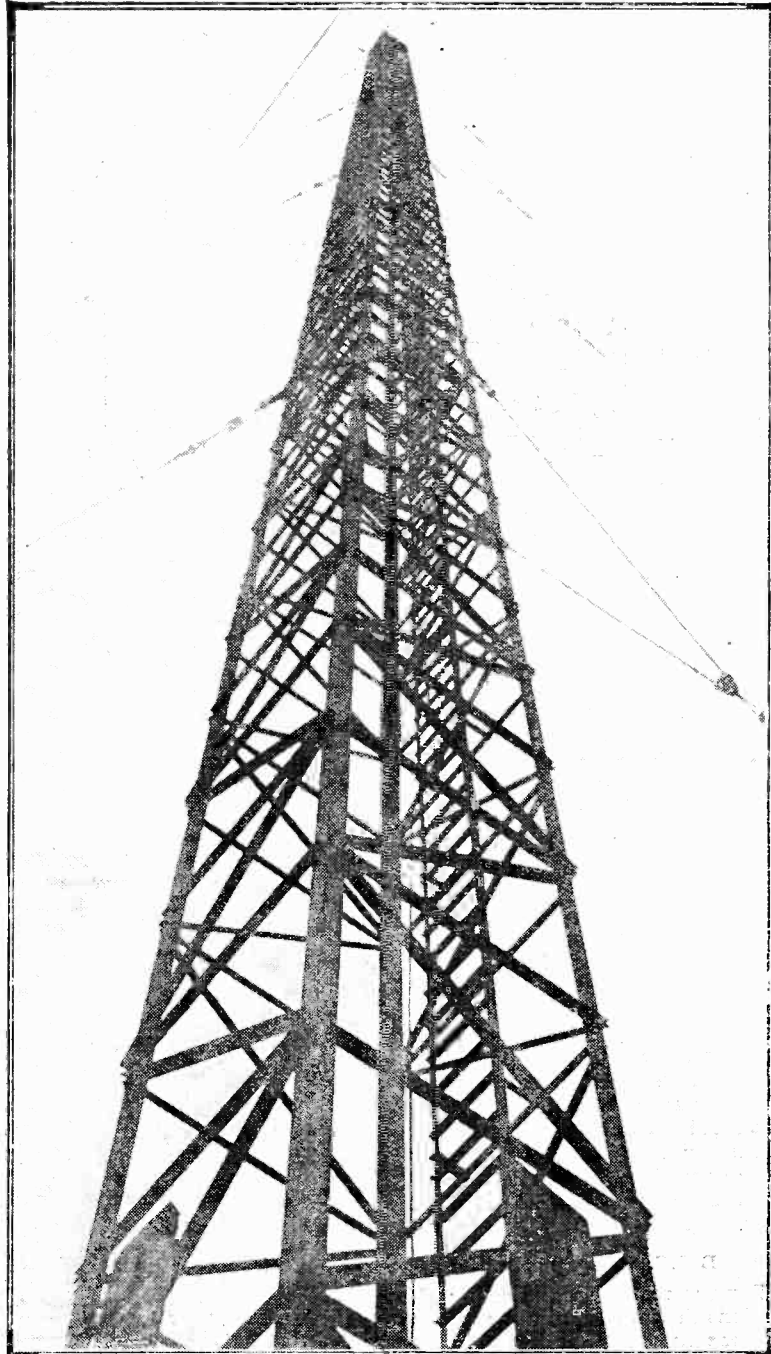

The huge mast seen in the photograph was used to support the aerial at an exhibition in Berlin.

TECHNICAL STAFF REQUIRED

The rapid development of Radio Press, Limited, is accompanied by the need for further technical staff.

There are vacancies for young men between 16 and 30 who are keen and accurate and with a good general knowledge of wireless.

Applications by letter should be addressed, at once, to the Managing Director, Radio Press, Ltd.

All communications are treated as strictly confidential.

PHOTOGRAPHS.

The original photographic prints corresponding to illustrations of Radio Press Sets (including views of the wiring) may be obtained from Radio Press, Ltd, price 2s. 3d. each, post free. These photographs are perfect reproductions and every detail is clearly visible. The name of the article and figure number should be quoted when ordering.

The COLVERN NEUTRODYNE CONDENSER

The present popularity of receivers employing the Neutrodyne principle finds us with a neatly designed instrument with constructional and electrical features specifically for this purpose. Similar in design to the COLVERN General Purpose Vernier which is already well-known—the COLVERN NEUTRODYNE represents utmost efficiency at a moderate price.

Tested by an eminent physicist—who found the COLVERN NEUTRODYNE CONDENSER entirely satisfactory for neutralising valve capacity—it has an extremely low minimum, much lower than can be required, and is operated by a continuous rotary motion up to an ample maximum.

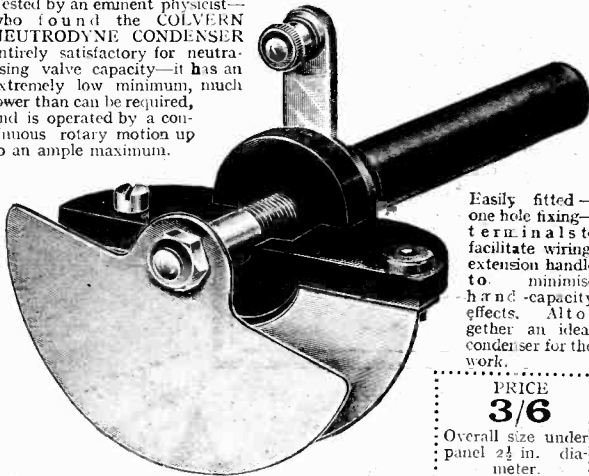

Easily fitted—
one hole fixing—
terminals to
facilitate wiring,
extension handle
to minimise
hand-capacity
effects. Alto-
gether an ideal
condenser for the
work.

PRICE
3/6

Overall size under
panel 2 1/2 in. dia-
meter.

Fit one COLVERN GENERAL PURPOSE VERNIER to every large tuning condenser. Gives much higher efficiency than the vernier in association with a main condenser. The COLVERN persuades the utmost power and gives increased selectivity—at a very moderate price 2/6.

If your dealer cannot supply, kindly send his name and address when ordering.

COLLINSON'S PRECISION SCREW Co. Ltd.
Macdonald Rd., Walthamstow, London, E. 17. Tel.: WAL 537

Barcode 461.

“UTILITY”

NO CAPACITY

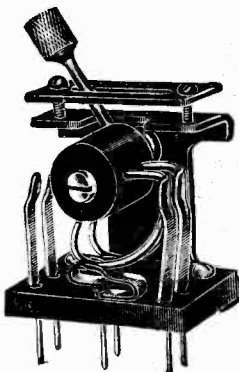

WM. 147/2.

LEVER PATTERN.		each
No. WM 147/1	(1 Pole C.O.)	4/6
No. WM 147/2	(2 „ C.O.)	5/-
No. WM 147/3	(3 „ C.O.)	6/-
No. WM 147/4	(4 „ C.O.)	7/6
No. WM 147/5	(5 „ C.O.)	10/-
No. WM 147/6	(6 „ C.O.)	10/-

KNOB PATTERN.		each
No. WM 130/1	(1 Pole C.O.)	3/9
No. WM 130/2	(2 „ C.O.)	4/-
No. WM 130/3	(3 „ C.O.)	5/-
No. WM 130/4	(4 „ C.O.)	6/-
No. WM 130/5	(5 „ C.O.)	7/-
No. WM 130/6	(6 „ C.O.)	8/-

Black Bronzed.

Lever type nickel plated 6d. each extra.

WILKINS & WRIGHT, LTD.,
Utility Works, Kenyon Street,
BIRMINGHAM.

SWITCHES

Royal Palace,
WINDSOR.

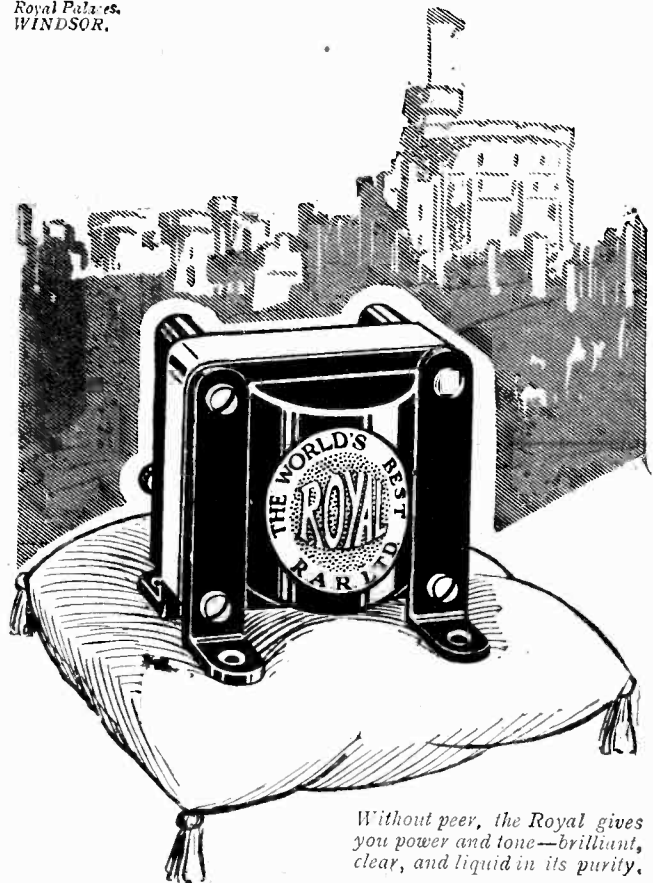

Without peer, the Royal gives you power and tone—brilliant, clear, and liquid in its purity.

If it were within your means to test for yourself the many types of low-frequency transformers would you not choose that one which proved itself of super excellence? An experiment such as we suggest is costly and unnecessary. Manufacturers of Sets Aristocratic have conducted these tests to exhaustion and now they standardize on

The “Royal” LOW-FREQUENCY SUPER TRANSFORMER

Price £1 0 0

FOLLOW THE ADVICE OF TECHNICAL AND MANUFACTURING AUTHORITY—IT IS THE SHORTEST ROUTE

AN OFFER

We are so confident of the supreme quality of the “Royal” Low Frequency Super Transformer that we are willing for you to test it against ANY other on the strict understanding that we will refund the purchase cost on return to us within 14 days post paid.

FULLY GUARANTEED.

R. A. ROTHERMEL, LTD.

MANUFACTURERS & SUPPLIERS OF ALL KINDS OF RADIO AND WIRELESS APPARATUS

24 & 26, MADDOX ST., LONDON, W.1.

Phones: MAYFAIR 578 & 579.

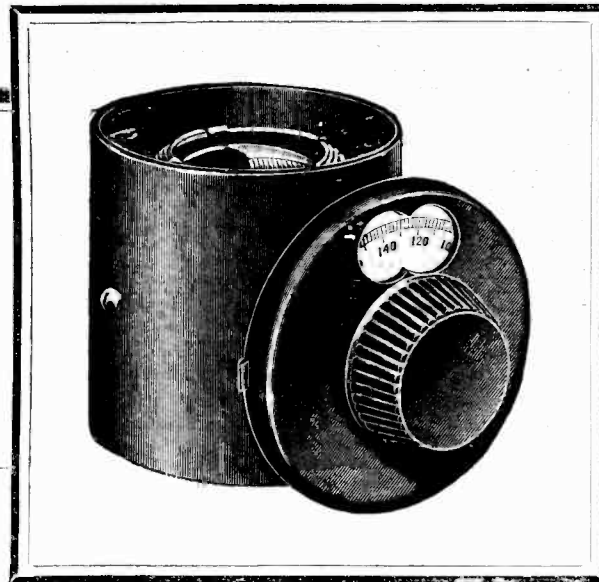

IGRANIC
VARIOMETER,
B. & B.L. TYPES.

IGRANIC-FRESHMAN
Fixed Condenser.



A new Variometer and a new Condenser

The "IGRANIC-FRESHMAN" Fixed Condenser is designed upon an entirely new principle, and so constructed as to render variations in capacity negligible. Will withstand high voltages and is eminently suitable for usual reception purposes and low-power transmitting. Dielectric losses almost non-existent.

PRICES :

.0001 mfd.	.0005 mfd.	} 2/- each.
.0002 mfd.	.001 mfd.	
.0003 mfd.	.002 mfd.	
.003 mfd.		} 2/6 each.
.005 mfd.		
.006 mfd.		

IGRANIC Variometer, B. & B.L. Types.
Wound on Air! Therein lies the great feature of this new type Igranich Variometer. The windings are self-supporting without the need for moulded insulation. Self-capacity is low and mutual inductance high. Windings are protected by a paxolin tube, and one-hole fixing is provided for. Type B. is for B.B.C. wavelength ranges, and type B.L. for Chelmsford, Radio-Paris, etc.

PRICES :

B.	280 to 650 metres	12/6
B.L.	700 to 2,400 metres	18/-

**IGRANIC
RADIO DEVICES include:**

Honeycomb Coils, Fixed Condensers, Filament Rheostats, Intervalve Transformers, Variometers, Vario-couplers, Bi-plug Coil Holders, Tri-plug Coil Holders, Battery Potentiometers, Vernier Friction Pencils, etc., etc.

In these latest Igranich achievements you will find that Igranich craftsmen have eliminated the failings of earlier variometer and condenser designs.

Both have proved their sterling merit in exhaustive and searching experimental work, and now we can confidently say (as we do of all Igranich Devices) that you will "build a better set" if these new Igranich Components form part of your receiver.

Write us for List Z359,

which illustrates and describes the complete range of Igranich Radio Devices. They carry a six months' guarantee and are stocked by all reputable dealers.



149, QUEEN VICTORIA STREET, LONDON.
 Works : Elstow Road, Bedford.

Branches : Birmingham, Cardiff, Glasgow, Leeds, Manchester, Newcastle.

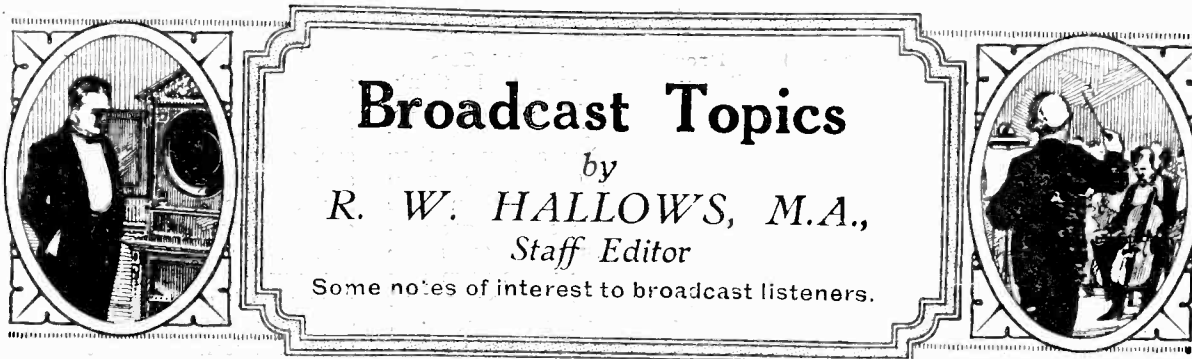

THOUGH he may speak scathingly of "broadcatchers," and so on, your genuine experimenter must admit in his heart of hearts that he himself spends far more time in listening to the programmes transmitted by broadcasting stations than in the reception of signals of any other kind. And, after all, why should he not? There are telephonic transmissions to supply nearly all his needs, and, other things being equal, it is much more entertaining to listen to speech and music than to decipher messages, usually of a most uninteresting type, sent out in Morse. It is only when he is working with amateurs in this country or in other parts of the world who use continuous wave telegraphy for their transmissions, or when he is picking up time signals from far corners of the earth, that telephony fails him. Another point is that ability to receive telephonic transmissions as they *should* be received is a far greater test of any set than the bringing in of Morse signals.

Morse Reception

With these latter a certain amount of distortion does not matter in the least—in fact, it will not be noticed; but for reproduction of telephony it is essential that distortion should be eliminated, for if it is present its effects will be devastating. In the early days of broadcasting the results that most of us obtained, though we were pleased with them then, were not very good. The reason was that we were working with apparatus designed mainly for reproducing a very limited range of notes. The note of a spark signal depends, of course, upon the transmitter in use, but a C.W. signal can be tuned by the man at the receiving set to the frequency which suits him best. This is usually somewhere between 750 and 1,000 cycles a second. Most low-frequency transformers and telephones were designed so as

to respond best to frequencies of this order, with the result that when they were called upon to deal with musical transmissions, which include frequencies varying between extremely wide limits they emphasised notes towards the middle of the scale whilst almost suppressing those at either end. We saw nothing in those days of special low-frequency valves with long straight grid-volts-anode-current curves, of transformers designed to have a flattened characteristic or of grid biasing batteries. The

than enough for everyone who heard the test.

A Proper Pride

To-day the real experimenter is distinguished from the mere listener largely by the pride he takes in the quality of his reception. He wants his set to be able to reproduce broadcast transmissions, and he aims at a standard that is as near to perfection as is humanly possible. He does not desire to have a set with a single control. Rather he prefers to have as many variable values as is reasonably possible

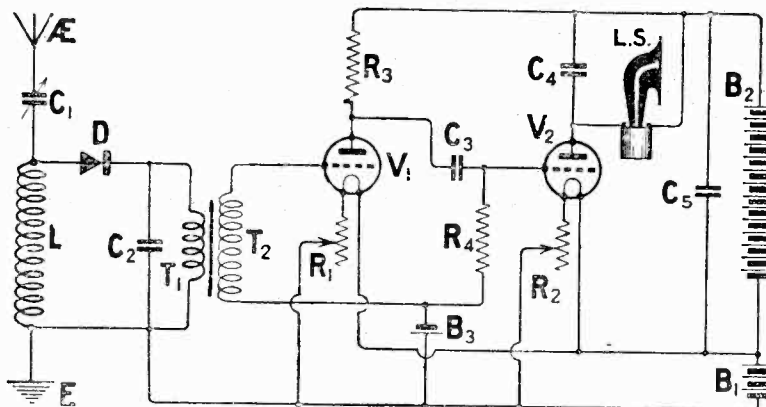

Fig. 1.—Crystal detector and 2 L.F. for distortionless reception.

loud-speaker was there simply to make a noise. The first one that I owned consisted simply of an ordinary telephone earpiece mounted on a stand and provided with a trumpet. It was excellent for bringing in spark or C.W. messages, but as an instrument for music it was beyond words. I did not realise how bad things used to be until the other day when I unearthed this ancient loud-speaker and the quaint set in conjunction with which it used to produce its bellowsings. A five minutes' trial with the combination, upon 2LO was more

in voltages, resistances, capacities, and couplings, for he knows that he can obtain the best results by the skilful adjustment of a large number of controls.

With regard to variable grid-leaks, experience has shown that many are not very satisfactory, since in the first place they cannot easily be calibrated, and in the second some are apt to "pack," so that what was originally the minimum resistance becomes in time the maximum. In place of them I am going to substitute clips on the upper surface of the panel, into which fixed gridleaks of

ULTRA

REGISTERED TRADE MARK

ADJUSTABLE PHONES

are still the BEST

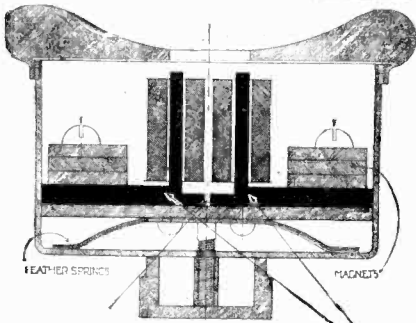

FIRSTLY.—Because the Pole Shoes are laminated, thus minimising eddy currents.

SECONDLY.—A Magnetic Shunt-Pass is provided, which eliminates distortion.

THIRDLY.—The Vernier Adjustment is perfect in its action.



4,000 Ohms

THESE ADVANTAGES ARE EXCLUSIVE TO "ULTRA."

20/- per pair

ASK YOUR DEALER FOR THEM

Should you have any difficulty in obtaining same, write direct to

Messrs.

EDWARD E. ROSEN & CO.
158-160, City Road, London, E.C.

with the name of your Dealer.

various values can be clipped in a moment.

Broadcast Receiving Sets

Every experimenter, I think, should have one set designed specially for the reception of broadcasting—if he has a family they will see to that! Captain Eckersley has stated on more than one occasion that you cannot get perfect reception at a greater range than about thirty miles from any station. His point is that as soon as you exceed that distance you must either make large use of reaction or employ high-frequency amplification, both of which are liable to have the effect of bringing in mush and excessive atmospheric disturbance.

Though one can obtain quite good reception at much greater ranges, I think that the special broadcasting set should be designed

resistance capacity coupling whose excellence for telephonic reception is becoming more and more generally recognised. Provided that the transformer is a good one, excellent reproduction will be obtained with such a circuit, and it has the added advantage that it is simple enough for anyone to use. At rather greater distances the circuit shown in Fig. 2 will be found admirable for pure reception. Should the volume of sound not be great enough, a second note magnifying stage, resistance capacity coupled, as in Fig. 1, may be added. The high-frequency transformer may be tuned or semi-aperiodic. Where the distance is not excessive the semi-aperiodic transformer will be found satisfactory. Though not so efficient as the tuned, it has not the same tendency to produce oscillation, and since the set is

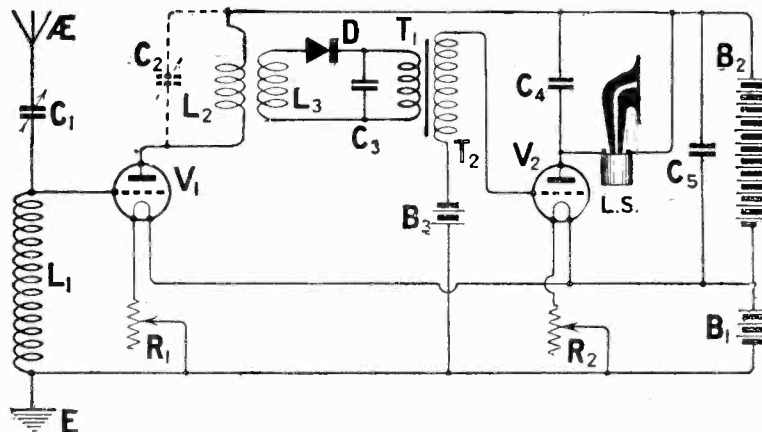

Fig. 2.—Excellent quality and greater range are obtained with the above circuit than with Fig. 1. The Condenser C₁ can be used in series or in parallel.

mainly for dealing with the transmissions of the nearest main station. The experimental set can be used for the fascinating pastime of trying round for distant signals.

The Circuit to Use

If you are going to work on these lines, what is the best circuit to use for the set devoted entirely to broadcasting? This will depend mainly upon the proximity of the house in which it is used to the nearest main station as well as upon local conditions. Some places are much above the average from a wireless point of view, whilst others may be classed as blind or semi-blind spots. For the normal locality I do not think that you can beat the circuit shown in Fig. 1 up to about ten miles. Here a crystal rectifier is used, coupled by means of a low frequency intervalve transformer to the first valve. Between the first and second valves we have

always worked well away from the point of oscillation, little mush comes in. Should there be local interference from spark stations a double circuit tuner will be found to be an advantage as an addition to either the Fig. 1 or Fig. 2 circuit. If the last valve in either case is to be a power amplifier, a second high-tension tapping will be necessary, and there should be a higher grid voltage than is applied to the first valve.

Transmission Quality

It should be noted that the receiving set is not always entirely to blame for slight imperfections in speech or music. Though the general standard of the broadcasting stations is excellent, the quality does vary a little from time to time, owing, one imagines, to experimental alterations in the circuits used. When 5XX first began to transmit he could not

approach the mellowness of 2LO. It was natural that considerable difficulties would be encountered when an attempt was made to modulate the huge output of the big station. Of late he has improved very greatly, and his quality is now very little inferior to that of the lower powered station. Even 2LO, whose transmissions are normally of excellent quality, varies a little. During the latter part of October, for example, a distinct roughness was noticeable on several evenings. If, therefore, you are trying out a new set, do not condemn it until you have satisfied yourself by testing it on several evenings on a transmission which is known normally to give good reproduction.

Interference

The interference due to radiation from oscillating receiving sets is, I think, distinctly less than it was some months ago. I can remember many evenings about this time last year when it was impossible to listen to the transmission of one's nearest main station with any kind of pleasure owing to the squeals, yells, howls and chirps with which the entire programme was punctuated. Many a time, in despair, I have gone over to Radio-Paris, only to find as often as not that some of the squealing band were doing the same thing. The improvement is due, I think, largely to the fact that users now understand a good deal more about their sets than they did, and that they have become much more skilled in controlling them. Then, thanks largely to the able constructional articles in MODERN WIRELESS, the home-made set of to-day is a very much more efficient and a far more stable instrument than it was in the earlier days of broadcasting. I am not going to be so bold as to say that interference has ceased to exist. It has not, for there are still some who nightly disturb the ether in their efforts to obtain just a little more volume of sound. Still, they are on the decrease, and as wireless education progresses we may expect to find that interference continues to grow less. The worst type of man now, as in the old days, is he who is never satisfied with his tuning.

Wonderful Modulation

Besides British broadcasting stations, all experimenters are now familiar with large numbers of those situated on the Continent. Some of these are remarkable for the constancy and the quality of

their transmissions. The best of all, I think, is the Spanish station Radio Iberica, which, in spite of the great distance separating Madrid from this country, comes in with extraordinary strength and purity. From London to the Spanish capital is about 800 miles in a straight line. I do not think that any other transmission from anything like this distance can touch that of Radio-Iberica for excellence. The modulation is so perfect that every syllable spoken can be heard with the utmost distinctness, whilst music comes through with a beautiful tone and without distortion. Another good Continental station is L'Ecole Superieure des Postes et Télégraphes, which transmits from Paris, and some of the German stations come through very well indeed.

Fading

It is curious to notice how some of the British stations are affected by fading, whilst others, even though they are at greater distances, do not appear to suffer in this way. As received in Hertfordshire, for example, Bournemouth's signals are more given to this effect than those of any other station. On a selective set he can be separated without much difficulty from 2LO, but when you have got him you find that his strength varies, especially early in the evening. Cardiff, in the same locality, suffers to some extent from fading, but he is not nearly so bad as Bournemouth. Another rather strange phenomenon is that the stations appear to have periods of good and bad strength. Cardiff, for example, was a strong transmission here during the spring, but by midsummer he had become so weak that it was next to impossible to get him at all. At the end of August he was fairly good. Manchester, again, is a station that I can never rely upon. Sometimes for weeks on end I can get him without much difficulty; then comes a time when one finds that it is most difficult to hear him at all. Here the most consistently good British stations seem to be Newcastle, Birmingham and Aberdeen—I am not, of course, taking 2LO into account, for he is so close that, except when he varies his power a little, his transmissions are always good.

Quality RADIO COMPONENTS.



Prov. Protected.

CAM-VERNIER COIL HOLDER

With Reaction Reverse and Shorting Switch.
Price 12/6. Without Switch, 9/-
Postage 4d.
Panel Mounting Swivelling coil Socket for T.A.T. circuit. Price 1/6 each, postage 2d.



CONDENSER & SET CLEANER

Price 6d. each. Postage 2d.



FOR PANEL WIRING FOR SURFACE WIRING



LEGLASS VALVE HOLDER

This new pattern valve holder is a great time saver for the home constructor, no marking out for the legs being necessary. With Insulated Plate Socket. Prov. Prot.
Price 1/6 Postage 2d.
Fitted on square ebonite base for table use, 6d. extra.
If your dealer has not got them we send post free if you mention his name and address.

LIST POST FREE:

GOSWELL ENGINEERING CO., LTD.,

12a, PENTONVILLE RD., LONDON, N.1.
Liberal Trade Terms. Phone: North 3051.

OUT JANUARY 15th.
"The Wireless Constructor."
ORDER EARLY.

The "Simplicity" Envelope Set in Egypt

The Simplicity Set.

SIR,—Having noticed in MODERN WIRELESS that you ask for results with sets, I have pleasure in giving some obtained with your "Simplicity" set.

This circuit was chosen from the advertisement in MODERN WIRELESS solely on the "one-knob" control idea, and I find it is "simplicity" itself—practically simply turning the condenser.

I was rather sceptical of getting any long-distance results, and was greatly surprised on testing it here (on a steamship) to hear several home stations.

Manchester comes in loudest, at good strength, as does 2LO, and three others at readable strength.

All these on two valves only! With the third valve on, the atmospherics are deafening, but Manchester can be heard with 'phones on the table.

A station, I believe German, and one other come in very loud on

about 600 metres, the transmitting valves humming very loudly.

I have also heard these stations at about the same strength with no earth wire connected, although the tuning was altered.

Chelmsford and Radiola come in fairly well on all valves, but I have not bothered much with these.

In this place intelligible concerts are impossible on account of atmospherics, which are continuous and loud, and to hear these stations through them is a very good performance.

No difficulty was found in building the set.

The only modifications are a variable resistance, used instead of 70,000 ohms, and 3 in. tube instead of 2½ in. for winding the coil with extra length of wire allowed for in tapping. These were unobtainable in the short time available before leaving England, so had to do the best I could. The No. 40 gauge wire was actually sent out here by post.

In conclusion, I wish to congratulate you on turning out such a fine magazine as MODERN WIRELESS, to which I subscribe.—

Yours truly, "BERMIN."

Alexandria, Egypt.

P.S.—Distance London to Alexandria is roughly 2,000 miles.

H.F. TRANSFORMER CONNECTIONS IN "TRANSATLANTIC" RECEIVERS.

IN the construction of the "Transatlantic" receivers the connections to the H.F. transformers given are those which have produced the best results. The effect of reversing either of the windings should be tried with makes of plug-in transformers other than those used in the original design. Actually, no notice has been taken of the makers' marks on these transformers, the correct scheme of connections having been arrived at by actual trial. Although McMichael transformers were originally used, these are immediately interchangeable with Bowyer-Lowe, Peto-Scott, Magnum and some others. With certain other makes it may be necessary to experiment with different connections in order to get the best results.

"An Entire Success"



Per 20/- Pair.

General Radiophones respond faithfully to the minutest signal intensity. The new method of matching the ear-pieces by automatic gauges and the incorporation of carefully designed sound chambers ensure wonderfully clear and natural reception. Ask your dealer for a demonstration.

writes W. L. S —, B.Sc. Here's his letter—it's typical of the many we receive from satisfied users of "General Radiophones."

Kings College, W.C.2.

Dear Sirs,

Kindly allow me to express my appreciation of your achievement in your "General Radiophones." I have frequently applied them in many exacting scientific experiments in the place of delicate galvanometers and find them an entire success.

Their extreme sensitivity, their lightness and durability combined with extreme beauty of external appearance make them an exceptionally good investment especially in view of their moderate price.

Personally, I prefer them to many makes of 'phones nearly double the price and recommend them unreservedly.

I am, Sirs,

Yours sincerely,

W.L.S.— B.Sc.
(1st. Hous.)

GENERAL RADIO COMPANY LIMITED.

Radio House, 235, Regent St., London, W.1.

Telephone: Mayfair 7152.

Telegrams: Algenrad London.

Branches in all principal towns in Great Britain and in principal countries overseas.

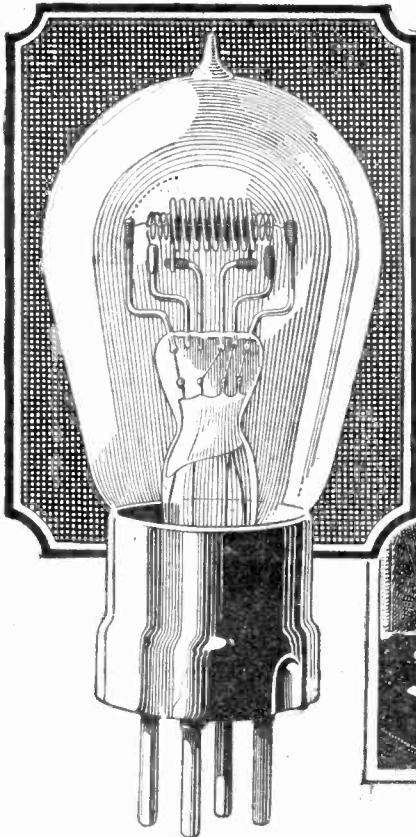

Louden

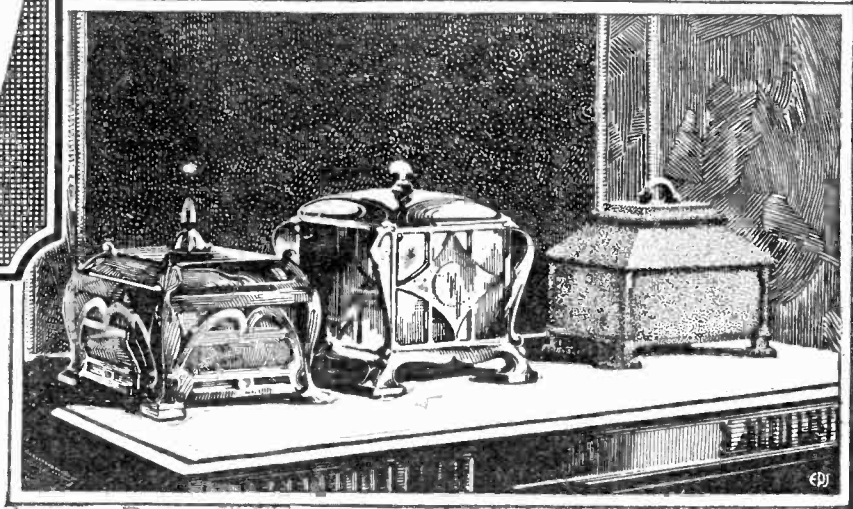

The three caskets

10/-

It was not the Golden Casket that contained Portia's portrait, but the lead; and so it often happens that the most expensive article is not necessarily the one most to be desired.

There are many valves more expensive than the Loudens; yet there is not one of them that combines all its many advantages.

It uses considerably less current from the accumulators than is usual amongst valves of the bright filament type—a point which

needs no labouring to those anxious to keep down costs.

It gives a reproduction full in volume and silver clear in quality, and it has a stout filament which is not readily broken.

Further, it only costs 10/-.

Four months ago people had not heard of Loudens; to-day they are demanding them at the rate of many thousands per week—which is, perhaps, the most striking testimony of all.

See that your next valve is a Louden.

**Louden
VALVES**

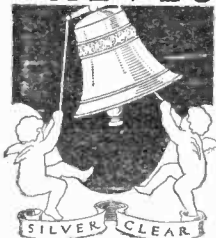

*The Plain Loudens for
Detecting and Low Fre-
quency Amplifying.*
The Blue Loudens for H.F.
Amplification.
Filament Volts .. 4.8-5
Filament Amps... 0.4
Anode Volts .. 40-80

**FELLOWS
WIRELESS**

*Manufactured throughout
in Great Britain.*

All Loudens are silver
clear and free from mush.

The current consumption
is low and the life long.

Louden Valves - Silver Clear

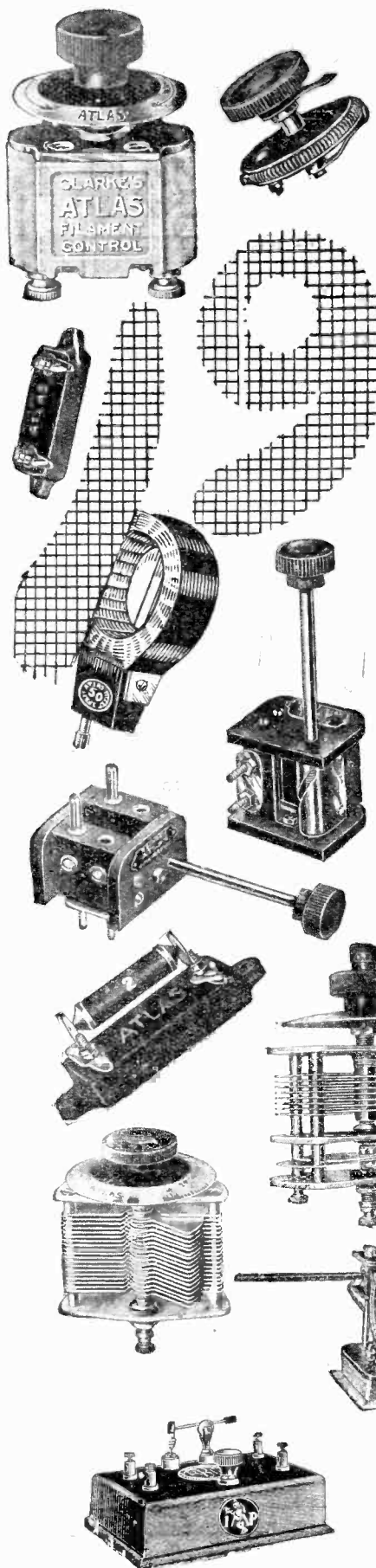

25

*- make it
"the best yet!"*

It depends largely upon yourself. One very simple rule will make all the difference between radio success and possible failure. Don't expect to build an A.1 set from C.3 components. Ask your dealer to show you Clarke's "ATLAS" radio specialities. There isn't an "ordinary" component in the whole of the range. Many of the devices are patented, and in more than one instance the components are complimented by "the sincerest form of flattery."
Even if you don't as a rule believe in New Year resolutions, you will be glad you made this one "I'll always ask for

**"CLARKE'S
ATLAS
SPECIALITIES**

Sole Manufacturers :-
H. CLARKE & CO. (MANCHESTER) Ltd.

RADIO ENGINEERS, ATLAS WORKS,
OLD TRAFFORD, MANCHESTER

Phones, 683 & 793 Trafford Park.
Grams, "Pirtoid, Manchester."

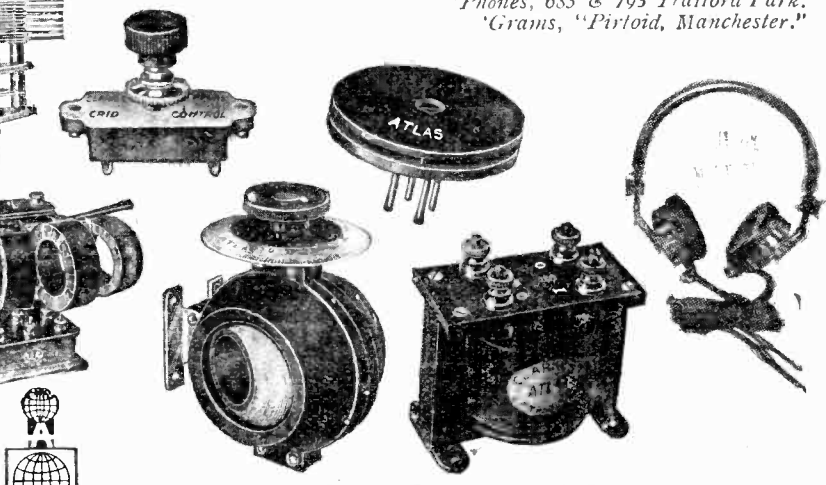

SOME THREE-VALVE REFLEX CIRCUITS.

Arranged by JOHN SCOTT-TAGGART, F.Inst.P., A.M.I.E.E.

This interesting article should provide ground for much useful experimenting in reflex working.

A good Three-Valve Dual Circuit

FIG. 1 shows a three-valve reflex circuit in which the first valve acts in dual capacity as a high- and low-frequency amplifier, the second valve as a detector, and the third simply as a low-frequency amplifier. The circuit L_1C_1 is tuned to the incoming oscillations, and the varying potentials are applied to the grid of the valve V_1 . In the anode circuit of V_1 is connected the primary L_2 of a high-frequency transformer as shown, the secondary L_3 of which is tuned by the condenser C_2 . The amplified oscillations in the anode circuit of the first valve thus cause varying potentials across the grid-filament circuit of the second valve, which acts as a detector, the usual grid condenser C_3 and gridleak R_4 being provided.

Low-frequency Amplification

In the anode circuit of the detector valve is connected the primary T_1 of a low-frequency transformer T_1T_2 , the secondary T_2 of which is connected in the grid circuit of V_1 as shown. The rectified currents in the anode circuit of V_2 thus cause varying potentials to be applied to the grid of the valve V_1 , and amplified currents appear in the anode circuit of V_1 , in which is connected the primary T_3 of a second step-up interval transformer T_3T_4 . The secondary T_4 is connected across grid and filament of the valve V_3 , which gives the last stage of note-magnification, the loud-speaker being connected in the anode circuit of this valve.

Provision is made for adding grid bias to the amplifying valves by including a grid battery GB as shown in the circuit diagram. Reaction is provided by including a coil L_4 in the anode circuit of the valve V_2 and coupling this coil to L_1 .

Suitable coil values for the broadcast wavelengths are Nos. 35 or 50 for L_1 , a No. 50 or 35 for L_4 , while the H.F. transformer L_2L_3

should be of suitable design for the wavelength range to be covered. The variable condenser C_1 may be a $.0005 \mu F$, and for C_2 a convenient value is $.0003 \mu F$. Note that no condenser is shunted across the primary T_1 of the L.F. transformer T_1T_2 . One may be tried here, but usually the self-capacity of the primary windings is sufficient. C_6 has a value of $.001 \mu F$, but experiments should be tried to see whether smaller values, e.g., $.0003 \mu F$, work better. The anode voltage of the detector valve should be smaller than the other anode voltages. A C.A.T. condenser of $.0001 \mu F$ may be tried in series with the aerial.

tension battery B_2 do not form part of the actual aerial circuit. The circuit L_1C_2 is tuned to the incoming oscillations, and the coil L_1 , when first tuning in, should be kept well away from the coils L_2 and L_3 , which will usually be fairly close. The high-frequency potentials are communicated to the grid of the first valve V_1 through the condenser C_6 , a gridleak R_3 being provided to prevent an accumulation of electrons on the grid. The condenser C_6 serves to prevent the high positive potential of the high-tension battery being communicated to the grid of V_1 . Amplified high-frequency oscillations appear in the coil L_2 to which

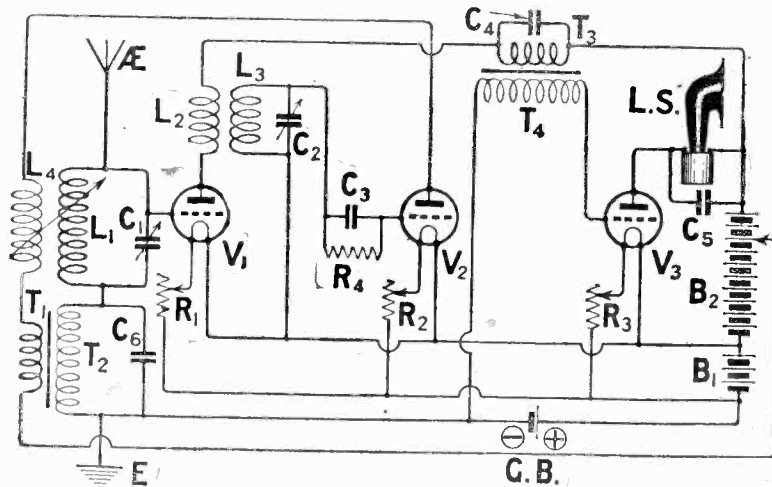

Fig. 1.—A highly efficient Three-Valve Dual Circuit.

A Three-Valve "Resistoflex" Circuit

The Fig. 2 circuit embodies the resistoflex principle, and the now well-known tri-coil coupling. It will be seen that the first valve V_1 acts as a high-frequency amplifier, the aerial circuit containing the constant aerial tuning condenser C_1 , the main oscillation circuit L_1C_2 , a condenser C_3 , another condenser C_4 , and the earth. The resistance R_1 , of 100,000 ohms, which is really in the anode circuit of the second valve and the grid circuit of the first, and the high-

is coupled the coil L_3 , tuned by the condenser C_7 . High-frequency potential variations are thus set up across the grid and filament of the valve V_2 which acts as a detector, the usual grid condenser C_8 and gridleak R_6 being provided. The low-frequency impulses in the anode circuit of V_2 pass through the high-resistance R_1 , through the battery B_2 , and thence to the filament of the second valve. In passing through R_1 , low-frequency potential variations are produced across this resistance, and these are applied to the grid of the first

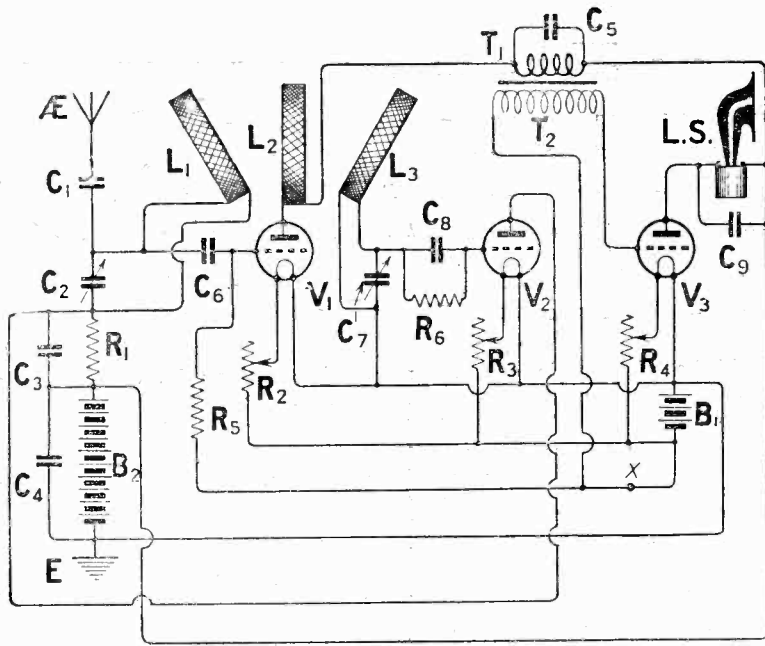

Fig. 2. A Tri-Coil Resistoflex Arrangement.

valve V_1 through the coil L_1 and the condenser C_6 . The first valve thus gives both high- and low-frequency amplification. The amplified low-frequency impulses in the anode circuit pass through the primary T_1 of a low-frequency transformer T_1T_2 , the secondary T_2 of which is connected across the grid of the third valve and L.T. —. This third valve therefore acts simply as a note-magnifier, and the low-frequency impulses pass through and operate the loud-speaker L.S., connected in the anode circuit of V_3 and shunted by a fixed condenser C_9 . A grid battery may be connected at the point X to give negative bias to the grids of the first and third valves.

Reaction Control

A control of reaction is obtained by varying the positions of L_1 and L_3 with respect to the centre fixed coil L_2 . L_2 and L_3 should usually be as close together as possible. For the broadcast wavelengths above, say, 350 metres, suitable coil values are Nos. 35 or 50 for L_1 , if C_2 is of $.0005 \mu F$, a No. 50 or 75 for the middle coil L_2 , and a No. 75 for L_3 , this being tuned by C_7 of $.0003 \mu F$. Other values are $.0003 \mu F$ for C_3 , 1 or $2 \mu F$ for C_4 , 100,000 ohms for R_1 , the gridleaks R_5 and R_6 being 2 megohms. C_6 has a value of $.0003 \mu F$, although some experimenters have found a higher value better. If the circuit tends to oscillate unduly, reverse the leads to L_1 .

The S.T. 119 Circuit

The three-valve circuit of Fig. 3 involves dual amplification in the

first valve and rectification by crystal detector after two stages of high-frequency amplification, the last valve acting simply as a low-frequency amplifier. The coupling between the first two valves consists of a tuned anode circuit L_2C_2 tuned to the incoming wavelength. In the anode circuit of the second valve we have the circuit L_3C_3 also tuned to the incoming wavelength. The crystal

first valve which amplifies them, the amplified low-frequency currents passing through the primary T_3 of the step-up intervalve transformer T_3T_4 , the secondary of which is connected across the grid and filament of the third valve as shown. The loud-speaker is connected in the anode circuit of the third valve V_3 , the condenser C_7 being optional. Experiment should be made to determine the best values of the fixed condensers C_4 and C_5 . For the reception of broadcasting, L_1 may be a No. 35 or 50 coil, L_2 and L_3 both No. 75. Suitable condenser values are $.0005 \mu F$ for C_1 and $.0003 \mu F$ for C_2 and C_3 .

A 2-H.F. Reflex Circuit

Fig. 4 shows a three-valve reflex set in which there are two stages of H.F. amplification, a valve detector and one stage of low-frequency amplification. The low-frequency currents being fed into the grid circuit of the first H.F. amplifier. The circuit works as follows: The circuit L_1C_1 is tuned to the incoming frequency, and varying H.F. potentials are set up across the grid and filament of the first valve. Amplified oscillations appear in the anode circuit L_2 , which is the primary of an H.F. transformer, the secondary of which, L_3 , is connected across the grid of the second valve, and the slider of a potentiometer R_3 connected across the L.T. battery; potential

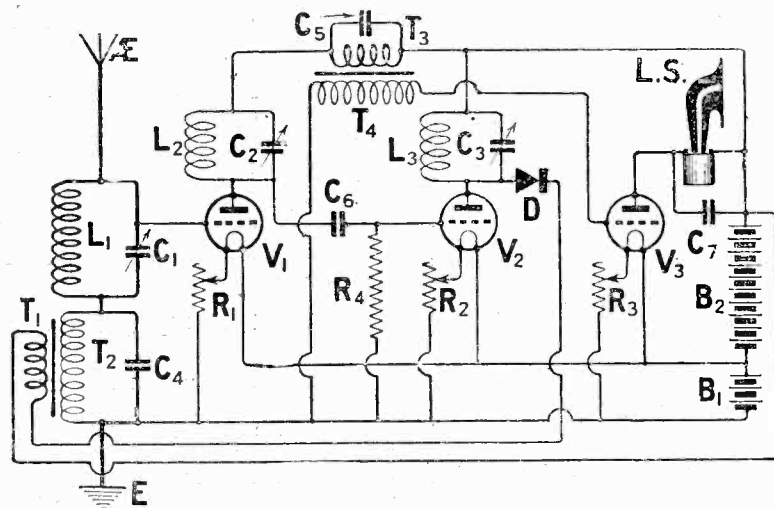

Fig. 3.—The S.T. 119 Circuit.

detector D and the primary T_1 of the intervalve transformer T_1T_2 are connected in series across the anode circuit of the valve V_2 . The amplified high-frequency oscillations in the anode circuit of V_2 are rectified by the crystal, and low-frequency currents are introduced into the grid circuit of the

variations are therefore applied to the grid of the second valve V_2 , the anode circuit of which contains the primary L_4 of a second H.F. transformer L_4L_5 . The secondary of this is connected across the grid of the detector valve V_3 , and L.T. + having the usual grid condenser C_5 and gridleak R_4 .

HULLO, EVERYBODY!!

RAYMOND'S VARIABLE CONDENSERS

All our condensers have been tested and recommended by leading journals. (Unsolicited)

"DE LUXE" MODEL



As shown with dial, knob and bush.

'001	7/3
'0005	5/11
'0003	5/4
'0002	4/11

Post 6d. Set.

UNSURPASSED FOR FINE TUNING. NEW MODEL

With vernier.

'001	- 9/3
'0005	- 7/3
'0003	- 6/9

With EBONITE DIAL and Two Knobs. Post 6d. Set.



SQUARE LAW TWIN VARIABLE CONDENSER

Ebonite ends. knob & dial.

Equal parts of	
.00025 or .0003	12/6
ditto .0005	18/11



NEW MODEL SQUARE LAW WITH VERNIER

POST FREE	AL'MN ENDS	EBONITE ENDS
'0003	10/-	11/6
'0005	10/11	12/6

LONDON'S LARGEST STOCKIST OF JACKSON BROS. VARIABLE CONDENSERS.

Square-Law.		Standard.	
.001	9/6	.001	8/6
.0005	8/-	.0005	7/-
.0003	6/9	.0003	5/9
.0002	5/6	.0002	5/-

N. & K. No. 3, Latest Model .. 17/6
New 3-Pole Laminated Magnets, which ensure an even magnetic pull and still greater volume.

IMPOSSIBLE TO EQUAL FOR CRYSTAL SETS.

LISSEN.

Variable Grid Leak	2/6
Anode Resistance	2/6
Lissen Minor	3/6
Lissenstat	7/6
Do. Universal	10/6
2-way Switch	2/9
Series Parallel	3/9
T1 Transformers	30/-
T2, 25/- T3, 16/6	
Coils: 25, 4, 10, 30, 35, 40, 4/10, 50, 5/-, 60, 5/4, 75, 5/4, 100, 6/9, 5-point Switch	4/-
Lissen Choke	10/-
Aux. Res.	1/3

L.F. TRANSFORMERS

Radio Instruments	25/-
Igranite, Shrouded	21/-
Powquip, Shrouded	18/-
Formo, Shrouded	18/-
General Radio	14/11
Formo, Open	12/6
Formo, 14	14/6
Powquip, 4-1	10/-
Raymond	10/-
Eureka Concert	30/-
Grand	22/6
Ditto, 2nd Stage	17/6
Feranti	21/-
Success Super	21/-

VALVES.

Thorpe K4 (5-pin)	17/6
Phillips 4 Electrice	12/6
(Both for Unidyne)	

BRIGHT EMITTER.

12.6 each.	
B.T.H.	R. Type
Ediswan	A.R.
Marconi-Osram	
R. or R 5 V	
Mullard-Ora	
Cossor	P.1.
Cossor	P.2.
Myers-Universal	
Mullard H.F. (Red Ring)	
Mullard L.F. (Green Ring)	

DULL EMITTER AND

Marconi, Ediswan, Mullard, Cossor, at Usual Prices.	
---	--

HEADPHONES.

B.T.H., 4,000 ohms	25/-
G.R.C., 4,000 ohms	20/-
Brandes, 4,000 ohms (Matched Tone)	25/-
Brown's, 4,000 ohms	25/-
Sterling, 4,000 ohms	25/-

Genuine DR. NESPER HEADPHONES

Adjustable diaphragm, detachable receivers, double leather-covered, headsprings, long flexible cords, nickel-plated parts. Very comfortable fitting to the head. LOOK FOR THE TRADE MARK. 4,000 ohms. .. 12/11
Post 6d. pair.

CALLERS! THESE 3 COLUMNS FOR YOU NO POST ORDERS FOR SAME.

Lead-in tubes: 6d., 7d., 8d.	2-meg. Leaks .. 10d.	Terminals complete
Valve Pins and Nuts 2 a 1d.	Cheap Fixed .. 6d.	Brass Pillar .. 1d. 11d.
Stop Pins and Nuts 2 a 1d.	RAYMOND FIXED CONDENSERS.	
Nickel Terminals .. 2d.	.001, .0001 to .0005 10d.	W.O. or 'Phone 1d. 11d.
Nickel Contact Studs .. 2 for 11d.	.002, .003, .004 .. 1/-	Fancy Patterns .. 1d. 11d.
Nickel Switch Arm (one-hole fixing) 1/-	.006, 1/3, .01, 1/9, .02, 1/9.	Extra large .. 2d. 3d.
Loading Coil and Plug .. 8d.	D.C.C. Wire, per lb. 13 g. .. 9d. 20 g. .. 9d.	Valve Sockets, 2 for 11d.
Gamages Permanite 1/-	22 g. .. 10d. 24 g. .. 1/-	Machine cut Screws.
Condenser Brushes 6d.	26 g. .. 1/1 28 g. .. 1/3 30 g. .. 1/6 Etc., etc.	Stckcd (Best).
		Pulleys .. 41d.
		4 Taps and Wrench 2/11
		Screwdrivers .. 6d.

LARGE NUMBER OF BARGAINS TO CALLERS ONLY

ACCUMULATORS.		H.T. BATTERIES.	
No Post Order at present.	Neutron Crystal .. 1/6	60 v. .. 7/6	
2 v. 40 amps .. 9/6	Uralium .. 1/-	30 v. .. 4/6	
4 v. 40 amps .. 16/6	Midite .. 6d.	60 B.B.C. .. 9/6	
4 v. 60 amps .. 18/6	Enclosed Detectors 9d.	36 B.B.C. .. 5/6	
4 v. 80 amps .. 23/6	Large, Brass, on base 1/3	9 v. B.B.C. .. 2/6	
6 v. 60 amps .. 27/6	Ditto, Nickel, on base 1/6	1.5 (C.E.) .. 1/9	
6 v. 80 amps .. 33/-	MicMet Type .. 2/8	Ditto .. 2/- to 3/-	
6 v. 105 amps .. 38/6	Variometers (special) 1/6		
Hart's Stocked. All High Quality.	Ditto, with clips, etc. 2/3		
	Ebonite D.C.C. and Dial .. 3/9		
	Also at 3/11, 4/3, 4/6 up.		

"DE LUXE" SUPER LOUD SPEAKER. 2,000 ohms, 24" TYPE VALVE 15/11

"REAL" BARGAIN.		BUS-BAR.	
Legless Valve Holder 1/-	1/16 sq. 15 feet 6d.	18 sq. 15 feet 5d.	
Solid Rod Ditto .. 1/-	Microstat .. 2/6	Switch Arms 8d. to 1/-	
Under Panel Ditto .. 1/6	Flex (Red and Black) per yd. .. 3d.	Shellac .. 5d.	
Ebonite Dials 8d., 1/-	Loading Coil and Plug .. 8d.	Contact Studs 4 for 11d.	
Valve Templates 2d. (d.)	Nickel ditto 2 for 11d.	Nickel Switch Arm 1/-	
Electron Aerial 2d. 1/3	Sorbo Earcaps, pair 1/4	Tumbler Switches .. 1/4	
Adhesive Tape Roll 21d.			
Copper Foil, per foot 2d.			
1 in. Fibre Strip, 3 ft. 2d.			
Insulated Hooks 4 for 3d.			
Ditto Staples 5 a 1d.			

"ORMOND" L.F. 13/11 A Wonderful Transformer. 16g. D.C.C. USUALLY IN STOCK.

Twin Flex, 4 yds. 6d.	
Twin Silk Small, 6 yds. 6d.	
D.C.C. Bell Wire 10 yds. 5d.	
Knobs, 2 B.A., 2d., 3d., 4d.	
Small Knobs, 6 B.A. 3d.	
Small Knobs, 4 B.A. 3d.	
Wander Plugs, pair 3d.	
Egg Insulators, each 1d.	
Tape Aerial, 100 ft. 2/-	
Valve Windows, 4d. to 9d.	
Mica .. 2d.	
.06 VALVES .. 12/6	

COSWELL COIL STANDS.

2-Way Cam Vernier 9/-	
3-Way Cam Vernier 12/6	
3-Way Ordinary .. 7/6	
2-Way Panel .. 3/-	
3-Way Panel .. 5/-	

RAYMOND CRYSTAL SETS, 7/11, 9/11, 12/11.

2 B.A. rod, per ft. 21d.	
4 B.A. Rod, per ft. 2d.	
Basket Holders .. 81d.	
Also at 10d., 1/-, 1/3, 1/6	
2-way Coil Stands .. 1/11	
3-way Ditto .. 4/3	
2-way with ex handles 2/11	
3-way ditto .. 4/9	
4-5 Batteries, 41d., 5d.	
Brass Coil Former .. 2/11	
Twist Drills .. 1/4	

NOTE! Our Wonderful Micro-meter Adjustment Glass-enclosed Detector. Why pay more? 1/9

BUY RAYMOND GOODS.	
5 Waxless Coils 200 2000 .. 1/5	
5 equal 25 to 100 .. 1/11	
5 ditto, Extra Air Space .. 2/8	
6 waxed 200/3600 .. 1/8	
7 waxed 150 3600 .. 1/11	
Chelmsford D.C.C. 1/-, 1/3, 2/6	
With adapter, 9d. extra.	
Switch Arm, 12 Studs, 12 Nuts, 12 Washers. Lot 101d.	

DUBILIER.

.001, .002, .003, .004, .005, .006, Fixed .. 3/-	
.0001, .0002, .0003, .0004, .0005 .. 2/6	
Type 577, .01 .. 7/6	
Grid Leaks, each .. 2/6	
Anode Resistance 50,000, 70,000, 80,000, 100,000, on stand complete .. 5/6	

ICRANIC.

Coils: 25, 5/- 35, 5/-	
50, 5/2 75, 5/6 100, 7/-	
150, 7/10 200, 8/8	
250, 9/- 300, 9/5	
400, 10/3 500, 10/8	
File Rheostat .. 4/6	
Potentiometer .. 7/-	
30-ohm Rheostat .. 7/-	

EDISON BELL.

.0001 to .0005 Fixed .. 1/3	
.002 to .006 .. 2/-	
.001 .. 1/3	
.0003 with Grid Leak .. 2/6	
Variometer .. 10/6	
Twin Detector .. 5/6	

RHEOSTATS.

Shipton's, 30 ohms .. 3/6	
Pot'meter, 600 ohms 4/6	
T.C.B., 6, 15, 30 ohms. 4/-	
Pot'meter, 300 ohms. 5/-	
Raymond 1-hole fixing .. 1/6	
G. & S. .. 1/6	
Special with Dial .. 2/6	

POLAR VARIABLE.

.001, .0005, .0003, ea. 10/6	
2-Way Cam Vernier 6/-	
2-Way Do. Universal 11/-	

VALVE HOLDERS.

Murray (Low Cap.) .. 1/3	
Bretwood (U.P.) .. 1/9	
Solid Rod Ebonite .. 1/3	
Various .. 1/-, 1/3, 1/6	
5-Pin for Unidyne .. 1/6	

BRETWOOD.

Var. Grid Leak .. 3/-	
Anode Resistance .. 3/-	

FOR FULL POST LIST SEE "POPULAR WIRELESS" AND "WIRELESS CONSTRUCTOR."

RIGHT OPPOSITE DALY'S GALLERY DOOR

K. RAYMOND

27, LISLE STREET, LEICESTER SQUARE, W.C.2

No responsibility accepted on post orders unless cheques and postal orders are crossed and made payable to the firm. Moneys sent must be registered.

HOURS OF BUSINESS: DAILY - 9 to 7.45 SUNDAY, 10 to 1

PHONE: GERRARD 4637.

Fit Radion Valves and Amplify Enjoyment

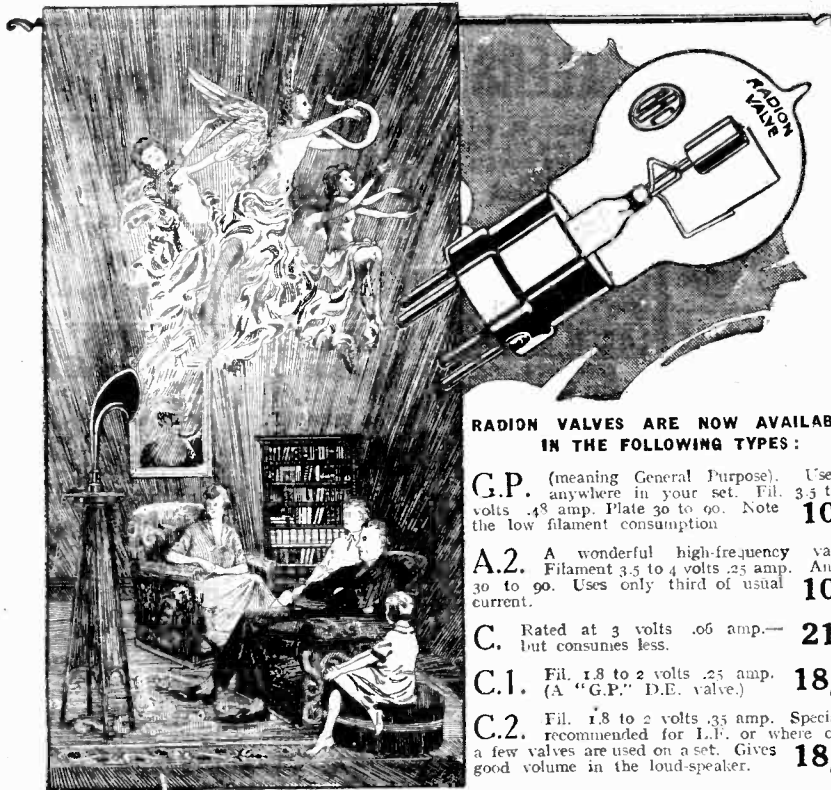

RADION VALVES ARE NOW AVAILABLE IN THE FOLLOWING TYPES:

- G.P.** (meaning General Purpose). Use it anywhere in your set. Fil. 3.5 to 4 volts .48 amp. Plate 30 to 60. Note the low filament consumption. **10/-**
- A.2.** A wonderful high-frequency valve. Filament 3.5 to 4 volts .25 amp. Anode 30 to 90. Uses only third of usual current. **10/-**
- C.** Rated at 3 volts .06 amp.—but consumes less. **21/-**
- C.1.** Fil. 1.8 to 2 volts .25 amp. (A "G.P." D.E. valve.) **18/6**
- C.2.** Fil. 1.8 to 2 volts .35 amp. Specially recommended for L.F. or where only a few valves are used on a set. Gives good volume in the loud-speaker. **18/6**

Immaculate Music

YOUR radio music will indeed be flawless if you fit Radion Valves, for not only do they use less current, but they can bear comparison—type for type—with any other product that the market boasts. Note, too, Radion Valves cost you less. If you write for the pamphlet offered below, we'll send some "curves" along, too.

FREE Write at once for a copy of our useful and interesting folder showing the service your accumulator should give.

It's free and post free. Write to-day

We are the pioneers of valve repairs—separate literature free on request.

RADIONS, LIMITED
Bollington, Macclesfield

Distributing Agents for Northern Ireland:
J. C. HOLLAND & CO.,
27, Franklin Street, BELFAST.

Distributing Agents for Scotland:
W. BROWN & CO.,
208, St. Vincent Street, GLASGOW.

RADION VALVES

NO AERIAL, EARTH OR ACCUMULATORS REQUIRED.



The "Rolls" Portable

THE SIMPLEST, NEATEST, CLEVEREST, MOST EFFICIENT AND MOST PORTABLE 2 OR 3-VALVE SET IN THE WORLD. EXQUISITELY FINISHED AND FITTED IN A REAL HIDE CASE. Size 15 by 11 by 5 ins.

PRICE £14 14 0

COMPLETE. ALL READY FOR USE AND MARCONI ROYALTIES PAID.

Demonstrations anywhere at any time.

3-Valve Model, guaranteed to work a loud-speaker really well anywhere within 10 miles of a Broadcast Station. Price £18 18s. 0d. No Extras.

H. LLOYD MARSHALL & CO.
8, WESTMORELAND BUILDINGS,
ALDERSGATE ST., E.C.1.
GOOD TERMS TO THE TRADE.

FOR DISPOSAL

Flourishing Wireless Business, 2 miles from Broadcast Station, Main Street, Low Rent. —Box A7, Bertram Day's Advertising Offices, 9-10, Charing Cross, S.W.1.

PANELITE. Will withstand 5,000 Volts, Black Finish. WILL NOT FRACTURE. 6 in. by 6 in. by 3/16 in., 1/-; 7 in. by 5 in., 1/1; 8 in. by 5 in., 1/2; 9 in. by 5 in., 1/4; 9 in. by 6 in., 1/6; 10 in. by 9 in., 2/2; 12 in. by 10 in., 2/9; 14 in. by 12 in., 4/6 post paid. Other sizes and thickness, pro rata.

CROIX L.F. SHROUDED TRANSFORMERS. Ratios 4 to 1 and 5 to 1, 50,000 already in use. New improved, 9/6; Super Model, 11/6, post paid. Send for price list of H.F. Batteries, Headphones, Valves, etc.—**RADIO PANEL CO., Dept. "M," 143, Fetter Lane, London, E.C.4.**

HOW TO BUILD— an Efficient Single-Valve Set By Herbert K. Simpson.

This set is so easy to build and so simple to work that it forms a perfect starting point for the novice. With an outside aerial a little practice will enable quite a number of the B.B.C. and Continental stations to be received with ease. A dull emitter valve can be used without any alterations.

The Ideal Beginner's Set
Will receive 5XX practically anywhere in Great Britain.

PRICE 1/6 (Postage 3d.)

"MODERN WIRELESS" COIL TABLE

sets aside all doubts as to the correct coils to use for Aerial, Anode and Reaction.

PRICE 6d. (Postage 2d.)

Obtainable from principal wireless dealers and through all booksellers or newsgagents—or direct from

RADIO PRESS LTD.
Bush House, Strand, London, W.C.2.

The high-frequency oscillations are rectified, and the low-frequency impulses in the anode circuit of V_3 are passed through the primary T_1 of a low-frequency transformer T_1T_2 , the secondary of which is connected in the combined aerial and grid circuit of the first valve. The first valve thus acts as a low-frequency amplifier, and the amplified L.F. currents in the anode circuit pass through the loud-speaker L.S., which is shunted by a .002 μF capacity condenser C_6 , to by-pass H.F. currents.

Causes of Buzzing

Now a trouble which may be encountered in reflex sets, more particularly in multi-stage H.F. reflex circuits, is their liability to produce buzzing. The low-frequency currents when fed, say, into the grid circuit of the first H.F. amplifying valve, will tend to modulate the H.F. currents applied to the grid circuit of the H.F. amplifying valve. If reaction is present and the valves tend to oscillate, the L.F. currents will modulate the oscillating currents, and these modulated currents, after amplification by the H.F. amplifiers, will, on reaching the detector valve, resolve themselves into L.F. currents, which are once more fed into the grid circuit of the first valve and continue the modulation process. The result is there is a tendency for a

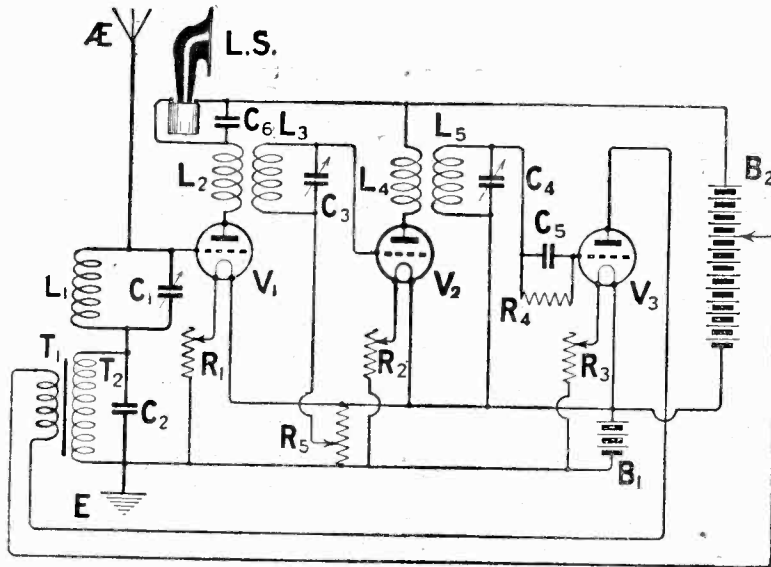

Fig. 4.—A 2 H.F. Reflex Circuit in which the L.F. currents are fed into the grid circuit of the first H.F. Valve.

grid circuit of the dual amplifying valve, for the bottom of the grid circuit of the valve V_1 must be connected as shown, to give the grid a slightly negative potential. To avoid the buzzing and distortion effect, if this is present, it is not possible to stabilise the first valve by potentiometer control, although this is possible in the case of the second valve as indicated.

When there are two stages of H.F. amplification, a more stable and successful method of reflexing

grid of the second valve is given the necessary negative bias by connecting the lower end of the grid circuit to L.T.—. Consequently, if there is any distortion owing to modulation of the H.F. currents, the modulated H.F. output of V_2 is not amplified at high-frequency, thereby increasing the distortion, but is passed on immediately to the detector valve V_3 . Thus the circuit is more stable than that of Fig. 4.

Coil Values

In both the Fig. 4 and Fig. 5 circuits a separate tapping is shown to provide a lower anode voltage for the detector valve than for the other valves.

The H.F. transformers L_2L_3 and L_4L_5 should be chosen to cover the wavelength desired, and for C_1 a .0005 μF condenser would be convenient, while C_2 and C_4 of Fig. 5 may both be .0003 μF . For the broadcast band of wavelengths, Nos. 35 or 50 may be used for L_1 .

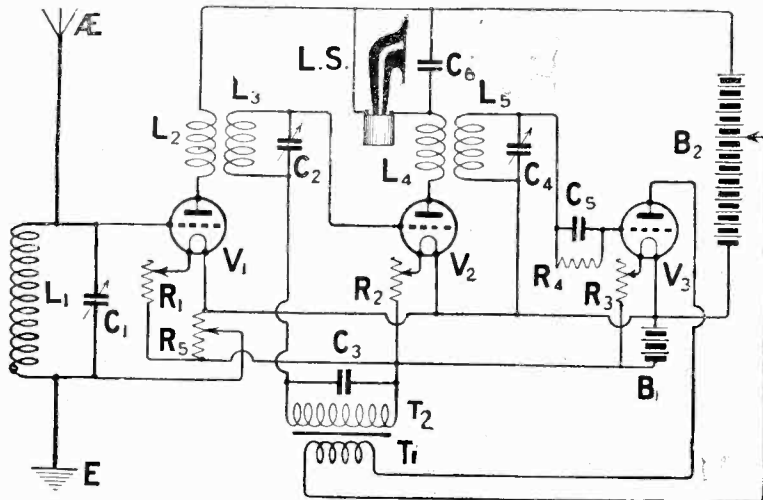

Fig. 5.—This method is to be preferred to the Fig. 4 arrangement.

chain of L.F. reaction, setting up L.F. oscillation, to be established.

If the high-frequency amplifier is working correctly and efficiently, the modulation of H.F. oscillation by L.F. currents will not occur, and the buzzing trouble will be absent. Note that in circuits of this kind one cannot stabilise the

is given in the circuit of Fig. 5, which theoretically should give the same signal strength. Here the L.F. currents are fed into the grid circuit of the second high-frequency amplifying valve, and it is possible to stabilise the grid circuit of the first valve by potentiometer control as shown, whilst the

The next issue of
"The Wireless
Constructor,"

out January 15th, contains
an interesting description of
a Compact Single Valve
Reflex Set by

PERCY W. HARRIS.

Receiving Sets of the Future.

IT is always interesting to consider the trend in development and design of wireless apparatus, and to try to obtain an idea of what wireless receiving sets will be like in the future. Advances in both transmission and reception are being made almost daily by experimenters and research workers alike. The present tendency is towards the use of very short waves, particularly for long-distance work, and the results already achieved are remarkable. Though not yet used for broadcasting purposes, except in a few isolated cases such as the American stations KDKA and WGY, a change may possibly be expected in the future, unless these short wavelengths are monopolised for Government and commercial services. As they become increasingly popular, designers will concentrate more on suitable short-wave receivers. The Supersonic Heterodyne receiver is invaluable for use on short waves, and it is on the lines of this receiver that

most sets of the future will probably be developed. Much important work has been done on Supersonic Heterodyne reception, and readers will do well to refer to the articles on this extremely interesting subject by John Scott-Taggart, F.Inst.P., A.M.I.E.E., which have appeared in *Wireless Weekly* every week since October 22.

An Efficient Short-Wave Tuner.

In the November 19 issue Mr. Percy W. Harris gives full details for the construction and operation of a simple but extremely efficient short-wave receiver under the title of "A Low Loss Tuner for Short Waves." Readers interested in this very fascinating subject will also appreciate the article on "A New 100-Metres Receiver," by Mr. A. D. Cowper, M.Sc., published on December 3. An article in the November 26 issue of *Wireless Weekly* by an American contributor describes a "Short-Wave Adaptor for Existing Sets." This

should provide fruitful matter for the experimenter. This same issue contains, as part of a Special Photogravure Supplement, an exclusive illustrated description of the "Ecole Supérieure" station, contributed by Capt. L. F. Plugge, B.Sc., F.R.Ae.S., F.R.Met.S. Other *Wireless Weekly* features include an article by the inventor giving further details on Oscillating Crystals, and an article, "High-Tension Supply from D.C. Mains," which will prove very useful to amateurs having direct current supply laid on at their homes. The set constructor will find in the December 3 issue a full description of a very useful and efficient Valve-Crystal Tri-coil Receiver by John W. Barber. In addition, full constructional details of a three-valve set, also employing the effective tri-coil principle, are given under the title of "A Self-Contained Three-Valve Receiver," by Herbert K. Simpson, in the issue published on November 26th.



1 1/2 in. WALL INSULATOR
with wood screw
3d. each, 2'6 doz.
4 in. Ditto, with removable spike
6d. each, 4'9 doz.

Specially constructed for clamping on to the earpiece of any Crystal Receiving Set to amplify the incoming speech, etc. It is a real supersensitive instrument that really does its work. Price 17'6. Accessories required are Microphone Transformer R/57D and a 3 volt dry battery.



R57/W
THE "DETECT-AVOX MICROPHONE."

JUST OUT!
NEW 44 PAGE RADIO Catalogue.
MAILED POST FREE FOR 4D. IN STAMPS.



R/37W
HILLIER'S PATENT COMPOUND COUPLED CONDENSER.
The only coupled condenser which provides means for giving a LEAD and LAG to the moving vanes, which is absolutely essential for properly tuning a circuit reacting on a H.F. coil. Capacity 0002 2. Price 25 6.



R/28M. "DEXTRORMER" TRANSFORMER.
Specially designed for use with our "DEXTRAUDION" FULL EMITTER VALVE by Messrs. Radio Instruments, Ltd., and contains all the special features of this famous firm's standard "R.I." Transformer.
Dimensions 3 1/2 by 2 1/2 by 3 1/2 ins.
Weight 1 1/2 lbs. Price 25 -.

ECONOMIC ELECTRIC LTD. Head Office
10, FITZROY SQUARE, LONDON, W. 1.

Showrooms:
103, EUSTON RD., N.W. 1

WHOLESALE ONLY.



Brandes WIRELESS DEALERS—Our new 120 page illustrated list of Radio Parts now ready, showing Trade and Retail Prices. It is yours for the asking.

Large Stocks of Brandes Phones.
Large Stocks of Igranic Coils.

AUTHORISED FACTORS OF ALL N.A.R.M. SPECIALITIES

Complete Sets, Accessories and Component Parts.
We were one of the very first Wholesale Factors of "Wireless," and carry the largest stocks of Radio goods in the British Empire.

THE LARGEST TRADE RADIO LIST EVER ISSUED

STAGGERING PRICES. HUGE STOCKS.
Get To Know Us—It Will Pay You.

Ask for our "CAPITOL" SPEAKER (Retail Price £1 : 11 : 6)
Buy from an Established House.
IMPORTANT—Trade only Supplied.

HOBDAV BROS., LTD.
(Dept. D),
21, 23, 25 & 27, Gt. Eastern Street,
LONDON, E.C.2.
Phone: Clerkenwell 2800 (6 lines).



"Capitol" Speaker

Regular Programmes from Continental Broadcasting Stations

Telephony except when otherwise stated. Corrected up to December 18th, 1924.

Edited by CAPTAIN L. F. PLUGGE, B.Sc., F.R.Ae.S., F.R.Met.S. Strictly Copyright.

WEEK DAYS.

Ref. No.	G. M. T.	Name of Station.	Call Sign and Wave-length.	Situation.	Nature of Transmission.	Closing Time or Approx. Duration.	Approx. Power used.
	a.m.						
1	6.25	Hamburg	— 395 m.	Germany	Time Signal in C.E.T.	5 mins.	700 Watts.
2	6.40	Eiffel Tower	FL 2600 m.	Paris	Weather Forecast	5 mins.	5 Kw.
3	6.55	Munster	— 410 m.	Westphalia	Time Signal in C.E.T.	5 mins.	1.5 Kw.
4	7.05	Lausanne	HB2 850 m.	Switzerland	Weather Report	5 mins.	300 Watts.
5	7.55	Persbureau Vaz Dias	PCFF 2125 m.	Amsterdam	Stocks, Shares and News	10 mins.	2 Kw.
8	9.23	Eiffel Tower	FL 2600 m.	Paris	Time Signal in G.M.T. (Spark)	3 mins.	—
9	9.55	Persbureau Vaz Dias	PCFF 2125 m.	Amsterdam	Stocks, Shares and News	10 mins.	2 Kw.
10	10.00	Eiffel Tower	FL 2600 m.	Paris	Time Signal in Greenwich Sidereal Time (Spark)	5 mins.	—
156	10.00	Radio Wien	— 530 m.	Austria	Concert	Noon	1 Kw.
11	10.30	Lyons	YN 470 m.	Lyons	Gramophone Concert	30 mins.	500 Watts.
12	10.30	Kbel	— 1150 m.	Prague	Exchange quotations	10 mins.	1 Kw.
13	10.44	Eiffel Tower	FL 2600 m.	Paris	Time Signal in G.M.T. (Spark)	3 mins.	—
14	10.55	Eiffel Tower	FL 2600 m.	Paris	Fish Market Quotations—Cotton Exchange.	10 mins.	5 Kw.
15	10.55	Frankfurt	— 470 m.	Frankfurt	Time Signals (spoken) followed by News (in C.E.T.)	5 mins.	1 Kw.
17	11.10	Persbureau Vaz Dias	PCFF 2125 m.	Amsterdam	Stocks and Shares	20 mins.	2 Kw.
18	11.14	Eiffel Tower	FL 2600 m.	Paris	Time Signal in Greenwich Time (Spoken), followed by Weather Forecast.	5 mins.	5 Kw.
20	11.15	Voxhaus	— 430 m.	Berlin	First News Bulletin and Weather Reports.	5 mins.	700 Watts.
19	11.55	Konigsberg	— 463 m.	East Prussia	Time Signal in C.E.T.	5 mins.	1 Kw.
21	11.55	Voxhaus	— 430 m.	Berlin	Time Signal in C.E.T.	5 mins.	700 Watts.
22	11.55	Leipzig	— 454 m.	Germany	Time Signal Relayed from Baven	5 mins.	700 Watts.
23	11.57	Nauen	POZ 3100 m.	Berlin	Time Signal in G.M.T. (Spark)	8 mins.	—
157	12.00 noon	Zurich	— 515 m.	Switzerland	Weather Forecast, Shares and News.	45 mins.	500 Watts.
24	12.00	Persbureau Vaz Dias	PCFF 2125 m.	Amsterdam	Stocks and Shares	8 mins.	2 Kw.
	p.m.						
26	12.15	Geneva	HB1 1100 m.	Switzerland	Lecture	12.45 p.m.	300 Watts.
25	12.30	Kbel	— 1150 m.	Prague	Exchange Quotations	10 mins.	1 Kw.
27	12.30	Lausanne	HB2 850 m.	Switzerland	Weather Reports, Time Signal in C.E.T. and News.	15 mins.	300 Watts.
32	12.30	Radio-Paris	SFR 1780 m.	Clichy	Concert followed by News	2 p.m.	8 Kw.
30	12.45	Stockholm	— 440 m.	Sweden	Weather Forecast	5 mins.	500 Watts.
31	12.45	Persbureau Vaz Dias	PCFF 2125 m.	Amsterdam	Stocks and Shares	10 mins.	2 Kw.
33	1.00	Haeren	BAV 1100 m.	Brussels	Weather Forecast in French and English.	8 mins.	150 Watts.
34	1.00	Munich	— 485 m.	Bavaria	News and Weather Report	10 mins.	1 Kw.
36	1.00	Stockholm	— 440 m.	Sweden	Time Signal	3 mins.	500 Watts.
37	1.15	Voxhaus	— 430 m.	Berlin	Stock Exchange News	5 mins.	700 Watts.
35	1.15	Komarow	— 1800 m.	Czecho-Slovakia.	Stock Exchange and Late News	10 mins.	1 Kw.
40	2.30	Munster	— 410 m.	Westphalia	Stocks, Shares and News	10 mins.	1.5 Kw.
38	2.40	Persbureau Vaz Dias	PCFF 2125 m.	Amsterdam	Stocks, Shares and News	10 mins.	2 Kw.
39	2.45	Eiffel Tower	FL 2600 m.	Paris	Exchange Opening Prices. (Sat. excepted.)	8 mins.	5 Kw.
158	3.00	Zurich	— 515 m.	Switzerland	Hotel Concert, Relayed. (Fri. excepted.)	5 p.m.	500 Watts.
159	3.10	Radio-Wien	— 530 m.	Vienna	Concert	4 p.m.	1 Kw.

Cossor

in their new

Watch your Dealer
test a Cossor Valve
—no need for him
to open the Box

ONE of the principal difficulties that has to be faced by every Valve Manufacturer is to ensure that his Valves reach the user in the same good condition in which they leave the factory.

Many prominent Radio authorities and journals have consistently advocated some form of sealing which would prevent any Valve being used—even for demonstration purposes—before being sold. It has remained for A. C. Cossor, Ltd., to work out a patented packing scheme which is of the utmost benefit to the trade and user alike.

The idea is simplicity itself. The Valve is securely packed in a thick layer of cotton wool, and sealed in its carton. To each of its filament legs has been attached a copper wire brought through the packing and connected to a couple of brass studs on the

TYPES and PRICES.

- P1. For Detector and L.F. use 12/6
- 12. (With Red top) for H.F. use 12/6

WUNCCELL

- DULL EMITTERS**
- Model A. (With resistance in base for use with 2-, 4-, or 6-volt accumulator).

- WK1. For Detector and L.F. use 23/6
- WR2. (With Red top) for H.F. use 23/6

- Model B. (Without resistance) working direct from 2-volt accumulator.

- W1. For Detector and L.F. use 21/-
 - W2. (With Red top) for H.F. use 21/-
- From all Dealers

Advertisement of
A. C. Cossor, Ltd.,
Highbury Grove,
London, N.5.

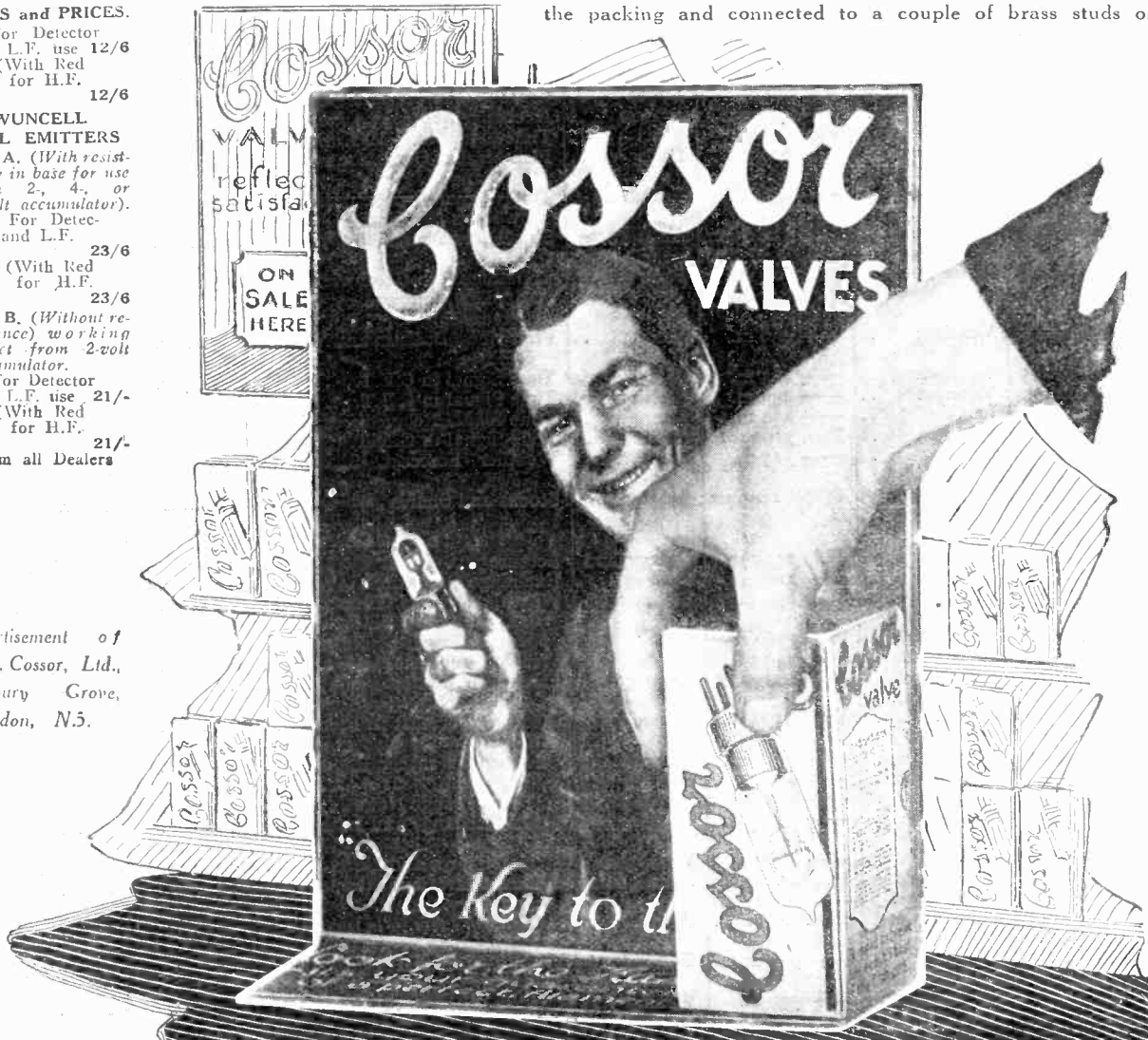

Valves

sealed cartons

exterior of the carton. It will be obvious that if these two studs are placed in circuit with a flash lamp and battery the current will pass through the filament and—completing the circuit—cause the flash lamp to light. If, on the other hand, the filament is broken, the current cannot pass, and the lamp will not light. This idea is incorporated in an electrical Showcard supplied to all Dealers. All that he has to do is to pick up the Cossor sealed Carton containing the Valve, and place its studs in contact with two metal strips on the Showcard. If the Valve is in order the miniature lamp behind the showcard lights up—he need not break the seal at all.

If you want to be sure of getting a Valve with a full life, therefore, be sure you choose a Cossor—the only one that is guaranteed a safe passage from factory to user.

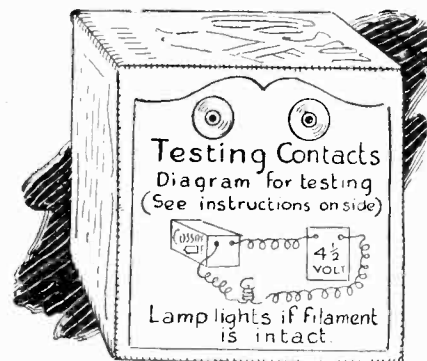

Above: The end of the Carton showing the metal contacts and circuit diagram of the Showcard.
Below: The new Cossor box—every Cossor Valve irrespective of type is being packed in this method.

Every Purchaser gets an unused Cossor Valve—

Seven features you cannot get with any other Valve

1. An arched filament which entirely supports its own weight and which does not require springs or other forms of tension to prevent it from sagging. This makes for long life for the Valve.
2. A hood-shaped Grid—scientifically built up on stout metal Grid band—with every turn of its wire anchored in three distinct positions. This guarantees complete freedom from microphonic noises.
3. A hood-shaped Anode completely enclosing the Grid and filament and thereby making use of practically the whole of the electron stream. This ensures greater sensitiveness.
4. A special type of Valve—known as the Cossor P.2 (the Valve with the red top)—which has been specially designed for high-frequency amplification. This means that Stations—hitherto out of your reach—can now be picked up with certainty.
5. A unique method of testing Cossor Valves by which every Valve is given a complete and costly series of tests before being issued. This ensures that Valves which, superficially, might look correct must conform to a definite scientific standard or be rejected.
6. And now a Dull Emitter which glows at a temperature which is practically invisible during daylight. The Wuncell is available with characteristics to match exactly the P.1 and the P.2. It operates at 1.8 volts and requires so little current that a small portable accumulator will last the average 3 valve Loud Speaker Set a fortnight on a charge at a cost of a few pence.
7. Finally, the new patent Cossor packing system—a method which will revolutionise the industry—is a genuine effort on the part of the manufacturers to strike out of the rut in the honest endeavour to see that Cossor Valves arrive at their ultimate destination in an absolutely new and unused condition.

Interesting and useful literature on the Cossor Valve will be sent post free to all who apply. In any case before you purchase a Dull Emitter be sure you read our large Folder containing a full description of the many exclusive features of the Wuncell. A post-card brings it free.

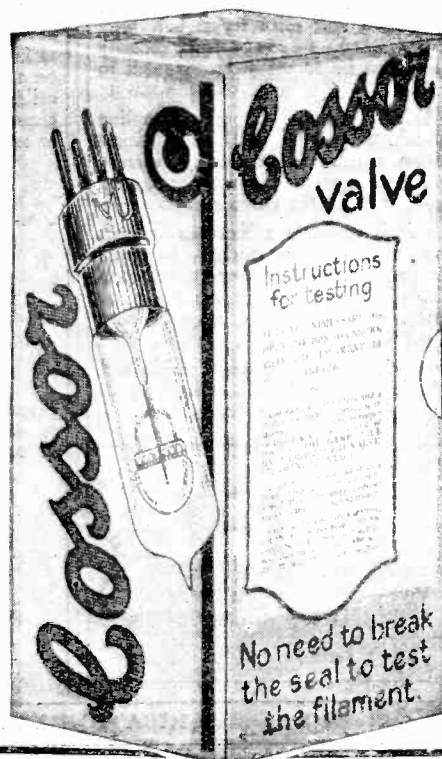

POLAR RADIO COMPONENTS



PRICE
15/-

POLAR RESISTANCE CAPACITY COUPLING UNIT

Distortion in wireless reception has been a general cause of complaint in the past and is difficult to eliminate as long as the only available method of intervalve coupling is that of the iron core transformer.

Iron is the chief trouble in this connection. But, fortunately, we are no longer at the mercy of iron.

It is well known that resistance capacity coupling between stages of low-frequency amplification eliminates distortion. Perfectly pure reception can be obtained by this method.

When you are buying an iron core transformer, you may be buying distortion, and paying a stiff price for it too. Why do this, when resistance capacity coupling can be as easily incorporated in your set?

The Polar Resistance Capacity Coupling Unit, which enables you to eliminate distortion, consists of an anode resistance, a grid leak and a Dubilier condenser specially built for the purpose.

The unit is perfectly self-contained, and, having four clearly marked terminals corresponding to the four transformer terminals, it lends itself admirably to straightforward wiring, as may be seen from the illustration below.

If you wish to obtain pure music and speech, incorporate R.C.C. units in your set and give your loud-speaker a chance.

A leaflet giving wiring diagrams accompanies every unit.

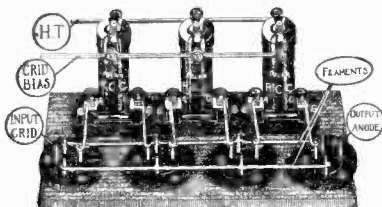

POLAR BOBBIN RHEOSTAT

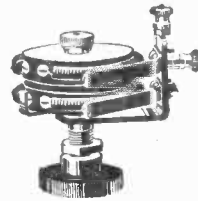

You would never dream of buying a coil-holder with permanently fixed coils. The reason is obvious. For different wavelengths, different coils are used.

Plug-in coils can be obtained to cover a wide range of wavelengths. Hitherto, rheostats were suitable for use with only one type of valve. With the advent of the Polar Bobbin Rheostat, the entire range of receiving valves and varying voltages is efficiently covered.

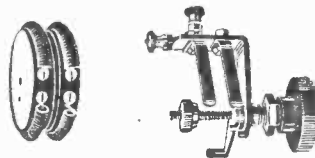

In incorporating in your set a rheostat-holder you employ the same principle as in the case of a coil-holder. To receive on a different wavelength you change your coils. To receive on a different valve you change your bobbin. There is a bobbin to suit every valve and voltage.

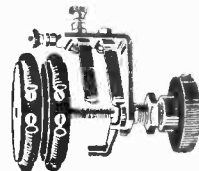

Five types of bobbins are available, designed to suit the requirements of single valves or combination of valves.

TYPE A	5 ohms	Variable.
" B	10 "	" "
" C	15 "	" "
" D	5 "	Fixed.
" D	30 "	Variable.
" E	10 "	Fixed.
" E	15 "	Variable.

Bobbin 2s. 9d. Holder 2s. 9d.
Complete 5s. 6d.

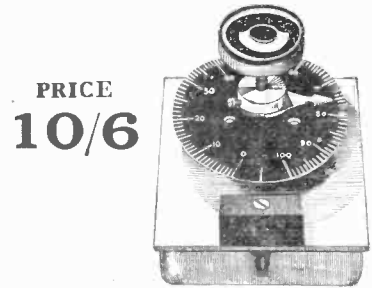

PRICE
10/6

POLAR VARIABLE CONDENSER

A few years ago Radio Communication Company were confronted by a very important question of providing their Marine Operators with a condenser which would give a wide open scale over the lower limits of tuning, and which would not require an additional micrometer condenser in parallel.

It is well known that in a tuned oscillatory circuit one should use as much inductance and as little capacity as possible.

The ordinary vane condenser could not be utilised, as most of its capacity is cramped over the lower section of the scale, with the result that a small knob adjustment will give a large capacity change when it is not wanted.

In order to obtain a high efficiency of tuning and to meet the exacting demands of marine work, a condenser had to be designed which would reverse the above effect and give the operator a wide open scale at the business end of the condenser.

After a good deal of research and numerous exacting tests, the Polar Variable Condenser was produced.

There are over a quarter of a million of Polar Condensers now in use.

The secret of its popularity lies in the fact that a wide open scale giving a uniform variation of wave frequency is combined with wide capacity limits, high insulation, complete metallic screening, robust construction and small overall dimensions (see illustration below, which shows a Polar Condenser mounted side by side with an air condenser of the same capacity).

There are five standard capacities available: .001, .0005, .0003, .00025 and .0002 microfarads.

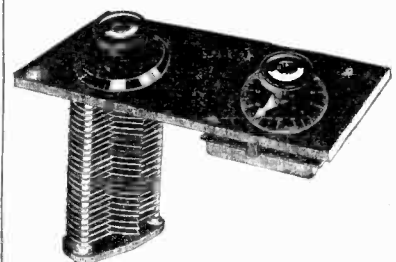

RADIO COMMUNICATION CO., LTD., 34-35, NORFOLK STREET, STRAND, W.C.2.

Ref. No.	G. M. T.	Name of Station.	Call Sign and Wave-length.	Situation.	Nature of Transmission.	Closing Time or Approx. Duration.	Approx. Power used.
----------	----------	------------------	----------------------------	------------	-------------------------	-----------------------------------	---------------------

WEEK DAYS (Contd.)

42	p. m. 3.30	Frankfurt	— 470 m.	Germany	Light Orchestra	5 p. m.	1 Kw.
43	3.30	Konigsberg	— 463 m.	East Prussia	Light Orchestra	1 hour.	1 Kw.
44	3.30	Voxhaus	— 430 m.	Berlin	Concert, followed by News	5.30 p. m.	700 Watts.
45	3.30	Munich	— 485 m.	Bavaria	Concert	4.30 p. m.	1 Kw.
46	3.30	Leipzig	— 454 m.	Germany	Concert	5 p. m.	700 Watts.
47	3.35	Eiffel Tower	FL 2600 m.	Paris	Exchange Quotations (Sat. excepted).	5 mins.	5 Kw.
48	3.55	Persbureau Vaz Dias.	PCFF 2125 m.	Amsterdam	Stock Exchange and News	10 mins.	2 Kw.
49	4.00	Kbel	— 1150 m.	Prague	Shares and News	10 mins.	1 Kw.
160	4.00	Breslau	— 418 m.	Silesia	Light Orchestra	5 p. m.	1.5 Kw.
51	4.30	Radio-Paris	SFR 1780 m.	Clichy	Concert preceded and followed by News.	5.45 p. m.	8 Kw.
52	4.30	Eiffel Tower	FL 2600 m.	Paris	Exchange Closing Prices (except Saturday).	8 mins.	5 Kw.
53	4.45	Stuttgart	— 443 m.	Wurtemberg	Concert followed by Weather Report (Saturdays excepted).	6 p. m.	1 Kw.
54	5.00	Radio-Belg.	SBR 265 m.	Brussels	Concert followed by News	6 p. m.	2.5 Kw.
177	5.00	B. reclona	EAJ1. 325 m.	Spain	Tests	7.00 p. m.	650 Watts.
161	5.30	Munich	— 485 m.	Bavaria	Light Orchestra	6.30 p. m.	1 Kw.
55	5.55	Lausanne	HB2 850 m.	Switzerland	Weather Report	5 mins.	300 Watts.
162	6.00	Eiffel Tower	FL 2600 m.	Paris	Concert followed by News Bulletin	6.55 p. m.	5 Kw.
57	6.30	Kbel	— 1150 m.	Prague	Concert and News	7.30 p. m.	1 Kw.
58	7.00	Eiffel Tower	FL 2600 m.	Paris	General Weather Forecast	8 mins.	5 Kw.
60	7.00	Radio-Wien	— 530 m.	Vienna	Concert	9 p. m.	1 Kw.
61	7.00	Konigsberg	— 463 m.	East Prussia	Concert and News	8.30 p. m.	1 Kw.
62	7.00	Hamburg	— 395 m.	Germany	Concert and Late News	9.50 p. m.	700 Watts.
63	7.00	Stuttgart	— 443 m.	Wurtemberg	Concert and News	9.30 p. m.	1 Kw.
179	7.00	Radio-Iberica	RI 392 m.	Madrid, Spain	Concert and News	8.00 p. m.	3 Kw.
66	7.15	Lausanne	HB2 850 m.	Switzerland	Concert (Monday excepted)	9.30 p. m.	300 Watts.
64	7.15	Zurich	— 515 m.	Switzerland	Concert followed by Late News	10 p. m.	500 Watts.
65	7.15	Leipzig	— 454 m.	Leipzig	Concert and News	8.35 p. m.	700 Watts.
67	7.30	Frankfurt	— 470 m.	Frankfurt	Concert and News	10 p. m.	1 Kw.
59	7.30	Munster	— 410 m.	Westphalia	Concert followed by News	9 p. m.	1.5 Kw.
72	7.30	Voxhaus	— 430 & 505	Berlin	Concert followed by News and Weather Report.	9.15 p. m.	0.7 and 1.5 Kw.
73	7.30	Munich	— 485 m.	Bavaria	Concert and News	8.40 p. m.	1 Kw.
69	7.45	Breslau	— 418 m.	Silesia	Concert	9 p. m.	1.5 Kw.
164	8.00	Radiofonica Italiana.	— 422 m.	Rome	Concert followed by News	9.30 p. m.	4 Kw.
74	8.15	Radio-Belg.	SBR 265 m.	Brussels	Concert preceded and followed by News.	10.10 p. m.	2.5 Kw.
75	8.30	Ecole. Sup. des P. & Tg.	FPTT 450 m.	Paris	Concert, sometimes preceded by Lecture, usually outside broadcast.	9 p. m.	500 Watts.
76	8.30	Radio-Paris	SFR 1780 m.	Clichy	Detailed News Bulletin	9 p. m.	8 Kw.
77	9.00	Radio-Paris	SFR 1780 m.	Clichy	Time Signal followed by Concert	9.50 p. m.	8 Kw.
78	9.30	Radio-Iberica	— 392 m.	Madrid	Concert, Advertisements	Midnight	3 Kw.
79	10.00	Eiffel Tower	FL 2600 m.	Paris	Time Signal in Greenwich Sidereal Time (Spark).	5 mins.	—
80	10.10	Eiffel Tower	FL 2600 m.	Paris	General Weather Forecast	5 mins.	5 Kw.
81	10.44	Eiffel Tower	FL 2600 m.	Paris	Time Signal in G.M.T. (Spark)	3 mins.	—
82	11.57	Nauen	POZ 3100 m.	Berlin	Time Signal in G.M.T. (Spark)	3 mins.	—

SUNDAYS

83	a. m. 7.00	Frankfurt	— 470 m.	Germany	Morning Prayer	1 hour	1 Kw.
85	8.00	Leipzig	— 454 m.	Germany	Morning Prayer	1 hour	700 Watts.
105	8.00	Konigsberg	— 463 m.	E. Prussia	Morning Prayer	8.45 a. m.	1 Kw.
86	9.00	Komarow	— 1800 m.	Czecho-Slovakia.	Sacred Concert	1 hour	1 Kw.
87	9.23	Eiffel Tower	FL 2600 m.	Paris	Time Signal in Greenwich Mean Time (Spark).	3 mins.	—
166	9.30	Munich	— 485 m.	Bavaria	Sacred Concert	10.30 a. m.	1 Kw.
89	10.00	Eiffel Tower	FL 2600 m.	Paris	Time Signal in Greenwich Sidereal Time (Spark).	5 mins.	—
90	10.00	Kbel	— 1150 m.	Prague	Classical Music	1 hour	1 Kw.
92	10.00	Radio-Wien	— 530 m.	Vienna	Concert	2 hours	1 Kw.
93	10.30	Lyons	YN 470 m.	Lyons	Gramophone Records	11 a. m.	500 Watts.
94	10.30	Stuttgart	— 443 m.	Wurtemberg	Classical Concert	1 hour	1 Kw.
95	10.44	Eiffel Tower	FL 2600 m.	Paris	Time Signal in G.M.T. (Spark)	3 mins.	—

Ref. No.	G. M. T.	Name of Station.	Call Sign and Wave-length.	Situation.	Nature of Transmission.	Closing Time or Approx. Duration.	Approx. Power used.
SUNDAYS (contd.)							
96	a.m. 10.50	Konigswusterhausen.	LP 2800 m.	Berlin	Concert	11.45 a.m.	6 Kw.
97	10.55	Eiffel Tower	FL 2600 m.	Paris	Fish Market Quotations, followed by Weather Report.	12 mins.	5 Kw.
91	11.00	Breslau	— 418 m.	Silesia	Concert	1 hour	1.5 Kw.
98	11.00	Stockholm	— 440 m.	Sweden	Divine Service	12.15	500 Watts.
101	11.57 p.m.	Nauen	POZ 3100 m.	Berlin	Time Signal in G.M.T. (Spark)	3 mins.	—
102	12.45	Radio-Paris	SFR 1780 m.	Clichy	Concert, followed by News	2.00 p.m.	8 Kw.
104	3.00	Breslau	— 418 m.	Silesia	Children's Stories	3.45 p.m.	1.5 Kw.
105	3.00	Stuttgart	— 443 m.	Wurtemberg	Light Orchestra	5.00 p.m.	1 Kw.
107	3.00	Frankfurt	— 470 m.	Germany			1 Kw.
167	3.00	Zurich	— 515 m.	Switzerland	Local Hotel Concert	5.00 p.m.	500 Watts.
108	3.00	Munich	— 485 m.	Bavaria	Concert	5.00 p.m.	1 Kw.
106	3.10	Radio-Wien	— 530 m.	Vienna		4.00 p.m.	1 Kw.
168	3.30	Konigsberg	— 463 m.	E. Prussia	Light Orchestra	4.30 p.m.	1 Kw.
169	3.30	Voxhaus	430 & 505 m.	Berlin	Light Orchestra	5.15 p.m.	1 Kw.
170	3.30	Leipzig	— 454 m.	Germany	Light Orchestra	5.00 p.m.	700 Watts.
171	4.00	Frankfurt	— 470 m.	Germany	Children's Corner	5.00 p.m.	1 Kw.
172	4.45	Stuttgart	— 443 m.	Wurtemberg	Concert	6.00 p.m.	1 Kw.
110	4.45	Radio-Paris	SFR 1780 m.	Clichy	Concert, followed by News	1 hour	8 Kw.
111	5.00	Radio-Belg.	SBR 265 m.	Brussels	Concert	1 hour	2.5 Kw.
180	5.00	Barcelona	EAJI 325 m.	Spain	Tests	7.00 p.m.	650 Watts.
112	6.00	Eiffel Tower	FL 2600 m.	Paris	Concert, followed by News	1 hour	5 Kw.
114	7.00	Radio-Wien	— 530 m.	Vienna	Concert	8.30 p.m.	1 Kw.
115	7.00	Stockholm	— 440 m.	Sweden	Concert	10.00 p.m.	500 Watts.
118	7.00	Konigsberg	— 463 m.	E. Prussia	Concert	9.00 p.m.	1 Kw.
119	7.00	Hamburg	— 395 m.	Germany	Concert	9.00 p.m.	700 Watts.
120	7.00	Eiffel Tower	FL 2600 m.	Paris	General Weather Forecast	8 mins.	5 Kw.
125	7.00	Stuttgart	— 443 m.	Wurtemberg	Concert	9.15 p.m.	1 Kw.
173	7.00	Frankfurt	— 470 m.	Germany	Entertainment provided by Frankfurter Zeitung.	10.00 p.m.	1 Kw.
121	7.15	Lausanne	HB2 850 m.	Switzerland	Concert	8.30 p.m.	300 Watts.
122	7.15	Zurich	— 515 m.	Switzerland	Concert	10.00 p.m.	500 Watts.
123	7.15	Leipzig	— 454 m.	Germany	Symphony Concert	8.40 p.m.	700 Watts.
116	7.00	Munster	— 410 m.	Westphalia	Classical Concert	9.00 p.m.	1.5 Kw.
124	7.30	Breslau	— 418 m.	Silesia	Light Orchestra	9.00 p.m.	1.5 Kw.
174	7.30	Munich	— 485 m.	Bavaria	Concert	8.30 p.m.	1 Kw.
126	7.40	Ned. Seintoesl Fabriek.	NSF 1050 m.	Hilversum	Concert	10.10 p.m.	1 Kw.
176	8.00	Copenhagen	— 750 m.	Denmark	Concert, followed by News	9.30 p.m.	2 Kw.
175	8.30	Radiofonica Italiana.	— 422 m.	Rome	Concert, followed by Late News	9.30 p.m.	4 Kw.
127	8.30	Radio-Belg.	SBR 265 m.	Brussels	Concert, followed by News	10.10 p.m.	2.5 Kw.
128	8.30	Radio-Paris	SFR 1780 m.	Clichy	Detailed News Bulletin	9.00 p.m.	8 Kw.
129	8.30	Ecole Sup. des P. et Tgs.	FPTT 450 m.	Paris	Concert or Lecture. May begin 15 mins. earlier or later.	10.30 to 12 p.m.	500 Watts.
130	9.00	Radio-Paris	SFR 1780 m.	Clichy	Concert, followed by Dance Music.	10.00 p.m.	8 Kw.
131	9.30	Petit Parisien	— 340 m.	Paris	Concert (Items announced in English as well as French.)	11.30 p.m.	400 Watts.
132	9.40	Radio-Iberica	— 392 m.	Spain	Concert	midnight	3 Kw.
133	10.00	Eiffel Tower	FL 2600 m.	Paris	Time Signal in Greenwich Sidereal Time (Spark).	3 mins.	—
134	10.44	Eiffel Tower	FL 2600 m.	Paris	Time Signal in G.M.T. (Spark)	3 mins.	—
135	11.57	Nauen	POZ 3100 m.	Berlin	Time Signal in G.M.T. (Spark)	8 mins.	—
SPECIAL DAYS.							
137	p.m. 4.00	Lausanne	HB2 850 m.	Switzerland	Mon. Children's Stories	1 hour	300 Watts.
180	5.30	Belgrade	HFF 1650 m.	Serbia	Tues., Thurs., Sat. Tests	1 hour	500 Watts.
140	5.15	Zurich	— 515 m.	Switzerland	Mon., Wed., Fri. Children's Corner	5.50 p.m.	50 Watts.
141	5.15	Zurich	— 515 m.	Switzerland	Thurs. Lecture	30 mins.	500 Watts.
142	5.40	Ned. Seintoesl Fabriek.	NSF 1050 m.	Hilversum	Mon. Children's Hour	6.40 p.m.	1 Kw.
146	7.00	Svenska	— 470 m.	Stockholm	Wed. Concert	10 p.m.	300 Watts.
147	7.00	Stockholm	— 440 m.	Sweden	Fri., Sat. Concert	10 p.m.	500 Watts.

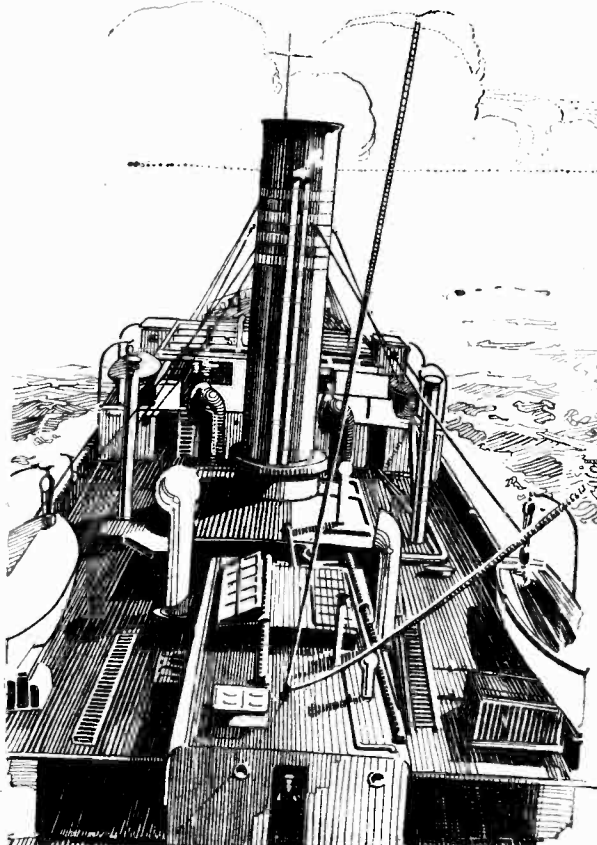

“Act as judgment says is proper”

“If to my Starboard
 ✧ ✧ ✧ red appear.
 It is my duty to keep
 ✧ ✧ ✧ ✧ ✧ clear.
 To act as judgment
 ✧ ✧ says is proper
 To Port or Starboard
 Back or Stop her-”

*A rule of the road for
 preventing collision
 at sea.*



THE “rule of the road” at sea calls upon the officer in charge of the ship in the foreground to “act as judgment says is proper” in avoiding collision with the approaching vessel.

To be able to form sound judgment and act on it promptly is one of the essential qualities of the sailor; and whether one is driving a car, playing billiards, or catching the morning train good judgment is equally necessary.

* * * *

Consider the components you fit to your wireless set.

Upon them depends not only the success of the whole set but also your reputation as a wireless expert.

Your judgment tells you that if you choose the products of a firm which has a long specialised experience and a reputation for “making a sound engineering job of things” you will have chosen wisely and well.

It is a mistake to suppose that one make of condenser is much the same as another, and it is a mistake to believe that your set can give the best results if your condensers and resistances are of the just-as-good variety.

Act as judgment says is proper—

Specify Dubilier.

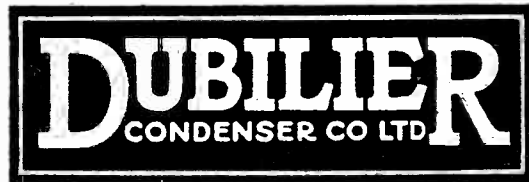

Ducon Works, Victoria Rd., North Acton, London, W.3. E.P.S:39

In replying to advertisers, use COUPON on last page

A.J.S.

The A.J.S. Mark stands for QUALITY

Three examples from the famous range of A.J.S. Wireless Products:—

THE "UNITOP" CABINET RECEIVER
Forms top section of "Unit System" Cabinet, and contains A.J.S. 4-Valve Receiver. Complete in itself, it may be converted into a beautiful pedestal cabinet by subsequent purchase of first section containing special A.J.S. Loud Speaker. Used alone, the "Unitop" is a compact and attractive piece of furniture and a highly efficient Receiver, easily portable for outdoor functions. In Mahogany or Light, Dark, or Wax-polished Oak. Complete with all accessories, ready for use. **30 Guineas.** (Without accessories, £24 10 0)

A.J.S. LOUD-SPEAKER.
Accurately proportioned non-resonant horn, giving correct acoustic properties. True reproduction and extreme sensitivity without distortion. With Metal horn and plated fittings, **£4 15s.** With Oak or Mahogany horn and plated fittings, **£5 10s.**

A.J.S. 4-VALVE RECEIVER.
Polished walnut cabinet, plated fittings, filament resistance to each valve and switch for L.F. valves. Complete with four valves, 100 v. H.T. battery, 8 amp. hour 6 v. L.T. battery, lead-in tube, aerial wire, insulators and Brandes "Matched Tone" Headphones. Complete set, **£27 5s.** Panel only, **£20 5s.**

Your nearest A.J.S. dealer will show you these and other A.J.S. instruments, including the 2 and 3-Valve Receivers, the "Unit System" 4-Valve Cabinet, and the Pedestal 4-Valve Cabinet. Send postcard for free illustrated list.

A. J. STEVENS & CO (1914) LTD

WIRELESS BRANCH
WOLVERHAMPTON

Phone 1557. Wireless Call Sign: 5RL. Grams: "Reception, Wolverhampton."



Ref. No.	G. M. T.	Name of Station.	Call Sign and Wave length.	Situation.	Nature of Transmission.	Closing Time or Approx. Duration.	Approx. Power used.
SPECIAL DAYS (contd.).							
148	p.m. 7.40	Smith and Hooghardt	PA5 1050 m.	Amsterdam	Wed. Concert	9.40 p.m.	500 Watts.
149	8.10	Middelraad ..	PCMM 1050 m.	Ymuiden ..	Sat. Concert	9.40 p.m.	300 Watts.
150	8.40	Ned. Radio In.	PCGG 1070 m.	The Hague	Mon. Concert	10.10 p.m.	1.3 Kw.
151	8.40	Amsterdam ..	PX9 1050 m.	Holland ..	Tues. Concert	10.40 p.m.	600 Watts.
152	8.40	Ned. Seintoesl Fabriek	NSF 1050 m.	Hilversum	Fri. Concert	9.40 p.m.	1 Kw.
153	9.00	Le Matin ..	SFR 1780 m.	Paris ..	2nd & 4th Sat. of mth. Special Gala Concert	10.50 p.m.	10 Kw.
154	9.30	Petit Parisien	— 340 m.	Paris ..	Tues., Thur. Concert (Items announced in English as well as French).	11.30 p.m.	400 Watts.
155	10.00	Radio-Paris ..	SFR 1780 m.	Clichy ..	Wed., Fri. Dance Music ..	10.45 p.m.	8 Kw.

WIRELESS IN THE U.S. ARMY.



The complete wireless installation for a battalion can be carried by two men.

"A Loose-Coupled Single-Valve Receiver."

SIR,—With a view to economy in current consumption, I have been lately trying several crystal one-valve reflex circuits, unfortunately in my case without any great success. Looking back to my October number of MODERN WIRELESS, I decided to try the loose-coupled single valve reaction receiver described by S. G. Rattee.

I have obtained wonderful results with this receiver, and it is to be heartily recommended to those who cannot go to more than one valve.

With outside aerial, at 40 miles south of London, I get very loud signals from London and Bournemouth broadcast. All the Paris stations, Radiola, Petit Parisien, Postes and Télégraphes, are loud and clear. Brussels is very good. Madrid is clear, but rather difficult to tune in. On Sunday evening I listened to an opera broadcast apparently from Berlin, not loud but clear. I have also heard the Italian announcer at the Rome station.

On an inside aerial, 80 ft. across ceiling, I get both London and Bournemouth without difficulty.—Yours truly,

NORMAN GUTTERIDGE.
Haslemere.

ELECTROSTATIC REACTION—AN EXPLANATION.

Owing to an unfortunate error, certain corrections in the above-named article which should have been made were not included. In column 1 line 32 and column 2 line 16 the words "audio-frequency" should have read "radio-frequency" in each case.



Panel Coil Holder
A TWO-COIL holder for panel mounting which will appeal to many amateur constructors has been issued by Messrs. Goswell Engineering Co., Ltd., at a very moderate price which is hardly more than that of a couple of plain coil plugs.

The sample submitted for our examination was in two parts, mounted on a card, a drilling template being also supplied. Both

the fixed coil plug and the bearing-posts for the swinging coil are fixed to the panel by a couple of small bolts apiece: these bolts are also utilised for electrical connections. Thus no untidy flex is visible, to give unwanted stray capacity couplings, which we consider is a strong point in the favour of this type of mounting.

The moving coil swings on a horizontal axis in bearings in the pillars mentioned. These bearings

can be tightened up by small screws, to compensate for wear, and so as to make the holder stiff enough to carry the largest sizes of plug-in coils. A 4 in. bent handle with insulating knob controls the moving coil. Since the former is connected electrically with one end of the coil, connections should be arranged so that this is near earth potential for H.F. energy, otherwise hand-capacity effects may be troublesome.

Myers Valves
Practically Unbreakable

"The World On Your Dial"

improve, improve, improve

Day by day experiment carried to exhaustion has added many little refinements to the MYERS. Its construction from the day they were first obtainable has undergone a change here and there—briefly the MYERS you bought one year ago, unsurpassed as it was, is to-day second only to the product of the present day. The long range reception which amateurs have achieved with MYERS is the potential reward of every Receiver fitted with MYERS—in a word "Radio on Wings."

NEW TYPE MYERS VALVES

The long range and the long life valve are obtainable from our agents or direct from us.

- LONDON.**—Dull Emitter Valve Co., 83, Pelham Street, Kensington, S.W.7.
- MANCHESTER.**—R. Davies & Sons, Wireless Depot, Bilsberry Street.
- NEWCASTLE.**—Charles Bailey, 26, Cloth Market.
- LIVERPOOL.**—Apex Electrical Supply, 59, Old Hall Street.
- GLASGOW.**—Milligan's Wireless Co., Ltd., 50, Sauchiehall Street.
- YORKSHIRE.**—Messrs. Radio Production, 107, Portland Crescent, Leeds.
- BRISTOL.**—Bristol Wireless Co., Radio House, Queens Road.
- TAUNTON.**—A. Montague Cooper, 20, East Street.
- WINCHESTER.**—Watson & Childs, 7, City Road.

A practical suggestion.

In the receiver designed by Mr. John W. Barber, "A Long Distance Single Valve Receiver," described in the December issue of "Modern Wireless," it will be observed that arrangements are made for the set to accommodate both the four-pin valve and the MYERS. The special mounting peculiar to the MYERS is an essential factor towards its remarkable achievements in long range reception. Try the MYERS as suggested practically and your next receiver will be built to incorporate MYERS valves only.

Myers Practically
Unbreakable
Valves

CUNNINGHAM & MORRISON
WINDSOR HOUSE, VICTORIA STREET,
LONDON, S.W.1 Telephone: Victoria 827.

On test, the quality of the insulating material proved to be suitable, and the mechanical construction and finish generally were satisfactory.

A Finely Variable Grid Leak

We have received from J. Anderson a couple of samples of an interesting type of variable grid leak, which is of rather an unusual kind, and appears to have much promise. Superficially, this resembles closely an ordinary filament resistance, of the circular wire-spiral type, but in place of the familiar spiral of resistance-wire, there is a thin rod of black resilient material which provides the resistance element. The usual type of spring contact-finger rubs on this, and includes more or less of the resistance element in the leak circuit according to its adjustment. There are positive stops at each end of travel of the finger, and small terminals for connections. The whole is adapted for mounting behind the panel (where it occupies a space of $1\frac{1}{2}$ in. diameter by 1 in. deep to clear terminals, etc.), by two small screws, which also fix in position a circular stamped brass shield for the resistance rod. An ordinary large ebonite knob and

pointer are provided outside the panel, for control.

On test, the range with the one instrument was from about 0.15 to 6 megohms; of the other from 12 to just under 0.15 megohms. The values for a given setting appeared to be strictly reproducible, and there were no signs of creep, even with a current of many microamperes passing through the rod. In actual reception, the adjustment was quite silent, and capable of very fine setting. Thus with a D.E. valve the closest control over oscillation was obtained in single-valve long-range working.

One criticism must be made as to general design: the clearance between the metal parts is extremely narrow—at one point only $\frac{1}{8}$ th in.—so that the casual capacity across the leak is actually by measurement nearly two micro-microfarads, in place of the $\frac{1}{2}$ or less $\mu\mu\text{F}$ of the ordinary straight fixed type of grid leak. As this represents a bypass reactance for H.F. energy of only 100,000 ohms, in parallel with the ohmic leak, on the broadcast waves, it might be advisable in some cases to reduce this by allowing greater clearance between metal parts at

the two ends of the leak path. In ordinary valve reception it represents merely an inconsiderable addition to the general inevitable casual capacities.

Apart from this point, it would appear as if this instrument represents a real step in advance towards the perfect variable grid leak.

We gather that a variable anode resistance of the same general type is to be placed on the market shortly by the same makers.

A Variable Grid Leak

Messrs. Lissen, Ltd., have sent for test a sample of their latest pattern of variable grid leak. This is of the well-known single-hole-fixing type; it is about $\frac{1}{2}$ in. diameter by $1\frac{1}{2}$ in. long beneath the panel, and has soldering-tags for connections with a small knob above the panel for control. The space occupied, therefore, is but small. Appearance and finish are of a high order.

On test, this gave a range of resistances from about $\frac{1}{4}$ to 10 megohms, and the values appeared to be reproducible. The operation, in actual valve reception, was smooth and silent, so that excellent control was obtained over

THE SHIPTON NEW TYPE Strip Rheostat & Potentiometer

You buy good Valves—sensitive to perfect filament control—therefore build into your receivers rheostats which can control them.

THE MOST PERFECT RHEOSTAT YET INTRODUCED

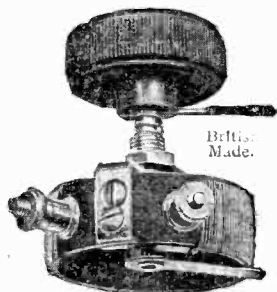

is the SHIPTON. They are mechanically sound. A specially designed spindle gives one-hole fixing and incorporates a tension spring which ensures perfect electrical contact at all times; terminal connections are provided. The 7-ohm Model is fitted with a fuse, which little device may save you the cost of an expensive valve. In operation they are noise free—quite an important consideration.

As used in the 7-Valve T.A.T. Receiver described by Mr. John Scott-Taggart.

- SHIPTON New Type STRIP RHEOSTAT 7 ohm (with fuse) 3/-
 - SHIPTON New Type STRIP RHEOSTAT 30 ohm 3/-
 - SHIPTON New Type STRIP RHEOSTAT 60 ohm 3/-
 - SHIPTON POTENTIOMETER 600 ohm 4/6
- Packed in neat linenette boxes.

SHIPTON Products are obtainable from all Dealers.

E. SHIPTON & CO., LTD.

37, TOTHILL STREET, WESTMINSTER, S.W.1.
 Telephone: Victoria 7. Telegrams: "Rentfones, Parl."
 Also at 14, KING STREET, COVENT GARDEN, W.C.2.

Trade Enquiries Invited.

The SHIPTON New Type VARIABLE GRIDLEAK

Here is another SHIPTON efficient unit. Mechanically perfect and thoroughly tested by experts to secure maximum and uniform efficiency.

British Made

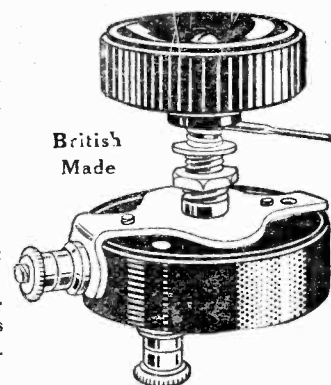

CHARACTERISTICS.

- Silent in operation. Constant under different settings.
- Can be calibrated accurately.
- Reliable under all conditions 300,000 ohms to 6 Mega..ms.

PRICE 3/-

You Cannot afford—it is good reception you want—to risk an unreliable grid leak. Be certain of what you are buying. Get a SHIPTON—you can't go wrong.

Shipton Filament Controls are highly efficient. Get them from your local dealer, or direct giving your dealer's name and address.

oscillation and back-lash in the reception of faint telephony on the single valve. Whilst in a necessarily brief trial it cannot be determined to what extent such an instrument will retain its qualities in practical daily use, from favourable experience with an earlier, larger pattern of Lissen variable grid leak, the writer would be inclined to recommend this instrument for more extended trial.

A New Galena Crystal

A galena crystal of a somewhat unexpected type, but one which shows excellent sensitive properties on actual trial, will shortly be placed on the market by A. Hinderlich. The specimens submitted for test appeared to be merely ordinary inactive cubically crystalline galena, in large smooth-faced crystals of the type which occurs in nature, and which generally shows little or no sensitiveness when tested in the ordinary way. An odd sensitive spot may sometimes be found at a corner or fault in the crystalline structure; but in general, large cubical galena is found to be insensitive.

In this specimen, however, an exploring cat's whisker with a

fine point located sensitive spots almost anywhere on the crystal surfaces, even in the middle of a large smooth crystal-face; and on breaking open a crystal further numerous and excellent spots became available.

Tested in broadcast reception, this crystal showed a sensitiveness, quantitatively measured and observed aurally, on a par with the average good galena of the finely crystalline artificial type. Excellent crystal reception was obtained at 35 miles from 2LO on a poor aerial.

"Klybro" L.F. Transformer

Messrs. Klein Bros., Ltd., have submitted for test a sample of their "Klybro" L.F. intervalve transformer.

This is a large, handsome instrument, with high finish. There is a large, vertical coil, and the iron core is also of generous dimensions, whilst no bolts pass through the laminations. The four terminals are of convenient size, and very accessible on an ebonite panel which is mounted on the top of the instrument, the connections being clearly marked. Tested on high D.C. voltage, the insulation resistance, both between windings

and from windings to the frame, was excellent. The resistance of the secondary was rather unusually low, being only just over 2000 ohms. The makers did not state the nominal ratio of the windings. The resistance ratio was about 2 to 1.

On practical trial, in direct comparison with several other types of medium price and with our standard, both by aural observation of broadcasting and in quantitative measurement on a test signal, of uniform strength, the performance of this fine looking instrument was disappointing. The tone was dull and lifeless, and the actual build-up of signals, using the most suitable valves, H.T. value and grid bias, etc., fell short of even a mediocre specimen. Changing round connections effected no improvement. On testing the impedance of the primary and of the secondary windings separately, that of the primary was noticeably less than usual in standard instruments.

Taken together with the comparatively low D.C. resistance, it would appear as if the indifferent performance was due to lack of sufficient wire, as there were no signs of any particular fault.

**RADIO STOCKS (B. HAINE),
RADIO HOUSE, NEWMAN STREET, OXFORD ST., LONDON, W.1.
PHONE: MUSEUM 3205.**

EVERYTHING WIRELESS AT LOWEST PRICES.

All Goods on 24 Hours' Approval.

Send Ample Postage;

SEND FOR FREE LIST.

Surplus Refunded.

Accumulators. Best British, 4 Vt. 40 Amp. 17/6, 4 Vt. 60 Amp. 21/0, 4 Vt. 80 Amp. 27/6, 6 Vt. 40 Amp. 25/0, 6 Vt. 60 Amp. 30/0, 6 Vt. 80 Amp. 37/6, 6 Vt. 100 Amp. 45/0.

Coils. Basket, waxless, duplex set Nos. 25, 35, 50, 75 and 100, 2/0; for Chelmsford station, No. 150 1/3, No. 200 1/6. Ditto (extra large air spacings), Nos. 25, 35, 50, 75 and 100, 3/0.

Coil Holders. Radstock quality, solid ebonite, long handles or knobs, two way 2/3, 3/0, 4/0 and 5/0; ditto with Vernier fine adjustment 6/0, 8/6, 10/6. Three way, 3/6, 4/9, 6/9 and 8/6; ditto Vernier, 7/6, 9/6, 12/0. Basket Coil Holders, best, 1/0 and 1/3.

Ebonite Coil Plugs. 6d. each; curved, 1/0 each.
Condensers. (Copper and Mica.) Fixed; to .001 9d., to .005 1/0, to .01 1/9, to .1 3/0. Edison Bell Fixed Condensers, to .001 1/3, .002 upwards 2/0; Dubilier to .001 2/6, .002 upwards 3/0.

Crystal Detectors. Adjustable Enclosed, glass covered, 1/0, 1/6, 1/9, 2/6 and 3/0. Radstock Special Detector, micrometer movements, 3/0. All detectors stocked; Edison twin 5/0, etc.
Crystal Sets from 5/6 to 30/0.

Ebonite. Cut to size 3/6 per lb. Scrap Ebonite 2/0 lb.

Frame Aerials. Well made, fold up, in carrying case 21/0.

First-class Variable Condensers. Best British Make. Accurate Spacing. Perfect Finish.

	Ordinary.		Square Law.		With 3 Plate Vernier.
	s. d.	..	s. d.	..	
.001	7	3	..	9	6
.00075	6	6
.0005	5	4	..	8	9
.0003	5	1	..	7	6
.0002	4	5	..	6	6
.00005	3	1

Postage 6d. one condenser. 3d. each additional.

Mansbridge Condensers.

Special offer: "Octopus" brand, best quality obtainable; accurate, permanent, noiseless; tested at 350 volts direct current for insulation: there are none better: the result of 30 years' experience in condenser building; accuracy is guaranteed within 10 per cent.

.01, 2/0; .05, 2/6; .25, 3/0; .5, 3/4; 1mf., 3/6; 2mf., 3/10.

Sizes: 2 in. x 1 1/2 in. x 1/2 in.; 2 in. x 1 1/2 in. x 1/4 in.; 2 in. x 1 1/2 in. x 1/8 in.; 2 in. x 1 1/2 in. x 1/16 in.

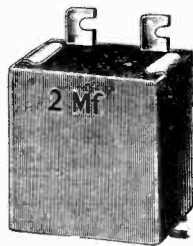

THE QUALITY OF OUR COMPONENTS IS GUARANTEED, AND OUR PRICES ARE THE BEST OBTAINABLE.

Filament Resistances. 1/6, 2/0 and 2/6 with engraved dial. "Microstat" for D.E. 2/6 each. "Radstock" 30 ohm 2/9, Igranic 4/6, Ormond 2/0. All makes in stock.

Headphones. "Brandes" 25/0. N. & K. pattern 12/9. "Continental" 12/11. Dr. Nesper's adjustable 12/6. Radstock lightweight 9/6. Jack and Plug, 3/0 the pair.

Leading-in Tubes, 12 in. 9d. each, 9 in. 8d., 6 in. 7d., "Simplex" flat lead-in 1/6.

Loud-Speakers. All makes stocked: Special Radio Classic, 20/0.

Sets (Valve). Splendid Selection, open or closed cabinets. From 3js. to £30.

Switch Arms: first quality 9d., Nickel 1/0, second quality 6d.

Switches. S.P.S.T., 1/0, S.P.D.T., 1/6, D.P.S.T., 1/9, D.P.D.T., 2/0. Panel mounting, S.P.D.T., 1/0, D.P.D.T., 1/6.

Transformers. L.F. "Powquip" 14/6, "Bucks" 12/6, "Radstock" 10/6, Royal 29/0—Best of all. All makes stocked.

Transformers. H.F. "Energo." Nos. 1, 3/6; 2, 3/9; 3, 4/3; 4, 4/6; 5, 4/9; 6, 5/0.

Terminals. Nickel 2d., Large W.O. & Telephone type 11d. each, Nickel 2d., Small Pillar & W.O. 1d., Nickel 2d., Spade 2 a 1d., Screwed Spade 1 1/2d., Screwed Pins 2d.

Variometers. Double wound 150/550, 2/0, on ebonite 3/0, finest make "Radstock" moulded ebonite ball rotor, close coupling, 6/0. Edison Bell 10/0, Igranic 12/6. All makes stocked.

Valve Holders. Best turned ebonite, with nuts 10d. Radstock Anti-Capacity, legless, 1/0 each, Murrays 1/3; highly recommended.

Valve Legs. With nut and washer plain 11d. each, 9d. doz., nickel 1 1/2d., 1/3 doz., flanged 1 1/2d. each, 1/3 doz., nickel 2d. each, 1/9 doz.

Valves. Tested before dispatch and sent at purchaser's risk. Dutch "R" 5/6, French R 6/6. All makes stocked.



Solder all connections. Where you can't - Use CLIX!

CLIX PROVIDES AN IDEAL POINT FOR SOLDERING

Perfect contact—instantaneously—everywhere.

The tapered design of CLIX plug-socket ensures full surface contact in every one of its countless applications.

That's why CLIX supersedes all forms of Plugs, Terminals, and Switches, and has standardised the wiring of all radio circuits.

Retail Prices

CLIX with Lock-rut, 3d.

CLIX Insulators (6 colours) 1d. each.

CLIX Bushes (6 colours) 1d. per pair.



The **Electro-Link** with **159 Uses**

Obtainable from all Wireless Dealers or direct from the Patentees and Manufacturers:



Radio Engineers and Contractors,
84 VICTORIA STREET, LONDON, S.W.1.

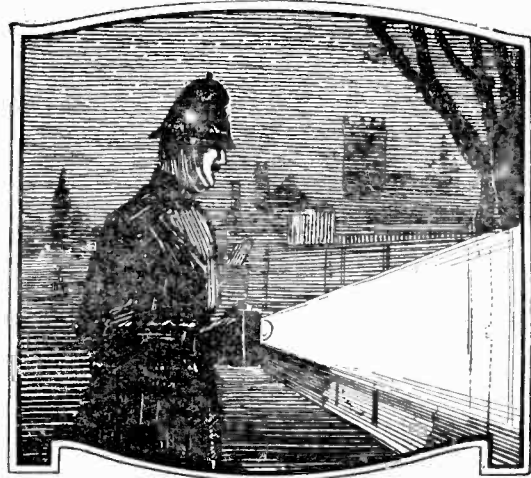

Dark Nights

POETS have sung the praise of moonlight nights, but it is left to the burglar to sing the praise of dark ones. The average man is not a mystic—he likes to see what he is doing. It is a cynical axiom that he also likes to see what his neighbours are doing as well.

There is not much peace of possession in a Wade Lathe if one's neighbour sees it arriving, so when you order yours get it delivered on a foggy night.

Below is illustrated the Wade No. 2 Lathe It is Back Geared, Self-Acting and Screw-Cutting. It has 13 change wheels, which cut all threads, right or left hand, from 6 to 60 T.P.I., including metric pitches. It takes work up to 4-in. diameter and 12-in. in length, and the way in which it does its work of turning, boring, facing and drilling, is a source of wonder to its many users.

If you would like one of our fully descriptive catalogues post free, drop us a card to-day. Write to Dept. E.

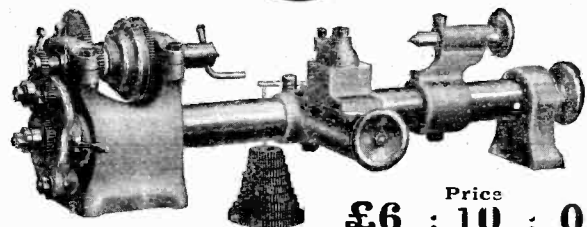

Price
£6 : 10 : 0

C.A.V. Small Tools, Ltd., 181, Queen Victoria Street, E.C.4.

E.F.S. 20

In replying to advertisers, use COUPON on last page

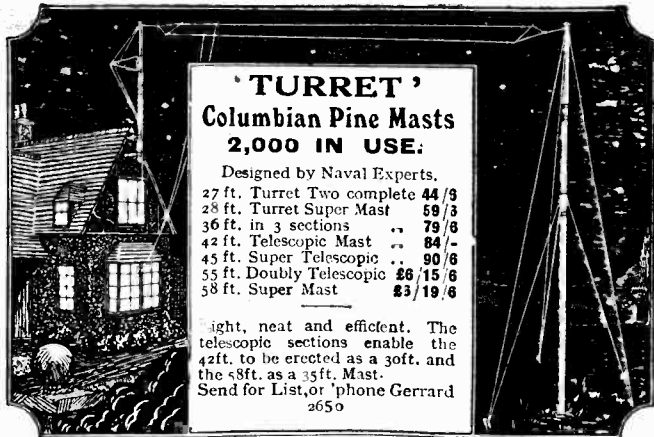

'TURRET'
Columbian Pine Masts
2,000 IN USE:

Designed by Naval Experts.

27 ft. Turret Two complete	44/9
28 ft. Turret Super Mast	59/3
36 ft. in 3 sections	79/8
42 ft. Telescopic Mast	84/-
45 ft. Super Telescopic	90/8
55 ft. Doubly Telescopic	26/15/6
58 ft. Super Mast	23/19/6

Light, neat and efficient. The telescopic sections enable the 42ft. to be erected as a 30ft. and the 58ft. as a 35ft. Mast.
Send for List, or 'phone Gerrard 2650

SIMPSON & BLYTHE, 8-9, Sherwood St., Piccadilly, W.

BUILD SILENCE into your RECEIVERS

Variable grid leaks can be responsible for much bad reception. Mysterious valve noises do emanate from the grid leak. And when followed by one or two stages of L.F. amplification these noises are both annoying and tiresome. After considerable experiment we discovered that bad or chance contact between the plunger and the collar is one origin of noise. Hence the **WATMEL** is now fitted with a refinement—a small but very effective spring which, anchored to the collar, presses firmly upon the plunger. Electrical contact is therefore always good—and noise due to a faulty connection is eradicated permanently in the **WATMEL**—a consideration which definitely inclines your choice for a grid leak to the



All goods of our manufacture bear this mark. It is your only guarantee.

This same refinement is also standard to the



Anode Resistances.

IMPORTANT NOTICE to intending purchasers

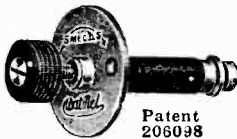

Patent
206098

5 to .5 Megohms ... 2/6
50,000 to 100,000 Ohms. 3/6
Other Resistances to suit any circuit.

Send P.C. for Descriptive Folder. SEE THE TRADE MARK.



ON EVERY GRID LEAK. BEWARE OF IMITATIONS.

The Watmel Wireless Co. wish to notify the trade and public that their Variable Grid Leak Patent Application No. 206098 was contested in the Comptroller's Court, and on Appeal; in both instances the Patent Grant was upheld and costs awarded.

It is the aim of this Company to protect traders', customers', and also its own interests by securing Patent protection for the novelties in its specialities, as it is these novelties, invented by experts and exhaustively tested, which are the Hall Mark of all Watmel Products.

THE WATMEL WIRELESS CO.
332a, Goswell Road, London, E.C.1.

Telephone

CLERKENWELL 7990.



MADE IN ONE PIECE; NO WAX.

Patentees and Manufacturers:
THE PARAGON RUBBER MFG. CO., LTD.

Guaranteed uniform accuracy under all conditions and at all temperatures.

PROOF

Test Report by

A. D. COWPER, M.Sc., Staff Editor,
"Modern Wireless."

ACCURACY

"On test, the capacities came out quite close enough to the nominal for ordinary radio purposes, the .001 μ F nominal samples being about .00103 and .00091 respectively, and the .0003 μ F nominal being actually around .00033 and .00026 respectively. There was observed but a negligible greater high-frequency loss in this type than in a standard air-dielectric condenser."

PERMANENCY

"As this one-piece casing offers apparently considerable advantages as to permanency and independence of damp, high temperature, etc., an exceedingly strenuous test was applied to one of the samples, which was actually placed in water nearly at the boiling point for the better part of an hour. After this heroic treatment, the condenser showed a capacity which did not differ materially from that shown before, and it was still possible to get a valve to oscillate readily with this as the main tuning-capacity across the grid-tuning-inductance. Evidently there need be no fears as to possible deterioration in stock of these 'Paragon-Curtis' fixed condensers."

And THEREFORE

As Used in the
"MODERN WIRELESS" MASTERPIECE

The 7-Valve T.A.T. Receiver
By JOHN SCOTT-TAGGART

The above test reports have never before been equalled and are the exclusive features of the Paragon-Curtis Condensers.

ASSURE BEST RESULTS BY USING
THE BEST COMPONENTS

.0003 to .006	2/6 each
Grid Condenser with clips	2/9 "
Grid Leak	1/6 "

PETER CURTIS LTD.
75 · CAMDEN ROAD · N.W. 1.
Telegrams: "PARACURTEX" — 'Phone: NORTH 3112.
IN CONJUNCTION WITH
The PARAGON RUBBER MFG. CO. LTD.

Lissen Variable Condenser

Messrs. Lissen, Ltd., have sent for our test samples of their one-hole-fixing type of variable condenser, together with a number of their "Lissenagon" tuning-coils, for trial in combination with this condenser.

The condenser is enclosed in a brass case, 3½ in. diameter by ½ in. thick. The case itself is earthed and carries one small terminal on one side. The other terminal is mounted on an insulating bush of small diameter at the opposite side. The customary one-hole fixing is provided, and a black circular scale, with knob and pointer, is supplied for mounting on the panel.

The knob makes almost two entire revolutions, so that the scale is divided from 0 to 12 divisions, and then repeats, giving in all 25 divisions. Positive stops operate at each end of its travel.

On measurement, the capacity range was from the appreciable

involved, it is difficult to see what value the first whole revolution will have in most circuits. The minimum is too high for efficient use as a fine adjustment condenser in parallel with a larger one in most cases.

Used in conjunction with the "Lissenagon" coils, the wavelength ranges were from 160 to 568 metres with the No. 35, 170 to 600 metres with the No. 40, 210 to 800 metres with the No. 50, 240 to 940 metres with the No. 60, and 325 to 1,250 metres with the No. 75. It will be noticed that the available range on any one coil is large, when used thus with only the casual capacities of the valve panel used (some 25µF), suggesting a low self-capacity in the coils as well as a large capacity range in the condenser. The coils have evidently been carefully designed to eliminate unnecessary H.F. resistance, by the use of a reasonably large gauge of wire in each case—being markedly superior to some other types in this respect,

covers approximately the main B.B.C. station wavelengths.

The reaction demands with this condenser as main tuning-capacity were just noticeably greater than with a standard type of air or mica condenser. This was more than compensated for by the low resistance of the coils. Generally a size smaller reaction coil could be used than is customary, and this coupled at such a distance that the usual annoying change of wavelength with reaction coupling was greatly diminished. There was no difficulty in going the rounds of the main B.B.C. stations (except Aberdeen, which was jammed by Morse as usual), some of the relay stations, and half-a-dozen Continental stations in daylight on an indifferent country test aerial, with the No. 35 coil and a single D.E. valve.

We can strongly recommend these excellent low-resistance inductances for use in combination with this condenser over the limited useful range of the latter, or in general with the conventional type of air condenser.

The measured crystal signal strength (at 35 miles from 2LO) with the No. 35 coil and Lissen condenser was at least as good as with any other commercial types of plug-in coils tried, and approached very close to our standard at this distance and on the same aerial.

New Pattern Watmel Grid-Leak

Messrs. Watmel have handed us for our inspection and test samples of a new pattern of their well-known variable grid-leak in which the possibility of a certain irregularity of action when the instrument has been in use for some time and is showing, perhaps, some looseness in the spindle through wear, is effectively eliminated by the provision of a spring-contact to the central spindle at the knob end of the instrument. Thus, in this latest pattern, a spring brush bears down on the spindle through a slot cut in the end bush, and makes at all times effective and silent electrical contact with the screw spindle, even when, by long use, the latter has perhaps become a little loose in its bush.

On test, the samples showed a steady variation in resistance value from about 0.6 to 4 and 0.7 to 4 megohms respectively, the values being fairly reproducible, and they were silent in operation. This small addition should prove a valuable feature in these grid-leaks.

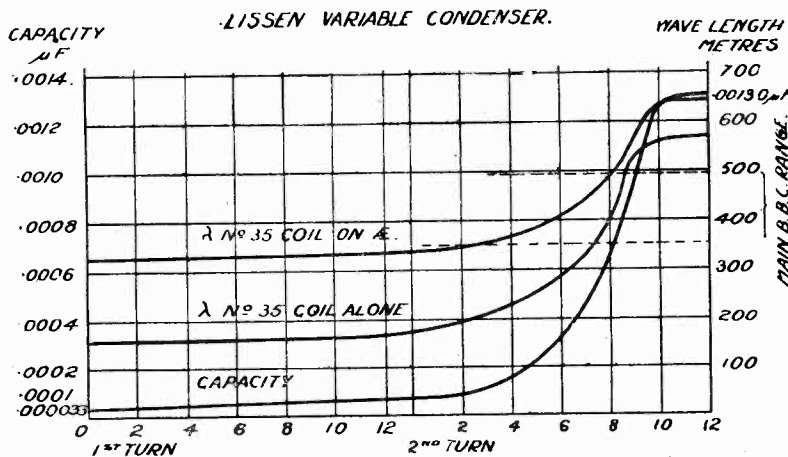

The above curves show how the capacity and also wavelength with various coils vary with the Lissen condenser.

minimum of 33 micro-microfarads (-000033µF) to the high maximum figure of .0013µF. The minimum capacity is, however, quite a small percentage of the maximum. The capacity varied in a curiously irregular way with the setting, as shown in the accompanying figure, determined by the writer on the sample submitted for test. The whole of the first turn adds very little appreciably to the existing minimum capacity. Then the change is fairly rapid for four or five divisions (one-third of a revolution), and finally becomes again very slow for three divisions. With the quite appreciable minimum capacity inevitable in so totally enclosed a condenser, and small clearances

giving as a result noticeable ease of oscillation and sharp tuning. The inductance value appeared to be somewhat less than that customary for the particular number of coil.

The actual wavelength obtained with the No. 35 and the Lissen variable condenser was plotted, firstly, with valve and casual capacities alone; secondly, with the 70 ft. low single wire test aerial in parallel with the rest. The figure shows, as expected, that the effective portion of the scale was between divisions Nos. 4 and 9 of the second turn, a fairly flat characteristic being obtained over this region, which in the case of the coil connected to the aerial

CLIMAX

RADIO

METAL FOR ME

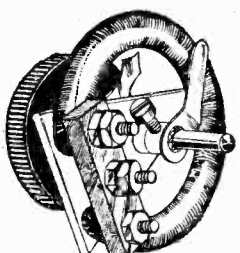

I've learnt the sound wisdom of metal.

It's sound, unbreakable and unburnable—that's why I use Climax Rheostats and Potentiometers.

They're metal-cooled, too! Just listen.

The resistance element is a wire spiral wound on a solid metal rod and insulated by vitreous enamel applied at a temperature of 1,300 Fahrenheit and capable of standing an electric pressure of 2,000 volts. The cooling far exceeds that obtained by any other method, making a single standard pattern equally suitable for one, two or three valves. Neither the insulating material nor the resistance element can be burnt, broken or displaced. The wire resistance element gives a perfectly smooth adjustment. It is solid, and therefore cannot be mechanically damaged. It is in intimate contact with a cooling mass of metal, and therefore cannot be burnt out.

No noise can be set up in the receiving set. These are marked points of superiority over all types of rheostat, including those employing granular or fibrous material.

TEN GOOD FEATURES.

- (1) Solid, rigid coil.
- (2) Perfect cooling.
- (3) Insulation stands high temperatures and voltages.
- (4) Unbreakable Bakelite terminal bar.
- (5) Large and well-spaced terminals.
- (6) Steel grub screw fixing for contact brush.
- (7) No lock nuts to work loose.
- (8) Riveted brush, with perfect brush contact.
- (9) Takes any panel up to 3/4 in. thick.
- (10) Bakelite knob with blind brush. Will not work loose.

Price:—Climax Rheostats, 6 ohm pattern, 3/6 each. Postage 3d.
 Climax Rheostats, 30 ohm pattern, 4/6 each. Postage 3d.
 Climax Potentiometer, 300 ohm pattern, 6/- each. Postage 3d.

CLIMAX PATENTS, Ltd.,
 182, Church Street, London, W.8.
 Telephone: Park 2003.

Readers' Results with Radio Press Sets.

To the Editor of MODERN WIRELESS.

A Two-Valve Double Reaction Receiver

SIR,—Many congratulations to Mr. H. K. Simpson on designing such an excellent receiver as the "Two-Valve Double Reaction Receiver" (M.W., Vol. 3, No. 4).

I had taken my four-valve receiver to pieces to wire it up again with new wire when I decided to wire up the above two-valve set in order to listen in.

When I switched on to test the

would advise them to use this one as it is Ar for both.—Yours truly, B.G. Co. Antrim.

P.S.—I decided to sit up and try for America and was successful in receiving the following *loud and clear*: WJZ, WGY, WBZ, and WNAC.

A Two-Valve Cabinet Receiver.

SIR,—I have just built for a friend the two-valve receiver described by Mr. Rattee in the June number of MODERN WIRELESS, and the results with it are so surprisingly good that I feel it my duty to report them.

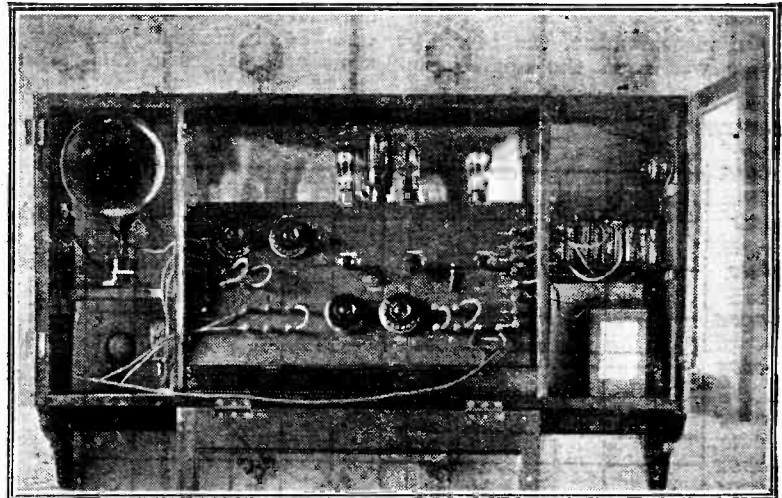

A handsome 3-valve dual receiver as constructed by Mr. Aitchison.

set I was astonished to hear a foreign voice; this I found was Berlin Telefunken on 290 metres. I was so much surprised with this reception that I decided to try for other stations. The following are those received. Belfast 435 metres, Glasgow, Newcastle and all B.B.C. stations, including three relay. L'Ecole Supérieure, Radio Belgique, Radio-Paris, Breslau, Madrid, Gothenburg, Leipzig, Vienna, Frankfurt, Lyons, Hamburg, Lausanne, Stuttgart, and Vox Haus.

I think this is a good record for one night. I can tune out Belfast at about eleven miles and receive any other stations, but of course I can hear Belfast faintly when receiving Glasgow.

To anyone wanting a set with both great volume and purity I

All the B.B.C. stations and seven of the relay stations were easily received. Three French stations followed, with Brussels, Madrid, an unidentified Continental station which works on nearly the Aberdeen wavelength, and, of course, Chelmsford. Then followed, to my surprise, four American stations, two of which I get any night, WBZ and WGY, the former as loud and clear as many of the B.B.C. stations. Last night I tried a coil of wire lying in a corner of the room as an aerial, and got three of the B.B.C. stations. What more could anyone want?

I feel bound to let you know of these results, and trust that many more will be encouraged to make this set.—Yours truly,

(Rev.) R. D. E. STEVENSON.
 Colmonell, S. Ayrshire.

(Continued from page 895.)

is not done the difference in voltage between the two L.T. voltages is applied in an indirect manner to the filaments, and serves to unnecessarily run the battery down. When the same L.T. is used on all valves this does not occur and only the switch S need be switched off.

The filament circuit being found correct, plug-in transformers for the wavelength range required should be inserted in the transformer sockets, and a suitable value of H.T. applied to all the valves. To do this as a preliminary arrangement all the H.T. plus terminals may be connected together and the grid bias terminals shorted.

H.F. Transformers.

A word as to transformers is required here, since, unfortunately, different makes vary in connections. I have used McMichael type and also for Burne-Jones and Bowyer-Lowe make, which are similarly connected. With other makes it may be necessary to try the effect of reversing either the neutrodyne or anode windings, whichever is most convenient. The types having separate slots for each winding are to be preferred.

If the H.T. connections appear to be correct, insert a coil (one suitable to cover the range required without an aerial, e.g., a 50 or 75 Gambrell C, or equivalent coil for the broadcast range) into the fixed socket. Short sockets 4 and 5, joined A_1 to E, and also short sockets 6 and 7. Now leaving the aerial condenser set about 20 deg., vary the anode condensers simultaneously, tapping at the same time the aerial terminal. With the phones inserted in the jack, loud "plonks" should be heard over a band of condenser degrees. Now try the effect of screwing in the neutrodyne condensers, tapping the aerial terminal as before, and occasionally varying the anode condensers. If correctly connected a little practice should finally give an adjustment of the neutrodyne condensers, which gives

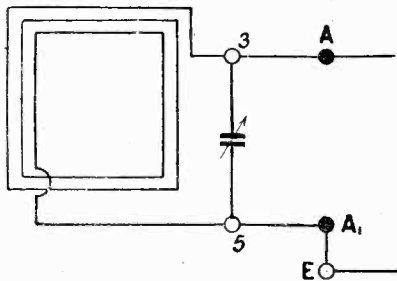

Fig. 8.—Simple frame aerial connections.

complete stability with any combination of anode and aerial condenser positions. If this is not obtained the windings to anode or neutrodyne coils should be reversed and the process repeated. Unfortunately there is no "rule of thumb" method of neutroding as with a single H.F. valve, but a little practice should easily give the correct adjustment required.

Preliminary Test Report

The set was tested for sensitivity at about 12 miles S.E. of 2LO on a Portable Utilities' frame aerial of hexagonal shape and about 4 ft.

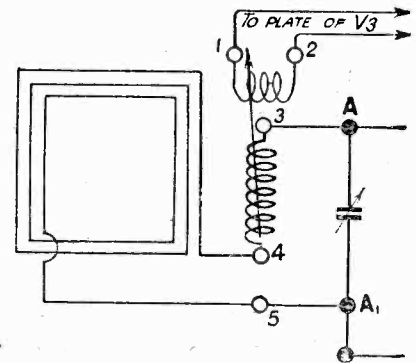
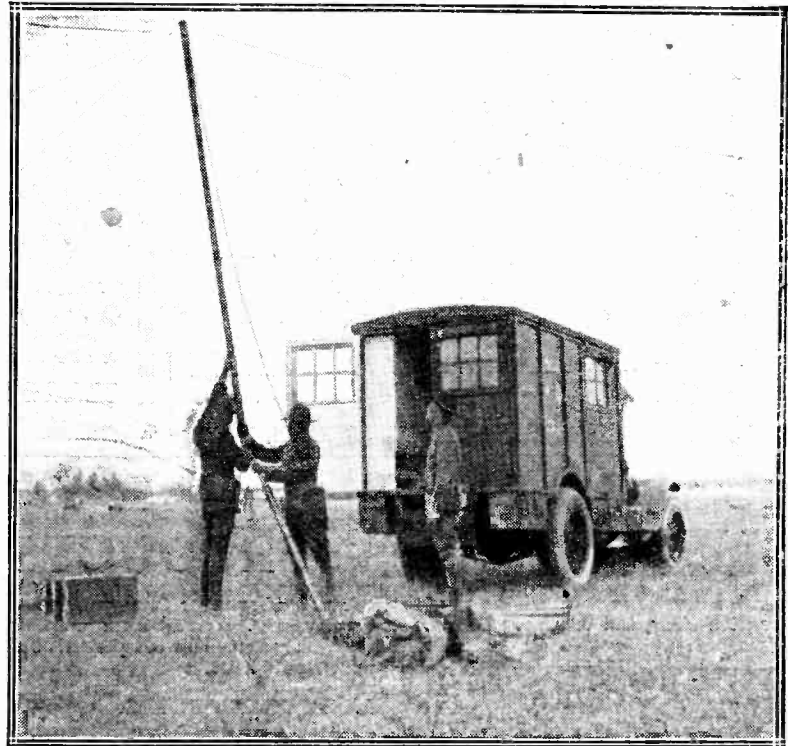

Fig. 9.—How to use reaction with the frame aerial.



Erecting the aerial of a United States Army Field Station.

diagonally. General purpose valves and 60 volts H.T. were used. The ordinary 300- to 600-metre type of transformers were not found to go low enough to give really definite tuning on London, but on substituting specially wound ones of Magnum make London was received at good loud-speaker strength, and later Madrid on phones without the L.F. valve. Several makers are now putting on the market transformers wound with a lower minimum suitable for this type of set, which should be available by the time this appears in print. A full test report on an outside aerial and further operating details will be given next month.

Note on Wiring Diagrams

In all wiring diagrams the method of showing loops where wires pass over each other without joining has not been used, as this does not give a true impression of how the leads are taken. With the method now used, the wires are taken as in the set and joins are shown by small black squares; where there is no square, wires are not joined.

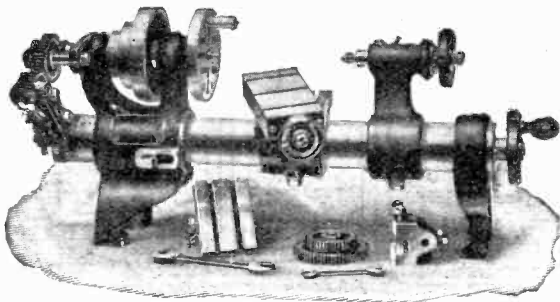

The DRUMMOND 4-in. Multi-purpose Lathe.

Make your own parts!

—half the fun in Wireless is gone if you buy everything complete

Winding coils, turning up formers, plugs, knobs—a hundred and one jobs, drilling, slotting, boring, screw-cutting—all may be done well and cheaply on the Drummond. A contact stud—or a bush for your car—make it yourself, and pay for the lathe with the money you save.

DRUMMOND Bros. Ltd., REID HILL, GUILDFORD.

—Post this Coupon—

Please send me, post free, lists of your small lathes, with details of deferred payment system.

Name
 Address

(Send in unsealed envelope for 1/4d.)

B.B.C.

WIRELESS DRY BATTERIES

For **B.B.C.** Sets

No. 1 W.

Standard Pocket Lamp Size—4½ volt with patent spiral wire terminals and plug sockets to take Wander Plugs.

Note:—1 doz. = 54 volts.

Used units replaced easily.

Connect as illustrated.

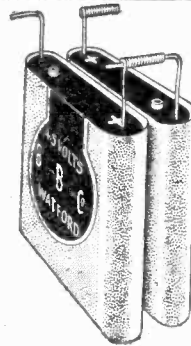

To connect in Series insert straight Terminal in Spiral of next battery. Bend spiral and thus ensure permanent electrical connection without soldering.

BRITISH MADE.

Patent No. 202760.

PRICE CARRIAGE PAID, 7/- PER DOZEN, WITH PLUG.

Standard Sizes:

No. 2 W. Slab. 16½ volts, 3-volt tappings.	Size approx. 9 x 1 x 3 ins.	Price 3/- each
No. 4 W. Slab. 36 volts, 3-volt tappings.	Size approx. 10 x 1½ x 3 ins.	6/6 "
No. 5 W. Block. 60 volts, 3-volt tappings.	Size approx. 9½ x 3½ x 3½ ins.	12/- "

Prices include Wander Plug. Carriage Paid.

Manufactured by—

Telephone: Watford 617.

The BRITISH BATTERY CO. LTD.
 CLARENDON RD., WATFORD, HERTS.

YOU WILL HAVE A HAPPY NEW YEAR WITH "SUPRATONE" PRODUCTS!

This 2-valve amplifier will enable you to work a loud-speaker from your present detector with clear, full volume. The circuit employed gives maximum amplification, only first-class components being used throughout.

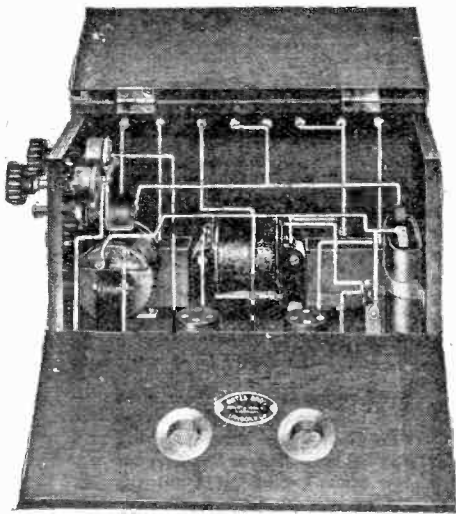

LEADING FEATURES.

- 2 SUPRA transformers.
- 2 MICROSTATS. 83-5-Y pull-push switch for filament circuit.
- 2 MANSBRIDGE Condensers. Modulating resistance. Negative grid bias.

Supplied in beautiful mahogany cabinet with hinged top and side. A high-grade instrument in every way, fully conforming to our value-for-money policy.

£4

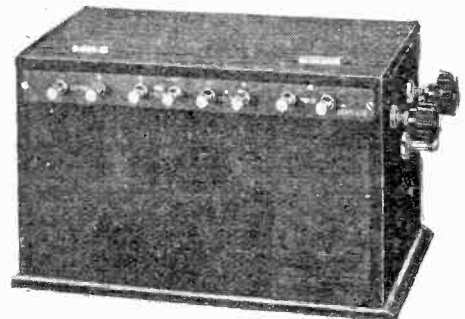

4000-ohm HEADPHONES.

Compare them with others and you will realise our claim to "lifelike reproduction" is not exaggerated. They weigh only 8 ozs. and have adjustable DURALUMIC headbands and earpieces. Price includes best quality cords.



Price **£1**

Send to-day for our interesting 1924/5 catalogue—full of bargains.

WATKES
 BROS., LTD.,

12, 13, 14, Great Queen St., Kingsway, W.C.2.
 Phone: Gerrard 575 & 576. Grams: Zylwaleseng, Westeejit.
 Works: LONDON, BIRMINGHAM & WESTCLIFF.

SELECTIVITY

Statement and Proof
Q.E.D.

The immediate result
of

LOW SELF-CAPACITY

NOTE THE EXTRAORDINARY
LOW SELF-CAPACITY of
"Tangent" Tuning Coils

(The Unshrouded Coil)
and you will realise their extreme
SELECTIVITY and EFFICIENCY

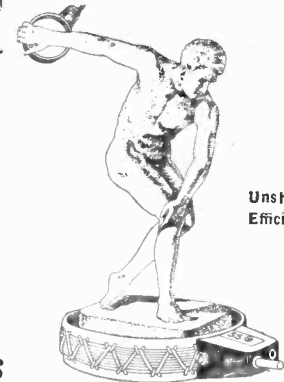

Unshrouded
Efficiency.

NATIONAL PHYSICAL LABORATORY REPORT.

Coil No.	Self-Capacity in Micro-Microlarads	Prices.
25	8	4/3
35	9	4/3
50	25	4/3
75	31	4/3
100	22	5/-
150	16	6/-
200	22	7/-
250	22	7/8

Ask your dealer for Tangent Coils — obtain SELECTIVITY and add 30% volume to your present reception — so cut out your local station.

COMPLETE SETS.

4 Concert Coils
(Nos. 25 to 75, 15/- the set,

11 Concert Coils
(Nos. 25 to 500) 67/- the set.

London: 25, Victoria Street, S.W.1.
Newcastle/Tyne: "Tangent House,"
Blackett Street.

GENT & CO. LTD. Est. 1872.

Manufacturing Electrical Engineers,

Faraday Works,
LEICESTER



"UTILITY"

VARIABLE

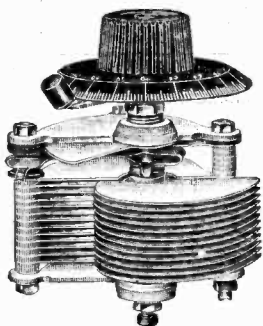

W.M. 124

PRICES
SQUARE LAW
OR
ORDINARY.

Model	Value	Price	Each
WM. 123	.001	12/6	
WM. 144	.00075	11/9	
WM. 124	.0005	10/6	
WM. 125	.0003	8/9	
WM. 145	.0002	7/9	
WM. 146	.0001	7/6	

Vernier 2/6 extra.

FITTED WITH "RADION" DIALS

Manufactured by

WILKINS & WRIGHT, LTD.,
Utility Works, Kenyon Street,
BIRMINGHAM.

CONDENSERS

*That Straight line
Protects you*

When your lightning-arrester device puts the aerial lead and the earth in a *straight line*, your aerial is a definite protection to your house.

A house with an aerial and a Pressland Safety Lead-in, is safer than a house without an aerial.

It is futile just to connect aerial and earth terminals on your set, or to adopt any device that does not connect aerial to earth *outside* the house. Lightning will not follow angles; it takes a straight line.

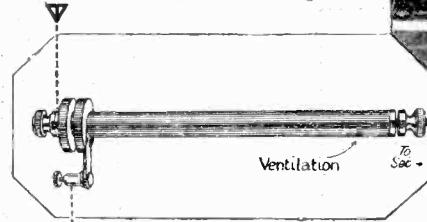
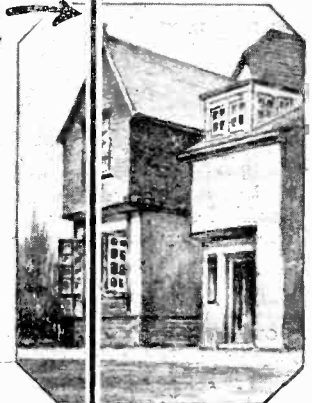

The Pressland Safety Lead-in has a self-contained discharge-gap, and provides for an external earth-wire. It is scientifically shaped to form a petticoat insulator—free from surface leakage.

The Pressland Safety Lead-in

From your Wireless Dealer. Sizes: 6-in., 3/-; 9-in., 3/3; 12-in., 3/6.

Manufactured by
PRESSLAND ELECTRIC SUPPLIES, LTD.,
Hampton-on-Thames.
Phone: Molesey 22.

Inquiries are invited from all sections of the Trade.

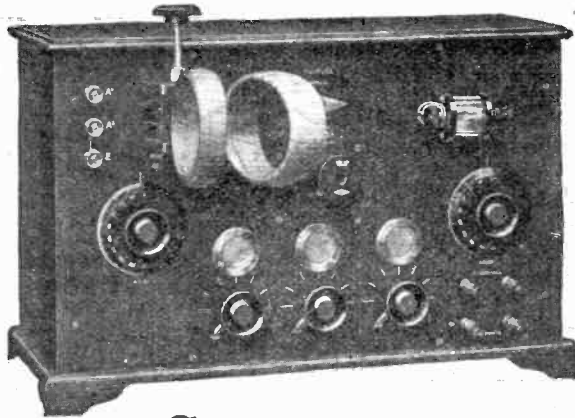

Left :
Puriflex
Receiver.

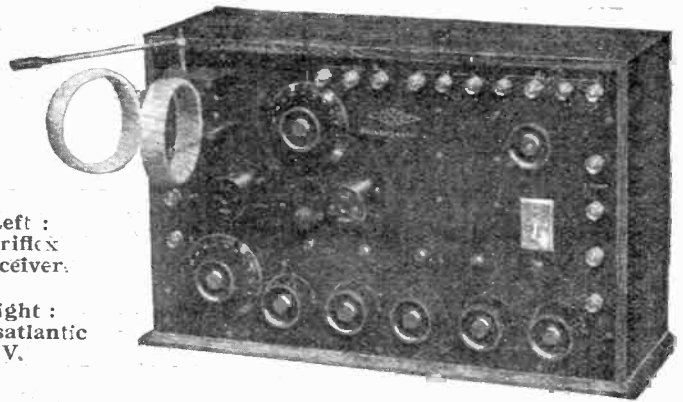

Right :
Transatlantic
V.

Save pounds by building any guaranteed Pilot Set yourself

THE Pilot System has solved the problem of the home built Set for thousands of Home Constructors. It has provided the only satisfactory method of getting an excellent Receiver which possesses the appearance of a ready-built Set costing five times the price at the cost of only the components. And anyone can build one of these Pilot Sets without previous experience. All parts are so carefully made that they fit together like a charm. The only tools required are screw-driver and a pair of pliers. Even soldering can be dispensed with if necessary.

Failure quite impossible.

No one has ever been known to fail. Even boys of fourteen have built up some of these well-known multi-valve Sets and have got perfect results. With each complete set of parts is supplied a blue print containing all wiring instructions. Every step is carefully shown and failure is quite impossible. Even if you should go wrong the Set can be returned to our Service Dept., to be put into working order for a nominal charge. Remember any set of parts includes every

possible item (except coils and valves) and is complete down to the last screw. Owing to our huge manufacturing resources we are able to offer you complete Sets of parts for any "Modern Wireless" Receiver at several pounds less than you could purchase them yourself locally. And in addition you are sure of getting parts matched to work together under our guarantee. If on the other hand you already possess some parts we will supply

you with an engraved panel and cabinet or any component you need.

Send to-day.

Send at once for our large Pilot Folder showing illustrations of all principal "Modern Wireless" Sets and their descriptions. A postcard brings it by return free. Comparison of prices will prove that you can save pounds by getting all your parts from one source of supply.

Choose your Pilot Set from this Chart :

Name of Receiver.	Price of Panel drilled and engraved.	Kit of Components	Oak Cabinet with baseboard.	Finished Instrument with coils, Royalties paid.
All Concert-de-luxe	13 6	£4 17 6	17 0	£13 10 0
S.T. 100	7 0	£4 16 0	£1 10 0	£ 9 12 6
Puriflex	12 6	£4 5 0	17 0	£11 11 0
All-Britain	13 0	£4 9 0	17 0	£14 14 0
4-Valve Family	19 6	£5 15 6	17 0	£17 10 0
Transatlantic V.	13 6	£5 4 6	17 0	£18 18 0
Anglo-American 6	£1 8 6	£9 5 0	£3 0 0	£30 0 0
	(Without engraving)	(Type B.)	(Mahogany 3/- extra.)	
Transatlantic 4	16 6	£6 15 0	£1 7 6	£20 0 0
	(including terminal board)	(Type A.)	(Mahogany)	
3-Valve Neutrodyne (Valve panel)	10 6	£4 10 2	£1 13 6	On application.
3-Valve Neutrodyne (Tuner Panel)	10 0	£4 2 3	to take both panels.	On application.
T.A.T. 4-Valve Receiver	£1 5 0	£5 15 0	£1 0 0	On application.
		(Type A.)	(Mahogany)	

† SPECIAL NOTE: Where all components and panel are purchased together a Marconi Royalty of 12s. 6d. per valve holder must be paid.

"Red Triangle" Panels

FOR your Ebonite Panel be sure you use Red Triangle Ebonite. Every sheet fully guaranteed free from surface leakage. Tested by Professor A. M. Lowe and certified by him to have passed the most stringent tests. All edges squarely cut and surface finished smooth matt. Sold in the following 12 stock sizes all 1/4 in. thick.

6 x 8 3/-	8 x 6 3/-	10 x 24	15/-
6 x 18 8/-	8 x 10 5/-	12 x 14	10 6
7 x 5 2/3	8 x 12 6/-	12 x 16	12/-
7 x 10 4/3	10 x 12 7 6	12 x 18	13 6

PRICES OF "MODERN WIRELESS" PANELS

All Concert de-Luxe	16 x 8	1/2 x 1/2	8 0
Transatlantic V.	22 x 11	1/2 x 1/2	15 0
All Britain	16 x 9	1/2 x 1/2	9 0
S.T. 100	12 1/2 x 9 1/2	1/2 x 1/2	7 0
Puriflex	14 x 10 1/2	1/2 x 1/2	9 2
Resistolex	12 x 8	1/2 x 1/2	6 0
Transatlantic IV.	16 x 8	1/2 x 1/2	8 0
Anglo-American	16 x 9	1/2 x 1/2	£1-0-0
Neutrodyne Tuner	12 x 10	1/2 x 1/2	7 6
Neutrodyne Receiver	12 x 10	1/2 x 1/2	7 6
3-Valve Dial	24 x 10	1/2 x 1/2	15 0
Harris Crystal Set	9 x 5 1/2	1/2 x 1/2	4 4

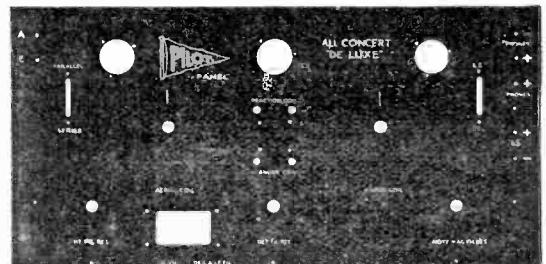

PETO-SCOTT CO. LTD.,

Registered Offices, Mail Order & Showroom,
77, City Road, London, E.C.1.

Branches : LONDON 62, High Holborn, W.C.1. PLYMOUTH—4, Bank of England Place.
LIVERPOOL—4, Manchester Street. CARDIFF—94, Queen Street.
WALTHAMSTOW—230, Wood Street.

P.S. 1920

Peto-Scott's Wireless Book.

Contains over 80 circuit diagrams and much wireless information. An excellent all-round simplified treatise on Wireless

1/3

1/5 post free.

SEND FOR CATALOGUE

48 pages of illustrated components. Best in London for high-grade apparatus. Other advertising literature sent free.

3d.

post free.

FALLON'S "DUANODE" (Regd.) CONDENSER

Designed to simplify the tuning of two stages of High-Frequency Amplification.

The "DUANODE" (Regd.) has been favourably mentioned by Mr. Percy Harris of "Modern Wireless" in a recent article on the subject.

Price 17'6

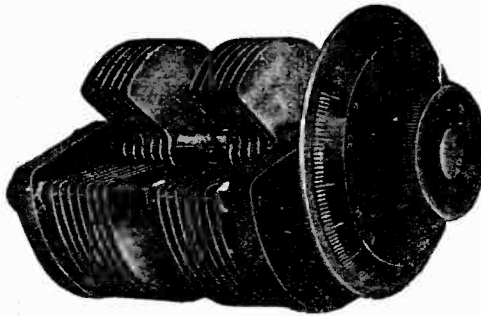

This Condenser consists of TWO matched Condensers, operated by one knob, thus by using matched COILS it is possible to tune BOTH Circuits perfectly with one operation only. If any difficulty is experienced in matching the coils they may be roughly matched, and a Vernier Condenser connected to parallel with the smaller. The two sets of Fixed Vanes are carefully insulated one from the other and the moving VANES connected electrically, the spindle can thus be connected to H.T. Positive. This Condenser can also be used for other purposes. The two halves (each of .0025 mfd.) can be used in series or parallel giving capacities of .00125, .0025 and .005.

"SQUARE LAW VANES"
Metal Ends if desired.

If your local dealer cannot supply you, we will.

Read what "AMATEUR WIRELESS" says about it, after severe test conducted by J. HARTLEY REYNOLDS.

Reprinted from "Amateur Wireless," July 5, 1924.

Everyone who has worked with two stages of tuned high-frequency knows what a difficult matter searching for weak signals can be. If a double-circuit tuner is in use without a tune-stand-by switch one has at least four condensers—the A.T.C., C.C.C. and the two anode-tuning condensers—to attend to, all of which should be moved simultaneously, though this is obviously an impossibility for the hands of a normal human being to accomplish. By fitting the tune-stand-by switch the secondary can be thrown out of action, thus reducing the number of condensers to three; but even this is one more than our hands will permit us to deal with simultaneously. If well-made and well-matched inductances of transformers are used for the couplings of the high-frequency valves it will be found that the condenser settings (provided, again, that these are well made and well matched) will be always almost exactly the same for all signals.

It is possible now to buy from any good maker pairs of inductances which are precisely similar in their characteristics, and manufacturers are also turning out high-frequency transformers in matched pairs. This being so, there is no reason why the

anodes of two high-frequency valves should not be tuned simultaneously with some device which enables the two condensers to be coupled. Various expedients have been brought out for the purpose, one of which, connecting the two condensers by gear wheels, works quite well; but the best of all is the double condenser, in which the turning of the knob actuates two separate sets of moving plates.

The Fallon "Duanode" condenser has, as the photograph shows, two sets of fixed plates each well insulated from the other.

The moving plates have a common spindle and the two sets are not insulated from one another. It is not necessary to insulate the upper tier of moving plate from the lower tier, for the very simple reason that both high-frequency valves have a common connection—to high-tension positive. One therefore wires up this condenser in the following way: The anode end of the inductance or of the primary of the high-frequency transformer of the first valve is taken to the upper set of fixed plates, the lower set being connected to the anode end of the coupling of the second valve. The moving plates are then connected to high-tension positive. Any over-

ment of the knob will thus tune both anodes simultaneously.

When the double condensers were first brought out I was a little sceptical about their efficiency, for it seemed that unless matching was perfectly carried out there would be a distinct loss in efficiency, since one anode or the other would usually be slightly detuned. For this reason I fought shy of them for some time, and always fitted two condensers to sets with a couple of high-frequency stages, making use of a wavemeter for searching purposes. After trying the Fallon "Duanode" I am quite converted to the double condenser, which renders searching even with a large set quite easy. When a tune-stand-by switch is fitted one simply throws it over to the stand-by position, thus using only the aerial tuning circuit; the whole process can be carried out with the left hand on the knob of the A.T.C. and the right on that of the double-anode condenser.

In the Fallon "Duanode" under test it was found that both halves were matched to perfection. When tried against two separate condensers it was found that there was not the slightest loss in signal strength, and it was possible to tune both plates sharply.

Wholesalers and Retailers should apply for Trade Terms to:

FALLON CONDENSER CO., LTD.,
WHITE RIBBON WORKS, BROAD LANE, TOTTENHAM, N.15.

Branches: 143, Farringdon Road, E.C.1; 3, King's Street West, Deansgate, Manchester; 129, Wellington Street, Glasgow; 7, Howard Street, Belfast.

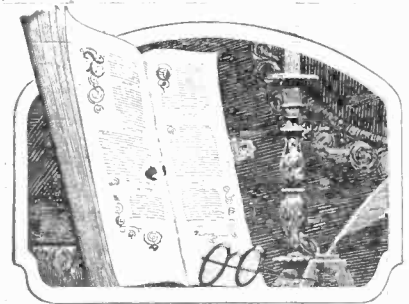

BOOKS

WITHOUT a doubt the very remarkable growth in the number of home-built Receiving Sets can be attributed to the exceptional Books and Magazines published by Radio Press, Ltd. This organisation—the largest of its kind in the world—has risen from quite modest beginnings because it was the first to realise that the crying need then, as now, was for dependable literature.

The moment a man gets really interested in Radio he is so fascinated that he immediately wants to learn more about it. Naturally he buys books and magazines—but let those books or magazines be too technical that he cannot understand and appreciate them, or let them contain inaccuracies or mis-statements and Radio loses another promising recruit.

Radio Press, Ltd., pursues a definite policy in its book publishing which can be summed up as follows:—

(a) It publishes Books written only by authors of repute. Its Editorial Staff—both in number and in experience the strongest in the country—is well able to check every manuscript submitted and to supervise generally the publication of every Book.

(b) Each Book selected for publication must fill a definite niche in the Radio Press Series. Just as there are many grades of wireless enthusiasts from novices to experienced experimenters so there must be various types of Radio Press Books. At the same time, however, every phase of the Science is covered so thoroughly that anyone can build up a complete library as his knowledge increases.

(c) Every Radio Press Book is printed in good style, profusely illustrated and represents particularly good value for money. While several of the more elementary ones are published at a cheaper price, the bulk of the Radio Press Series cost 2/6 e. ch. This price permits a very high quality being maintained and allows half tone illustrations and in the case of the constructional books, the fullest descriptions being given of every stage of Set building.

Make up your mind to look through the whole series at your Bookseller's or Wireless Dealer's—he has them in stock or will get them for you. It will be your first step to increased proficiency

—the extra few shillings that will give you a de-luxe Receiver

WITH perhaps a mistaken idea of economising, numbers of wireless enthusiasts when building their first Set have selected their components with praiseworthy care and ignored the importance of the panel. How absurd this is, will be apparent to all seasoned experimenters. They know perfectly well that even the most expensive components can only give a fraction of their effective results if the panel is permitting high frequency currents to leak in all directions.

So pay great attention to the panel and remember that even radio experts cannot tell the difference between various qualities of ebonite by merely looking at it. Your best safeguard, therefore, is to select Radion—every panel of which is guaranteed leakproof. Its beautiful polished surface (whether in black or Mahoganite) should not be removed. It will help to resist dust and moisture, both of which are enemies of clear reception.

Radion is the highest grade of insulation material in the world and has been specially developed for wireless use. Its use has been advocated by all the principal Magazines—indeed, you will find that Radion is recommended very extensively in most of the constructional articles recently published.

If an expert, therefore, uses and recommends Radion in preference to ordinary ebonite, you may be sure that it is exceptionally good.

Radion Sizes and Prices :

Size	Black	Mahoganite	Size	Black	Mahoganite	Size	Black	Mahoganite
6" x 7"	3/6	4/3	7" x 14"	8/-	10/3	8" x 26"	17/6	21/3
6" x 10"	5/3	6/6	7" x 18"	10/6	12/9	9" x 14"	10/6	12/9
6" x 14"	7/-	8/6	7" x 21"	12/3	15/-	10" x 12	10/-	12/-
6" x 21"	10/6	12/9	7" x 24"	14/-	17/3	12" x 14	13/3	16/-
7" x 9"	5/3	6/6	7" x 26"	15/-	18/6	12" x 21	19/9	24/3
7" x 10"	5/9	7/3	7" x 30"	17/9	21/6	14" x 18	19/9	24/3
7" x 12"	7/-	8/6	7" x 48"	28/-	34/6	20" x 24"	39/6	48/-

Special Note:—All $\frac{3}{16}$ in. thick—quite sufficient owing to Radion's tremendous strength.

RADION PANELS

American Hard Rubber Co. (Britain) Ltd.,
13a, Fore Street, London, E.C.2

From all Dealers

Gilbert Ad. 1939

Consult your Bookseller

Gilbert Ad. 1322

Silvertown

WIRELESS ACCESSORIES.

Quality guaranteed by over 50 years' electrical manufacturing experience.

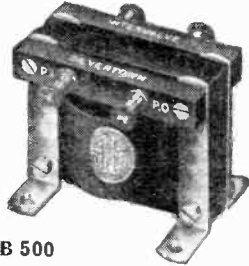

B 500

Interval Transformers.
Adopted by leading manufacturers of Wireless Receiving Sets and discriminating Amateurs in all parts of the World. Guaranteed for 12 months. Price 21/- each.



Filament Rheostats.
With finished and lacquered brass bush for panel mounting. Resistance wire wound on insulating rod, thereby giving perfectly smooth adjustment. Each supplied with diagram giving drilling dimensions.
3/6 each.



Ebonite Condenser Dials and Knobs.
In one piece, graduated in white, 0.180°, highly finished, complete with fixing screw, dial approximately 3 in. diameter. Complete, 1/3 each. Dials only, 10d. each.

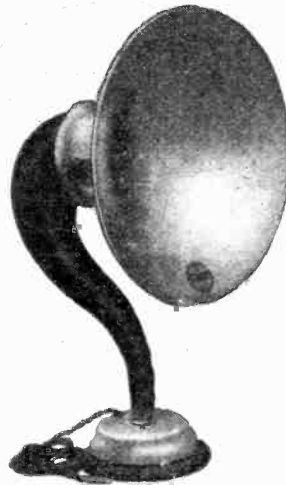

SILVERVOX LOUD SPEAKER

This instrument will reproduce both speech and music without the loss of its original tone and quality. Coils wound to either 120 or 2,000 ohms

The tone arm is a heavy aluminium casting.

Excellent strengths can be obtained on an efficient 2-valve receiver within 10 miles of broadcasting station.

Total height, 20 inches. Size of trumpet, 12½ inches diameter.

PRICE £3. 10s. EACH.

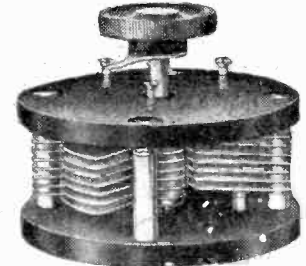

Variable Condensers.
(For panel mounting.)
Strongly constructed. Moving vanes are shaped to give low minimum capacity. Fitted with a stop to allow of a movement of 180° only.

From 5/6 each.

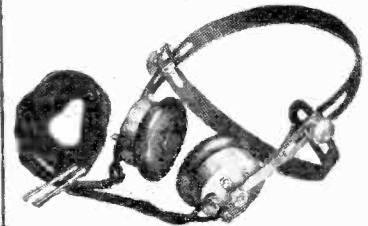

Telephone Headpieces.
The "Stalloy" diaphragms are matched so as to secure a balance of tone and quality. Resistance from 120 to 12,000 ohms. Price (4,000 ohms), 25/- each.

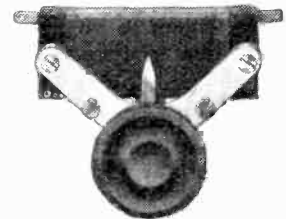

Potentiometers.
(For panel mounting.)
On rectangular ebonite former, complete with knob and pointer. Former mounted on cast brass frame. Resistance approximately 400 ohms. 7/6 each.

Makers : THE SILVERTOWN COMPANY,

106, CANNON ST., LONDON, E.C.4.

BELFAST : 75, Ann Street.
BIRMINGHAM : 15, Martineau Street.
BRISTOL : 4, Victoria Street.
CARDIFF : Pier Head Chambers, Bute Docks.
DUBLIN : 15, St. Andrew Street.
GLASGOW : 15, Royal Exchange Square.
LEEDS : 1, New York Road.



Works: Silvertown, London, E.16.

LIVERPOOL : 54, Castle Street.
LONDON : 100 and 102, Cannon Street.
MANCHESTER : 16, John Dalton Street.
NEWCASTLE-ON-TYNE : 59, Westgate Road.
PORTSMOUTH : 49, High Street.
SHEFFIELD : 88-90, Queen Street.

In replying to advertisers, use COUPON on last page

Brown

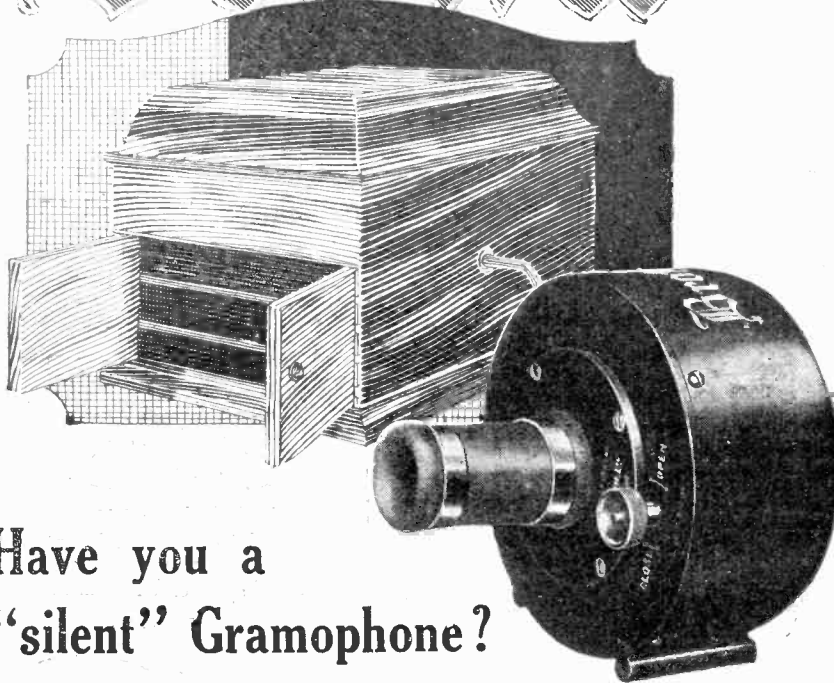

Have you a "silent" Gramophone?

WHY not convert your Gramophone—which probably is little used—into a first-class Loud-Speaker? Provided that it is of good design and manufactured by a reputable firm you will obtain excellent results from it. All that you need is a **Brown** Wireless Adaptor (in one of the two sizes described below) and a length of suitable flex.

To convert the Gramophone merely remove its sound box and fix the Adaptor. A rubber connection ensures that the Adaptor will fit all makes of machines.

In some cases when the H.1. type (illustrated above) is used it may be necessary also to lift off the turntable, but apart from this no alterations to the Gramophone are required.

Two minutes and your "silent" Gramophone is doing duty as a Loud-Speaker!

Remember that each of these two Gramophone Adaptors operates on the identical principles of the well-known **Brown** Loud-Speaker—the cone-shaped aluminium diaphragm and the tuned reed.

As a result the tone from your Gramophone will be most mellow and entirely free from distortion. Ask your Dealer to show you these Adaptors—you will appreciate that they are typical **Brown** products.

TYPE H.1. (as illustrated) Complete with flexible fitting.	TYPE H.2. Suitable for the room of average size.
120 ohms .. £4 7 6	120 ohms .. £2 0 0
2,000 ohms .. £4 10 0	2,000 ohms .. £2 2 0
4,000 ohms .. £4 12 0	4,000 ohms .. £2 4 0

Can be demonstrated at our Showrooms—

LIVERPOOL: 15, Moorfields. SOUTHAMPTON: 67, High St.
LONDON: 19, Mortimer Street, W.1.

S. G. BROWN, Ltd.—Victoria Road, N. Acton, W.3.

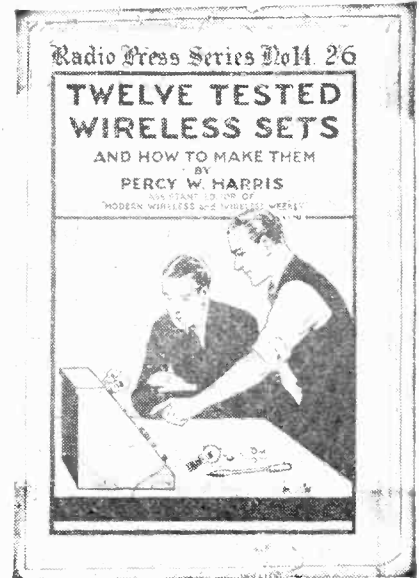

PROBABLY no writer of Books and Articles dealing with the constructional side of Wireless is more popular than Percy W. Harris. The reasons for this may be two-fold. Firstly, because he takes extraordinary pains to make every detail clear and intelligible to even the veriest novice. Secondly, because the Instruments he describes, although refreshingly original in design, give extraordinarily good results.

No reader of this book, "Twelve Tested Wireless Sets" by P. W. Harris, need be afraid that he does not possess sufficient skill to build one of his Receiving Sets or that elaborate tools are necessary. If he has sufficient patience to follow clear diagrams and explanations, and if he can handle intelligently the ordinary household tools, then success is assured.

ORDER A COPY TO-DAY.

PRICE 2/6 (Post Free 2/8).

Obtainable from all Booksellers, Newsagents and most Wireless Dealers, or direct from—

RADIO PRESS LTD.
BUSH HOUSE, STRAND,
LONDON, W.C.2.

"GOLTONE" (Regd.) WIRELESS RECEIVING SETS

British Made.

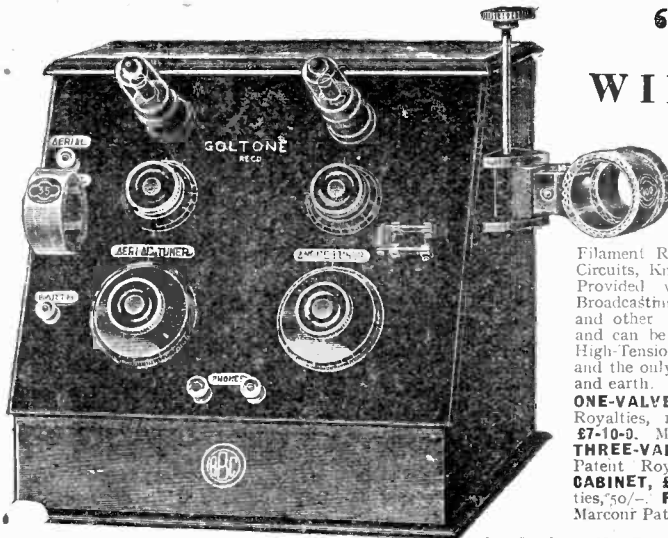

Elegant appearance. Highly selective. Simplicity in Tuning. Designed for receiving on any Wavelength. The Two-Valve Set clearly receives British Broadcasting and Continental Stations, and for Loud-Speaker Reception the Three-, Four- and Five Valve sets have proved entirely satisfactory in all parts of the Kingdom. Polished Cabinet (Removable back), Ebonite panel, fitted with Valve Holders, Filament Resistances, Condensers for Tuning Aerial and Anode Circuits, Knife Switch for High and Low Tension Circuits, etc. Provided with Plug-in Coils to receive all the British Broadcasting Stations. Plug-in Coils to receive Paris, Berlin and other high-wave stations are interchangeable and can be supplied. Both the Low-Tension and High-Tension Batteries can be fitted inside the Cabinet, and the only wires on view are the aerial and earth.

ONE-VALVE SET, £2-18-0. Marconi Patent Royalties, 12/6. **TWO-VALVE CABINET, £7-10-0.** Marconi Patent Royalties, 25/- **THREE-VALE CABINET, £10-10-0.** Marconi Patent Royalties, 37 6. **FOUR-VALVE CABINET, £13-10-0.** Marconi Patent Royalties, 50/- **FIVE-VALVE CABINET, £19-10-0.** Marconi Patent Royalties, 62/6.

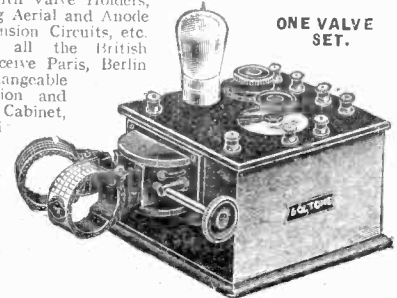

ONE VALVE SET.



"GOLTONE" WAVE TRAP.

An extremely effective instrument, when used in conjunction with a variable Condenser coos, for eliminating signal interference up to 600 metres. Easily attached.
No. R5 750.
12 6 each.
As illustrated, fitted in polished case, Ebonite Panel, ready connected with variable Condenser.
No. R5 1057.
32 6

See Catalogue No. R. 111 for full details together with particulars and prices of above Sets for "Home Construction."

Large fully illustrated 32 pp. Radio Catalogue post free on request. Enclose business card for Trade Terms.

These sets are stocked by Houghton's of London and all Branches, and by the Leading Radio Stores. Write direct if unobtainable.



Address all communications to Head Office and Works: **PENDLETON - MANCHESTER**
Stocks also held at Glasgow Depot, 95, Pitt Street

BRITISH-MADE LOUD SPEAKERS.

Excellent finish. Represents the best possible value.

"GOLTONE" CONCERT GRAND.

14 in. Bell mouth, 22 in. high. Unequaled for volume of sound and purity of tone. Complete with Cords. 2,000 ohms.
£4 0 0

"GOLTONE" JUNIOR.

9 in. Bell mouth. 16 in. high. Complete with Cords. 2,000 ohms
£1 10 0



ASK YOUR DEALER FOR

TROLITE PANELS and Moulded Parts.

A GOOD SET DESERVES A GOOD PANEL.

A Trolite Panel Offers You the Following Advantages:

- i. Beautiful appearance, due to the finely polished surface which does not harbour dust and is guaranteed free from surface leakage.
- ii. Highest insulation. There are many grades of ebonite, but only one of Trolite—the best.
- iii. Freedom from any tendency to discolour under the action of light.
- iv. No absorption of moisture—therefore no decrease of insulation in a damp atmosphere.
- v. Great mechanical strength combined with ease in sawing and drilling.

Only TROLITE offers ALL these Advantages.

WHOLESALE AGENTS.

SCOTLAND: J. CORSTON SINCLAIR & Co., LTD., 47, Waterloo Street, Glasgow.

IRISH FREE STATE: THE EIRCO WIRELESS ENG. CO., LTD., Westmorland Street, Dublin.

ULSTER: THE ELECTRICAL INSTALLATION & REPAIRING Co., LTD., 40, Berry Street, Belfast.

LANCASHIRE & CHESHIRE: HERBERT A. PRATT, Lords' Chambers, Liverpool Road, Manchester.

YORKSHIRE: E. HARPER & Co., LTD., 8-14, Manchester Road, Bradford.

NORTHUMBERLAND, WESTMORLAND & DURHAM: UNITED METAL ENGRAVING Co., LTD., 40, High Bridge, Newcastle-on-Tyne.

MIDLANDS: S. A. CARTY, 125, Anderton Park Road, Moseley, Birmingham.

WALES: WATSON BROS., 48, Dock Street, Newport, Mon.

F. A. HUGHES & Company, Limited, 204-206, Gt. Portland St., W.1

Telegrams: "Distancing, V'esdo, London." Telephone: Museum 8630-2 (3 lines).

In replying to advertisers, use COUPON on last page

The simplest way of enjoying Loud Speaker pleasures

If your receiver gives really good signals in the headphones, it's a perfectly simple matter to add the comfort of a Loud Speaker. All you need to do is connect the "Sparta" Amplifier to your present set, slip leads to the Little "Sparta" Loud Speaker—and the result is Loud Speaker reception as only "Sparta" products can provide it. Rich, pure reproduction—ample volume—and absolute reliability.

The "Sparta" Amplifier. One Valve.

Designed for .06 amp. Dull Filament valves. Constructed with the well-known "Sparta" components, including the famous Type "B" Ironclad Transformer, ensuring great amplification combined with distortionless reproduction. Full instructions for use are supplied in the case and each set is fully guaranteed. **63s.** (plus Royalty 12/6.) Valve and Batteries extra.

The Little "Sparta" Loud Speaker.

A small brother of the famous "Sparta." Made in three types, 120, 2,000 or 4,000 ohms resistance, adjustable diaphragm control, **55s.**

FULLER'S UNITED ELECTRIC WORKS, LIMITED,
Woodland Works, Chadwell Heath, Essex.

Phone: Ilford 1200 (6 lines).
Telegrams: Fuller, Chadwell Heath.
LONDON DEPOT: 58, High Street, W.C.2. Phone: Gerard 5070.
Send for Lists Nos. 325 and 326.



HIGH-GRADE COMPONENTS

are World-Famous

Our standard receiving apparatus is used in every quarter of the Globe, and our components are in demand everywhere. We have a set or component for every requirement. For efficiency insist on M. H. Products.

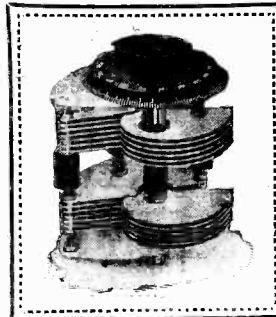

DUAL CONDENSERS

Dual Condensers are essential for the perfect handling of sets in which two stages of High Frequency Amplification are employed. M.H. Dual Condensers are, of course, up to the high efficiency standard of all M.H. products, and embody the refinements quoted below under the heading Square Law Condensers. M.H. Dual Condensers are specially suitable for using with 2 M.H. Plug-in Transformers in tandem.

Capacity 0.0003. Price 19/-

SQUARE LAW CONDENSERS

With or without a single plate vernier attachment. The advantages of the Square Law type of condenser are, of course, well known, the variation of capacity being even over the whole range of the dial.

Aluminium plates—Well Insulated—Perfectly spaced—Smooth and delicate movement—Simple to fix—Drilling template and zero indicator supplied with each.

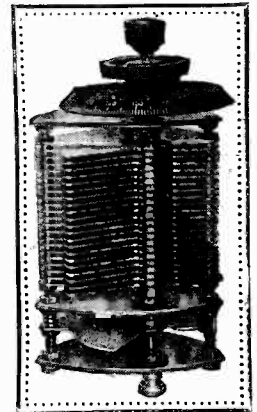

PRICES		
	Vernier.	Plain.
0.001 μ F.	17/6	11/6
0.0005 μ F.	15/-	10/6
0.0003 μ F.	14/-	8/6
0.0002 μ F.	12/6	7/6

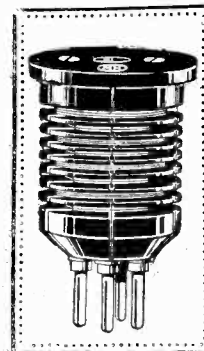

H.F. TRANSFORMERS

A series of H.F. plug-in transformers in six ranges of wavelength. They are made of our highly-polished non-loss chromite. The windings are carried in staggered slots, well protected, ensuring low self-capacity and high efficiency. Each and every transformer is tested to a standard oscillation and any not coming within very narrow limits are rejected. Perfect matching is thus ensured.

No. 00.	80 to 150 metres	10/-
No. 0.	150 to 300 metres	10/-
No. 1.	300 to 600 metres	10/-
No. 2.	550 to 1,200 metres	10/-
No. 3.	1,100 to 3,000 metres	10/-
No. 4.	2,500 to 7,000 metres	10/-
The Complete Set (Nos. 00 to 4.)		55/-

Can be supplied in matched pairs at NO extra charge if requested at time of ordering.

L.M^c MICHAEL LTD
IN CONJUNCTION WITH B. HESKETH LTD

WIRELESS ENGINEERS,

Radio Corner, 179, Strand, London, W.C.2.

HUNT'S NEW CRYSTAL ACCESSORIES

Fig. No. 922.

MICROMETER ADJUSTMENT
(without moving catswhisker or cup).

LOCKING SCREW. DUSTPROOF GLASS CYLINDER.

Fig. 1100. Variable Grid Leak Top Panel mounting. Each valve repeatable. Standard resistance 4-5 megohms. Other resistances to order; no extra.

Price 4/6 each.
Anti-capacity handle gd. extra

Manufactured by
A. H. HUNT. LTD.

DETECTOR
Codeword: "VERNIER."

CATSWHISKER OR DOUBLE CRYSTAL
(spare cup with 3 screws supplied free).

PRICE 4/- EACH.
Complete as illustrated, but less Crystals.

Fig. 1102. Variable Grid Leak as Fig. 1100, but under panel mounting
Price 5/- each.
Anti-capacity handle gd. extra.

(DEPT 5) H.A.H WORKS
TUNSTALL RD., CROYDON
"KEYAGE, CROYDON."

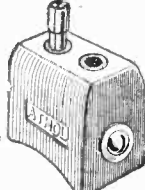

ATHOL PORCELAIN COIL MOUNT

With the perfect plug. Will fit any coil.

1/- each.



ATHOL COIL RECEPTACLES

For anode coils, 'phone plugs, battery plugs, etc.

Moulded 1/- Ebonite 1/3

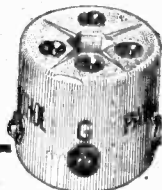

ATHOL REVERSIBLE VALVE HOLDER

The only single hole fixing holder that fits any set.

1/3 each.

ATHOL ENGINEERING CO.
CORNET ST., HR. BROUGHTON, MANCHESTER. FREE

HIGH FREQUENCY THE WINNER IS SPOTTED AND NOT ADVANCED IN PRICE.

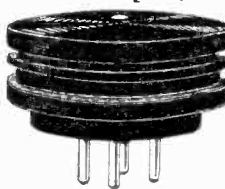

White Spot from	180 m.	5/-	} 35/-	PER SET
Red	300 m.	5/-		
Blue	500 m.	5/9		
Yellow	900 m.	6/6		
Green	1500 m.	7/9		
Mauve	3000 m.	8/9		

Matched Pairs No Extra.
Spot Transformer. Primary tuned with .0003 V.C.
Ebonite—Not Composition. No visible Connections.
A PERFECT COMPONENT PERFECTLY FINISHED.
Diagram of connections sent with each Transformer.
Any Dealer or Direct—

SPOT COMPONENTS CO.,
66, Highfield Road, Chorlton-cum-Hardy, Manchester
TRADE TERMS ON APPLICATION.

THE IDEAL CRYSTAL

For Distance, Volume or Reflex Circuits.

A Super Crystal Triple Tested.



Loud—
Clear—
Ever—
lasting.

EACH crystal is fully tested and guaranteed. A spiral contact of a special alloy is included, and we recommend its use, although this crystal will function with any wire contact or with zincite as a perikon detector.

Obtainable from all Wireless Stores, or post free from any of our addresses below.
Sealed Boxes, 2/6 each.

ROSE BROS. Electrical Co., Ltd.

London: 25, Milton St., E.C.1
Glasgow: 194a, St. Vincent St.
Manchester: 25-27, Miller St.
Bristol: 83a, Redcliffe St.

London Agent.
J. V. MULHOLLAND
4, Blenheim St., New Bond St., W.1.

S.S.A.

—BUT, OF COURSE, I USE GAMBRELL COILS.



This is usually the explanation as to why the other man always gets such excellent results. You, too, can benefit by Gambrell's research and experience. Write for the pamphlet on "Efficiency" Inductances and then consult your dealer. He will be pleased to supply you, for he likes handling really good apparatus.

THE COIL THAT IS DIFFERENT.

London Agent.
J. V. MULHOLLAND
4, Blenheim St., New Bond St., W.1.

GAMBRELL BROS., LTD.

76, VICTORIA STREET, LONDON, S.W.1.
Works: MERTON ROAD, SOUTHFIELDS, S.W.18.
Phones: VICTORIA 9938; PUTNEY 3641-2.

Cut out the noises

Cracklings, atmospherics, and other interruptions can be eliminated by using Exide Accumulators instead of Dry Batteries for High Tension supply.

Exide

THE LONG-LIFE BATTERY

MADE IN THE
LARGEST BATTERY WORKS
IN THE BRITISH EMPIRE.

EVIDENCE

Mr. H. Bacon, Sutton Scarsdale, Chesterfield, who in 1923 received a complete programme from W G Y, writes:—

"I have tested with Dry Batteries but there is not the clearness or sharp tuning I can get with your batteries."

Mr. E. C. Davies, who listened-in to the Firpo-Wills fight, says:—

"H.T. must be absolutely silent, and lengthy experiments have led me to the conclusion that up to now you make the only battery that is of the least use for this work."

Type BK in Units of 24 Volts cost 1/- a volt
Types AYG and RG 1 cost:—

	32 Volts	48 Volts	60 Volts
RG 1	£4 10 0	£6 10 0	£8 0 0
AYG	£5 10 0	£8 0 0	£9 15 0

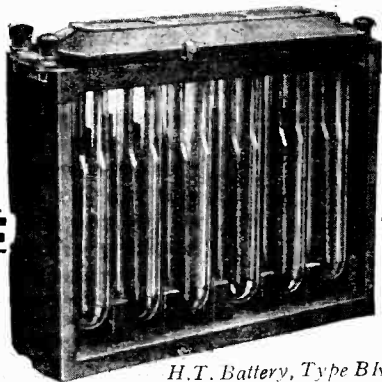

H.T. Battery, Type BK.
24 Volts.

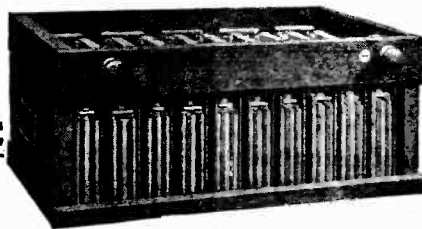

H.T. Battery, Type 30-AYG-1,
60 Volts.



H.T. Battery,
Type RG1. 60 Volts.

Showrooms and Depots:

LONDON:

219-229, Shaftesbury Avenue, W.C.2.

BIRMINGHAM:

58, Dale End.

Manufactured by

THE Chloride ELECTRICAL STORAGE COMPANY LIMITED.

at CLIFTON JUNCTION, near MANCHESTER.

Showrooms and Depots:

BRISTOL:

22, Victoria Street.

MANCHESTER:

1, Bridge Street.

HUNT'S NEW MODEL HEADPHONES



SOLID NICKEL SILVER headbands and supports with slides. Adjustable in every direction. Highly polished finish and very strong. **HYGIENIC & CLEAN.** No webbed or fabric band to collect dirt or germs.

Fig. 970.—VALVEHOLDER. Codeword "KOLLER." Complete as illustrated with 8 nuts and washers. Price 1/3 each.

Write for Free Catalogue and Leaflets.



**"Powerful,
Clear Re-
production."**

Fig. 1312.

"GOODTONE"

**LIGHTWEIGHT
HEADPHONES,**

4,000 ohms resistance.

Price 17/6 per pair.



Fig. 429.—One-way Screw Down SWITCH, to control L.T. Current.

Price 2/- each.

A. H. HUNT, LTD.
(Dept. 5), H.A.H. WORKS, RUNSTALL ROAD,
CROYDON

T. O. BUSS

SCIENTIFIC INSTRUMENT MAKER

77, Clerkenwell Rd., London, E.C.1

Estb. 1850. Exhibition Awards: London, 1862; Sydney, 1879; Melbourne, 1880.

INTERVALVE TRANSFORMERS

Made like an Instrument by a Scientific Instrument Maker.



Correct priming impedance. Wound with correct gauge and quantity of wire. Heavy iron core to give good magnetic field—and will carry heavy currents.

**PRICE
18/6**

Ratio 5 to 1.

MADE LIKE AN INSTRUMENT.

This instrument is thoroughly tested and is **GUARANTEED FOR TWO YEARS.**

Barclays 353

LITTLE THINGS

Appear often to be sent to try us. For example, when you begin work on your new panel and find you want some special "Gadget"; or that you have made no provision for a suitable cabinet, you can obtain **PEACE OF MIND** by falling back on our service. We can supply all

PANELS, CABINETS AND ACCESSORIES

AS DESCRIBED FROM TIME TO TIME IN
THE RADIO PRESS.

Send 2d. stamp for List and Leaflets.

"S. A. CUTTERS,"

15, Red Lion Square, London, W.C.1.

Telephone: Chancery 8042.

A Standard Instrument



Price **12/6**

Nothing Better Made
The **SUMMIT MANUFACTURING CO.**
Gladiator Street, Brockley Rise,
London S.E.23.

It is no longer necessary to pay exorbitant prices for Low Frequency Transformers. The "Supreme" is equal in every respect to instruments sold at twice the price. It does not distort and gives the maximum amplification. We guarantee its reliability.

The increased range, purity of reception and amplification produced by "Supreme" Transformers will astonish you.

It's well worth while insisting on "Supremes"—obtainable at Dealers everywhere.

If not obtainable in your district, write sending name and address of your dealer.

"SUPREME"

Perfectly simple and simply perfect

THE MIC-MET SUPER CRYSTAL DETECTOR

[REGD.] (PATENT NO. 221943.)

This instrument is micrometrical in principle and ensures a perfectly adjusted and rigid contact between crystal and contactor. By a combination of movements between the three knobs, any portion of the exposed part of the crystal may be contacted. For S.T. 100 and other circuits employing crystal rectification, the most efficient detector to use is the **MIC-MET**. Can be obtained from your local wireless dealer or direct from the manufacturers on receipt of 6s. P.O. Trade enquiries solicited.

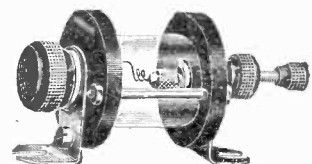

British Make.

Beware of imitations and infringements.

C. & J. ARRIGNONI & CO., LTD., COMPTON PASSAGE, CLERKENWELL, LONDON, E.C.



The Portable Accumulator for Dull Emitters.

WHEN Dull Emitters first came on the market a new era was announced. The accumulator was to be relegated to the Dark Ages and all valves would be run from Dry Batteries. This happy state of affairs, however, has not been realised. The Dry Battery has not proved itself to be the ideal method of lighting the filaments of Dull Emitters.

On the contrary—wireless enthusiasts now know that the Dry Battery fluctuates in output so much that good reception is impossible. Apart from this, of course, Dry Batteries are a perpetual expense.

The new portable Oldham Accumulator is so small that it can be placed in the pocket, and yet its output—for its size—is so high that it will run a 2-Valve Set using Wecos, Wuncells or 1-volt Oras for 25 hours on a charge. For '06 Valves, two of them in series will run an S.T.100, for instance, six weeks on one charge. Whereas a Dry battery, when exhausted, must be discarded, an Oldham Portable costs only a few coppers to be recharged. Go to your Dealer to-day—if he is out of stock give us his name, and we will see that he gets a stock at once.

Reverse it—shake it and still the acid won't fall out—

The Oldham "Non-Spill," constructed of best seamless celluloid with large terminals and a screw vent. Absolutely non-spillable. Plates manufactured under the exclusive Oldham Special Activation Process. 2-volts 10 amp. hours continuous.

12/6

OLDHAM & SON, LTD.,
DENTON, MANCHESTER.
LONDON: Gt. Chapel St., Oxford St., W.1.
NEWCASTLE: 1, St. Mary's Place.

Other Oldham Accumulators:

Type	C L	2 volts	10 amps. hrs.	continuous	£	s. d.
2					8	9
4					17	6
6					1	6 3
2					11	1
4					1	2 2
6					1	13 3
2					16	1
4					1	12 2
6					2	8 3

From all Dealers.

THE BOOKS for Beginners and Experts

The Radio Press Series.

No.	Price
1	9d.
1	Wireless for All
	By John Scott-Taggart, F.Inst.P., A.M.I.E.E.
2	1/-
2	Simplified Wireless
	By John Scott-Taggart, F.Inst.P., A.M.I.E.E.
3	1/6
3	How to Make Your Own Broadcast Receiver
	By John Scott-Taggart, F.Inst.P., A.M.I.E.E.
4	2/-
4	How to Erect Your Wireless Aerial
	By B. Mitchell, A.M.I.E.E.
5	1/6
5	The Construction of Wireless Receiving Apparatus
	By P. D. Tyers
6	1/6
6	The Construction of Crystal Receivers
	By Alan L. M. Douglas
7	2/6
7	How to Make a "Unit" Wireless Receiver
	By E. Redpath
8	1/6
8	Pictorial Wireless Circuits
	By Oswald J. Rankin
9	2/6
9	Wireless Valves Simply Explained
	By John Scott-Taggart, F.Inst.P., A.M.I.E.E.
10	2/6
10	Practical Wireless Valve Circuits
	By John Scott-Taggart, F.Inst.P., A.M.I.E.E.
12	2/6
12	Radio Valves and How to Use Them
	By John Scott-Taggart, F.Inst.P., A.M.I.E.E.
13	2/6
13	500 Wireless Questions Answered
	By G. P. Kendall and E. Redpath
14	2/6
14	12 Tested Wireless Sets
	By Percy W. Harris
15	3/6
15	More Practical Valve Circuits
	By John Scott-Taggart, F.Inst.P., A.M.I.E.E.
16	2/6
16	Home-Built Wireless Components
	By E. Redpath
17	2/6
17	Wireless Sets for Home Constructors
	By E. Redpath
18	1/6
18	Tuning Coils and How to Wind Them
	By G. P. Kendall, B.Sc.

RADIO PRESS PANEL CARDS.

1	1/-
1	How to Make the W.I. Receiver
	By Herbert K. Simpson

SIMPLEX WIRING CHARTS.

1	1/-
1	For 2-Valve Set
2	1/-
2	For 3-Valve Set
3	1/-
3	For 4-Valve Set

RADIO PRESS WIRELESS PANEL TRANSFORMERS

5s.
5s.

"MODERN WIRELESS" COIL TABLE

6d.
6d.

RADIO PRESS ENVELOPES.

1	1/6
1	How to Build an S.T.100 Receiver
	By John Scott-Taggart, F.Inst.P., A.M.I.E.E.
2	2/6
2	How to Build a 4-Valve Receiver
	By Percy W. Harris
3	2/6
3	How to Build the "Simplicity" 3-Valve Set
	By G. P. Kendall, B.Sc.
4	2/6
4	How to Build the All-Concert-de-Luxe Receiver
	By Percy W. Harris
*8	1/6
*8	How to Make a 1-Valve Reflex Receiver
	By Herbert K. Simpson
*9	1/6
*9	How to Build an Efficient Single-Valve Set
	By Herbert K. Simpson

The Radio Press Envelopes are the most complete guide to wireless construction ever devised. They contain exact size panel and wiring blue prints, complete working drawings, sheets of instructions regarding construction and working lists of components and many photographs on beautiful art paper showing the set and wiring from every possible angle. Every possible detail is explained and you cannot go wrong.

* Just Published

Any of the above publications can be obtained from principal wireless dealers and through any bookseller—or direct (plus 2d. postage, or, on Radio Press Envelopes 3d.) from

RADIO PRESS LTD.
BUSH HOUSE, STRAND,
LONDON, W.C. 2.

Barclays Ad.



Gilbert Ad. 1938



Manufactured only by
Portable Utilities Co. Ltd.,
Fisher Street, London, W.
Sold by all Dealers.

Made in two types:
Concert Grand .. 30/-
Eureka No. 2 (for
L.F. Stage) .. 22/6

The magnificent Eureka

IT is human nature for all of us—even though we may not be blessed with riches—to want to possess things recognised as the finest of their kind.

The wealthy man owns his Rolls Royce because the whole world knows that it is the finest car. Perhaps it is only a bicycle—a watch—or a fountain pen . . . but a time comes when we say “when I can afford it I shall buy a — because everyone knows there is no better.” And wireless enthusiasts are looking upon the Eureka in much the same way. We know that to many the outlay of 30/- is an appreciable sum. To them we express our regrets. The superior quality of all the materials used in a Eureka, and the more costly methods of manufacture, precludes any idea of producing it at a lower price.

Indeed, we know that no Eureka user would wish to see the price reduced if it meant sacrificing even one of its many exclusive advantages. If wireless enthusiasts could but see the extravagant care taken during every stage of manufacture—if they could but see the tests that each individual Transformer has to undergo successfully—they would well understand why we are able to guarantee every Eureka to give *years* of service.

No better Transformer made than a Eureka

In replying to advertisers, use *COUPON* on last page

Gilbert Ad. 1957.

1005

BONZO, tickled by John Henry. You will wear an equally happy expression if you also wear "**BONTONE**" Phones, Britain's best. Backed by a generous guarantee. Sensitive, Durable, Comfortable and beautifully finished.

MANUFACTURED ENTIRELY BY BRITISH LABOUR.
Up to a high efficiency and down to a low and popular price.



"**BONTONE**"
Lightweights 15 6
"BONTONE"
Originals 14 6
4,000 ohms per pair.
Post Free.

An assurance for all time:—
We agree to replace any Phones not giving complete satisfaction, if returned to us within 7 days of purchase, undamaged. We further agree to repair, adjust and retest any "**BONTONE**" Phones irrespective of the date of purchase, for the sum of 3/- plus 6d. postage, if returned to us intact with remittance.
This is our Bond; compare same with the risk entailed when purchasing foreign made Phones, which may be dear at any price. Insist upon purchasing "**BONTONE**" Phones, avoid substitutes and you will increase your wireless pleasures and reduce your wireless worries.

May be purchased from all Electricians, Wireless Dealers, and Stores or direct from:
B. D. & Co. (EDWARD A. BOYNTON)
Works: GOSWELL ROAD and CITY ROAD, LONDON, E.C.1.
Offices: 167-173, GOSWELL ROAD, LONDON, E.C.1.
Admiralty, War Office and India Office Contractors.

CHALLENGE CRYSTAL SETS

No. 40. A new Radiax production. Designed and built on entirely new principles, it is the result of much experiment and test, our object having been to obtain the utmost power of which a crystal set is capable. Range 300 to 500 metres. PRICE £2/2/-.

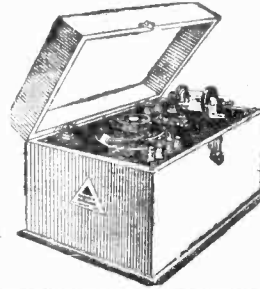

NO. 41. LONG WAVE.
(100-1,780 metres). Uniform with No. 40, but incorporates the Radiax Universal principle and enables, by means of a switch, perfect results to be obtained on the lower wave band or on the new 1,600 metre High Power Station. PRICE £2 10 -.
Write for List of full range of Radiax Universal Receivers, 1, 2, 3, and 4 values. Complete or for Home Construction.

RADIAX Ltd.
40, Radio House, Percy St.,
Tottenham Court Road,
London, W. 1.



Barclays 500.

H. T. EFFICIENCY AS IT "WASNT ON WEDNESDAY"

Asked the meaning of the word revolution, a small boy said that it was "something on Saturday as it wasn't on Wednesday." "**Hovimo**" Connectors are a revolution in H.T. Efficiency. Their use avoids soldering and cheapens cost of complete battery from 25 per cent. to 50 per cent. The "**Hovimo**" also ensures perfect "silent" working, is everlasting, allows easy replacement of units will take ordinary wander-plug, and makes it possible to keep your H.T. at an equal voltage... British Made.

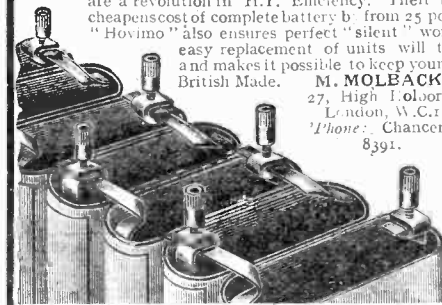

M. MOLEBACK,
27, High Holborn,
London, W.C.1.
Phone: Chancery
8391.

Ask your dealer for them

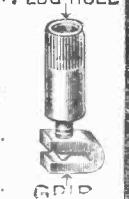

1/6

Per Poz. From dealers or direct.



FIXED CONDENSERS

Guaranteed within 5% of stated capacity, this accuracy has never before been obtainable by the public. Buy one. Test one. It will prove our statements and thoroughly satisfy you.

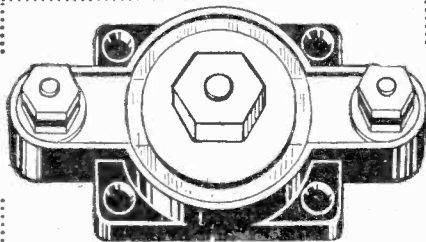

FEATURES: Reliability of Capacity. Finest grade ruby Mica Di-electric. Highest quality Copper Foil. Adapted for Terminal or soldered connections.

CAPACITIES:
.001 to .0005, Price 1/3 each.
.002 to .006, Price 2/- each.

If your local dealer cannot supply Finston components, send your order to us together with his name and address.



Another trustworthy component. Extremely moderate price. Ebonite stator, high-grade ebonite moulding rotor, engraved dial and knob. Price 5/6

SQUARE LAW CONDENSER

Aluminium top and bottom plates, high-grade ebonite composition knob and dial, cleanly engraved 0-180. Varies 98 per cent. pure aluminium.

PRICES.

.001	9/-
.00075	8/6
.0005	8/-
.0003	7/6
.0001	6/6
.00005	6/-

LIGHTING SUPPLIES COMPANY
2, FINSBURY AVENUE, LONDON, E.C.1

Barclays 476.

ACCUMULATORS RE-CHARGED FREE IN YOUR OWN HOME.

and from your ordinary electric installation, where you have **DIRECT CURRENT** 100 volts. to 250 volts. The "**CHASEWAY**" **CHARGER** (D.C.) can be connected by the merest amateur and requires no attention. It saves its cost quickly by doing away with the re-charging expense, besides avoiding that last minute "let down" and all the usual accumulator trouble. Whilst you are using the current for lighting, ironing or any other purpose the "**CHASEWAY**" automatically re-charges your accumulator free.

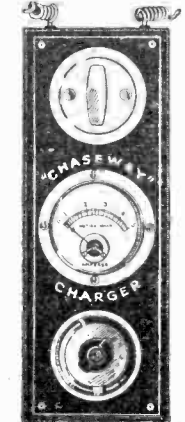

Conforms to conditions of Supply and Insurance Companies
ASK YOUR DEALER FOR IT OR
Send 25/- for the simplest, neatest and most practical job on the market, complete with explicit fixing instructions and diagram. Size 9in. by 3in.

THE CHASE ELECTRICAL MANUFACTURING CO. Ltd.,
184c, FLEET STREET, LONDON, E.C.4.
Trade Enquiries Invited. V.P.

ONLY 25/-

don't pay more

440,000 wireless enthusiasts regularly buy the three leading Radio Press publications—
MODERN WIRELESS, WIRELESS WEEKLY
and the
WIRELESS CONSTRUCTOR.

Manufacturers and Retailers not represented in the advertisement pages of these should apply at once for advertisement rates. Write to Rates Dept. :—

BARCLAYS ADVERTISING LTD.
BUSH HOUSE, STRAND, LONDON, W.C.2.

NO MORE "SEARCHING"

A Station Indicator enabling you to select any station in your range immediately. Wave length, call sign, name of station clearly indicated—fix this in place of the ordinary dial or scale. Suitable both for square law and plain condensers.

3 1/2 in. diameter. White or black.

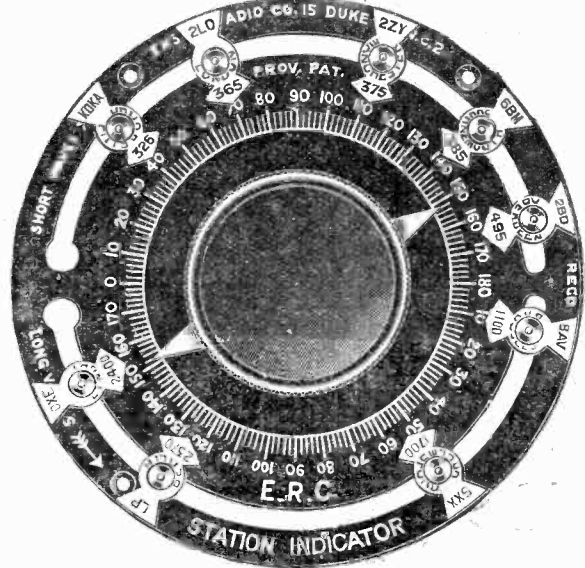

4/6 each post free without station arrows. Station arrows 3/- per dozen. State stations required.

ENSIGN RADIO CO.
15, Duke St., W.C.2. Opposite
East side Charing Cross Station.
Gerrard 6703.

When fitting an Earthing Switch for the ARGUS LIGHTNING PROTECTOR

All users of Wireless know well the importance of installing some substantial device to prevent natural electrical disturbances from destroying their wireless installations. The "Argus" is the most efficient earthing switch, and enables listeners-in to use their sets in perfect safety, even during a thunderstorm.

Price complete with instructions. Post 3d. **2/9**

Obtainable from all Wireless Dealers, or direct from
ANDERSON'S Wireless Sales Agency.
9-15, Oxford Street, W.1.

Telephone: Gerrard 1749. Telegrams: Anwisalg. Westcent. London

CARPAX Tested Specialities for RADIO Enthusiasts.

GOLD SEAL HOMCHARGER

Charges the Battery while you sleep!

Is a Necessity to every Wireless Enthusiast. Charges any Radio Battery overnight from an A.C. Supply for a few coppers. (D.C. Types also available). Maintains the Batteries always in TIP-TOP Condition and ensures **MAXIMUM SIGNAL STRENGTH.** From most dealers or direct from us **£7-10-0**

CARPAX COMPANY LTD.,
312, Deansgate, Manchester.

Free List

2. EFESCA VER-NISTAT (Pat. applied for). Of unique construction, the Vernistat gives extremely delicate control and is smooth and silent in operation and is specially suited to High Frequency and Detector Valve filament control. Resistance 5 ohms, 6/- each, complete as illustrated.

3. EFESCA VARIABLE CONDENSER gives a high standard of accuracy. Vanes are spaced with micrometer exactitude, the construction providing smooth action coupled with stability. One-hole fixing. .001 mfd. 12/6, .005 mfd. 8/6, .0005 mfd. 7/-, .00005 mfd. 5/8

Ask your Wireless Dealer to show you

EFESCA

One-Hole Fixing Components

Your wireless dealer or electrician will be pleased to show you EFESCA components. Ask his opinion of them, and he will tell you that EFESCA components are made with instrument-maker's precision and so give the maximum efficiency—the purest tone and greatest volume of sound—in the hands of the amateur constructor.

EFESCA components are mounted by our Standard One-hole Fixing, which greatly simplifies panel drilling; write for Catalogue 522/11—it is free and full of interest.

Wholesale only—
FALK, STADELMANN & CO., LTD.

Efesca Electrical Works, 83-85-87, Farringdon Road, LONDON, E.C.1

and at
Glasgow, Manchester and Birmingham.

Wireless List "F"
Post Free

Price **10/6**
Postage 6d.

The "Gramaphix" Loud-Speaker

A most efficient device to which ordinary headphones are clipped by simple pressure on the spring clips.

The Gramaphix requires (according to distance from the Broadcasting Station) at least one stage of low-frequency amplification to give satisfactory volume.

HORNS TO MOUNT ON GRAMAPHIX:
Straight Horn (Bell 10 in.) 6/-, Swan-necked Horn (Bell 11 1/2 in.) 15/-, Small Curved Horn (Bell 8 1/2 in.) 7/6; Post 8d. extra.

RICHARD MELHUISS, Ltd.,
50/51 & 84 Fetter Lane, London, E.C.4 Est. 1828
Electrical Engineers and Wireless Experts.

Ask your LOCAL RETAILER for the **"SIMPLEX"**

Lead-in Strip. No holes to bore, no tools required.
1/6. Postage 2d.

THE **"MORRIS"** (all-steel) Valve Template. Saves **TIME, TEMPER** and **EBONITE.**
10 1/2d. post free.

J. O. NICHOL & CO.,
46, Lancaster Avenue, Fennel St., Manchester. Tel. City 1760.

Would you board a bus without first looking for the number?

Never! Well, for the same reason we ask you to look for the name "ORMOND" on your purchase if you wish to secure a GENUINE "ORMOND" PRODUCT—a little trouble but well worth it in the long run. Beware of imitations—take no substitute—the name is your guarantee—look for it on every "ORMOND" PRODUCT.



We specialise in turning Brass and Steel Screws and Machined Parts and Accessories of all descriptions.

All Cheques and Postal Orders should be crossed and made payable to The Ormond Engineering Company.

25 Years' British Manufacturing Experience.

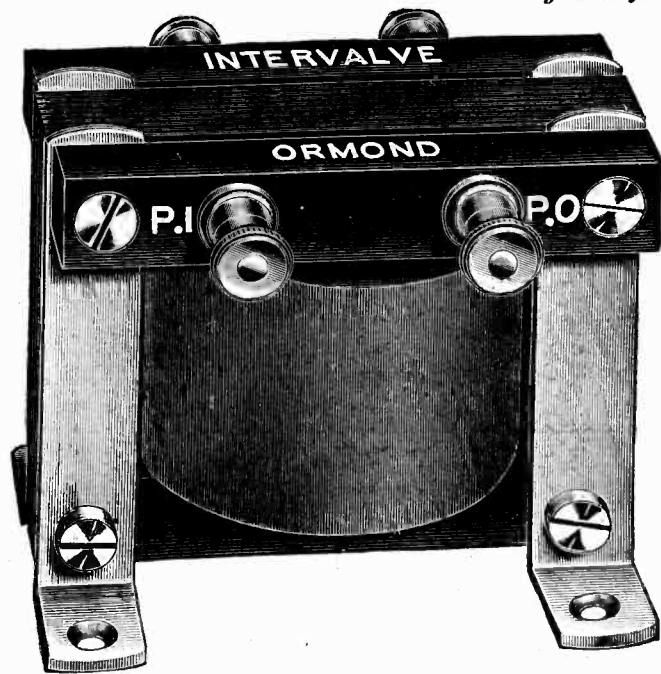

Audio Frequency Transformers

RATIO 5 to 1 or to order. Suitable for general low frequency and power amplifying work. **PRICE 15/- EACH**

THESE TRANSFORMERS are the result of extensive research, and particular attention has been given to the elimination of objectionable resonance throughout the entire range of audible frequencies. The use of grid cells is strongly advised, and a suitable method of connection is described under.

PRIMARY. It is recommended that the primary winding be shunted with a fixed condenser; a suitable value is:—

.0015 μ F.P.I. to + H.T. P.O. to Plate.

SECONDARY. S.I. to Grid. S.O. to negative side of grid cells. Positive side of grid cells to negative low tension. A two or three-cell dry battery will suffice in most cases. For special valves, consult data supplied by the Manufacturer.

Write for our New (1925) Catalogue. TRADE TERMS ON REQUEST.

ORMOND ENGINEERING CO.

199-205, Pentonville Road, King's Cross, London. N. 1.

'Grams: "ORMONDENGI, KINCROSS."
'Phones: CLERKENWELL 9344 (3 lines).
FACTORY: Whitkin Street, Clerkenwell.

Was yours an Amplion Christmas



Happy Hours

THROUGH the unique "personality" of the Amplion Loud Speaker—a characteristic product of the House of Graham—scores of thousands of homes enjoyed "an Amplion Christmas"—in other words—the full delights of *Better Radio Reproduction*.

Was yours an AMPLION Christmas, too? If not, there are still many happy hours in store for you in the New Year, because the AMPLION, whenever it is associated with a reasonably good and properly-tuned receiving set, makes wireless reception an entertainment that all may enjoy without the least evidence of mechanical "harshness."

Exclusive patented features, such as the improved non-resonating Sound Conduit and the "floating" diaphragm, have made the AMPLION definitely and finally recognised as the *Loud Speaker Supreme*—the world's standard by which all others are judged.

Illustrated folder W.D.11—post free from the address below—describes AMPLION Loud Speakers priced at 25/- and upwards.

Obtainable from all Wireless Dealers of Repute.

Patentees and Manufacturers:

Telephone 1
SYDENHAM
2820/1/2

ALFRED GRAHAM & CO.,
(E. A. GRAHAM)
St. Andrew's Works, Crofton Park,
LONDON, S.E. 4.

Telegrams
"NAVALHADA,
CAIGREEN,
LONDON."

THE WORLD'S STANDARD WIRELESS LOUD-SPEAKER.

AMPLION

THREE POPULAR BOOKS

The CONSTRUCTION of CRYSTAL RECEIVERS

By ALAN L. M. DOUGLAS.

This book deals exclusively with crystal receivers for the reception of signals from the ordinary B.B.C. stations and also the high-powered station.

Price 1/6 net (post free 1/8).

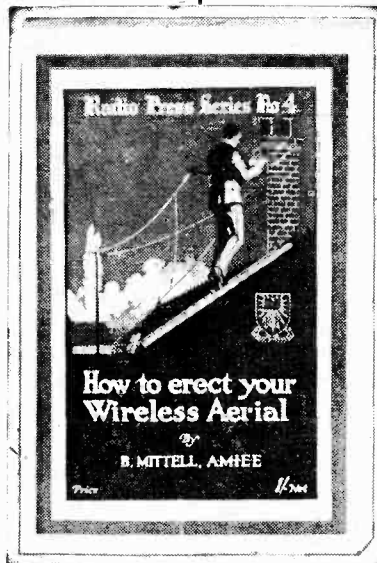

HOW TO ERECT YOUR WIRELESS AERIAL

By B. MITTELL, A.M.I.E.E.

To every newcomer and many "old hands" this book will make all the difference between poor and first-rate reception. Mr. Mittell is a professional radio engineer, and he has had many years' experience of aerial erecting and knows just those points where beginners go wrong. Incidentally, he took a prominent part in the erection of the huge aerials at Northolt and elsewhere. This is a useful volume which should be found on every wireless bookshelf.

Price 1/- net (post free 1/2).

HOW to MAKE your OWN BROADCAST RECEIVER

By JOHN SCOTT-TAGGART, F.Inst.P., A.M.I.E.E.

This book is by the Editor of *Wireless Weekly* and of *Modern Wireless*, and tens of thousands have made their first crystal set from this book, which is a sequel to "Wireless For All" and "Simplified Wireless."

This book contains much valuable data on aerials and how to erect them, and the purchaser can go straight home, make one of the three very simple and cheap sets, erect his aerial, and enjoy the programme from his local station or from the high-powered station.

Price 1/6 net (post free 1/8).

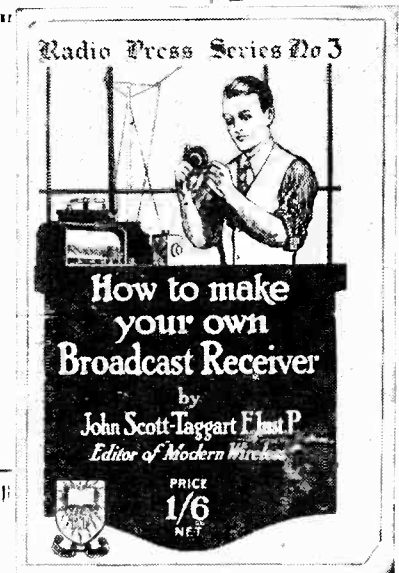

Published by RADIO PRESS, LTD.,
 Bush House,
 Strand, London, W.C. 2.

Barclays Ad. 1175

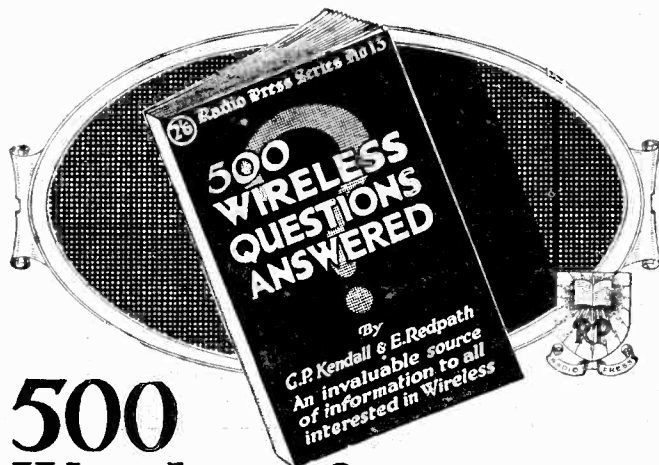

500 Wireless Questions answered.

By G. P. KENDALL, B.Sc.,
and E. REDPATH.

NO other Wireless Book sold at half-a-crown can approach this work in its general utility and scope. Keep it handy for ready reference, you'll need it many times in the course of a week. Its index enables information on any of the following subjects to be turned up in a moment:

Aerials, amplifiers, crystals, earths, frame aerials, grid leaks and grid condensers, interference, loud speakers, Morse, batteries, reaction, sounds and signals, telephone receivers, tuning coils, variable condensers, valves, wavelengths, etc., etc.

Some of the Questions fully Answered in this Book:

- Can two or more Receiving Sets be used on one Aerial?
- Will two Crystal Detectors in series give better signals?
- Is it possible to hear re-radiation on a Crystal Set?
- Is an indoor Aerial better than a Frame Aerial?
- How many turns of wire should a 4-ft. Frame Aerial contain for Broadcast use?
- How can an incorrect Grid Leak be diagnosed?
- How can noises from house lighting mains be reduced?
- What is the purpose of a Telephone Transformer?
- How is a coil pile wound?
- What is meant by negative Grid bias?
- How can the same H.T. Battery be used to give different voltages to the Detector and L.F. Valves in a Set?

Sold by all Booksellers.

Published by
RADIO PRESS, LTD.
Devereux Ct., Strand, W.C.2.

2/6

POST FREE, 2/8

RADIO PRESS SERIES No. 13.

G.A. 873

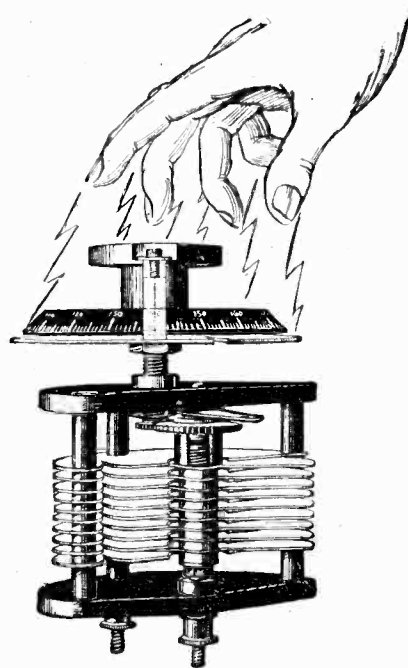

Another Refinement

—added to the "Fulstop" Condenser. The new registered stator vane of the "Fulstop" Condenser reduces the minimum capacity limit to an extremely low point because its shape eliminates all parallel lines as the moving plates rotate. This assists materially the possibilities of fine tuning.

This innovation is another proof that we leave no stone unturned to improve still further what is already the finest variable condenser in the world.

PRICES:

.001.....	13/6	.0003.....	10/3
.0005.....	11/3	.0002.....	9/6

Protected throughout the world.

Stocked by most Wireless Dealers, but
if you have any difficulty send direct to

J. H. NAYLOR, LTD., WIGAN.

VARIABLE CONDENSER

In replying to advertisers, use COUPON on last page

THE RADIO PRESS ENVELOPE SYSTEM

THE Radio Press Envelope System is generally acknowledged to be the greatest aid to the constructor yet evolved. Each envelope contains working diagrams, exact size blue prints of wiring and of the panel (suitable for drilling), a set of photographs printed on real art paper and in a manner impossible in a book or periodical and showing the set and wiring from every possible angle, a list of components and the full instructions for making each set and using it.

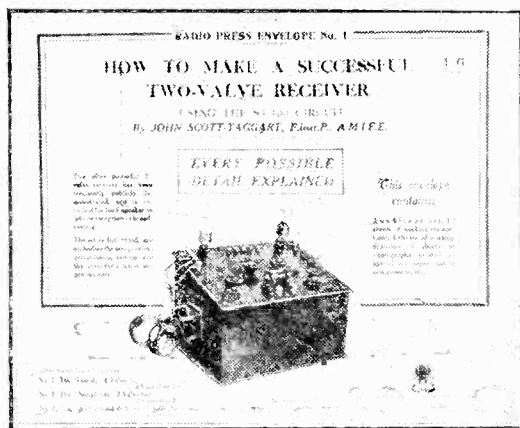

R.P. Envelope No. 1. Price 1s. 6d. (1s. 8d. post free). How to Make an Efficient 2-Valve Receiver using the ST. 100 Circuit. By John Scott-Taggart, F.Inst.P., A.M.I.E.E.

A huge number of this ST. 100 envelope has been sold, and practically all the tens of thousands of successful ST. 100 sets in the country have been made from this design, which works a loud-speaker with ease up to 35 miles.

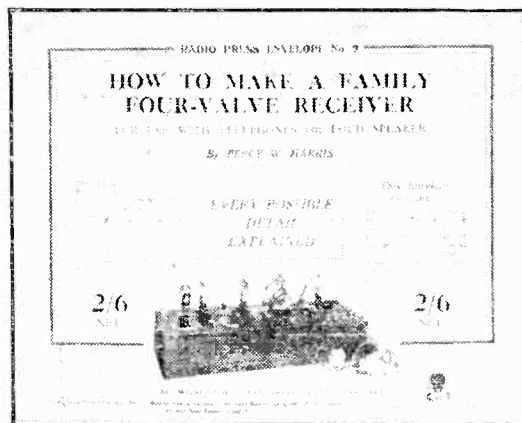

R.P. Envelope No. 2. Price 2s. 6d. (2s. 8d. post free). How to Make a Family 4-Valve Receiver. By Percy W. Harris.

This is the ideal easily-handled set for long range loud-speaker work. For those some distance from a station this set is ideal.

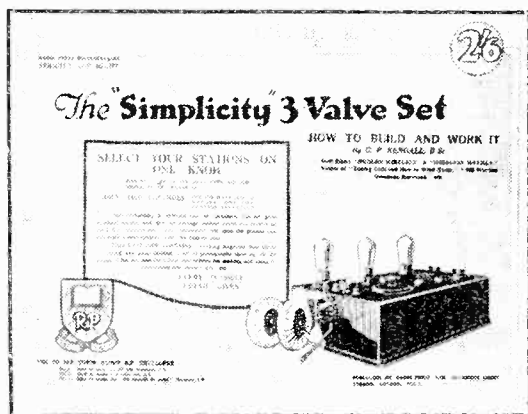

R.P. Envelope No. 3. Price 2s. 6d. (2s. 8d. post free). The "Simplicity" 3-Valve Set. By G. P. Kendall, B.Sc.

Notwithstanding extreme ease of operation this set gives excellent results and will receive all the B.B.C. stations and many Continental ones upon the phones and will work a loud-speaker from the nearest ones.



R.P. Envelope No. 4. Price 2s. 6d. (2s. 8d. post free). The "All-Concert de Luxe" Receiver. By Percy W. Harris.

A supremely efficient 3-Valve set with enclosed valves and all the latest technical improvements incorporated.

These envelopes are obtainable from all principal wireless dealers and booksellers or direct from the publishers:

RADIO PRESS, LTD., Bush House, Strand, London, W.C.2.

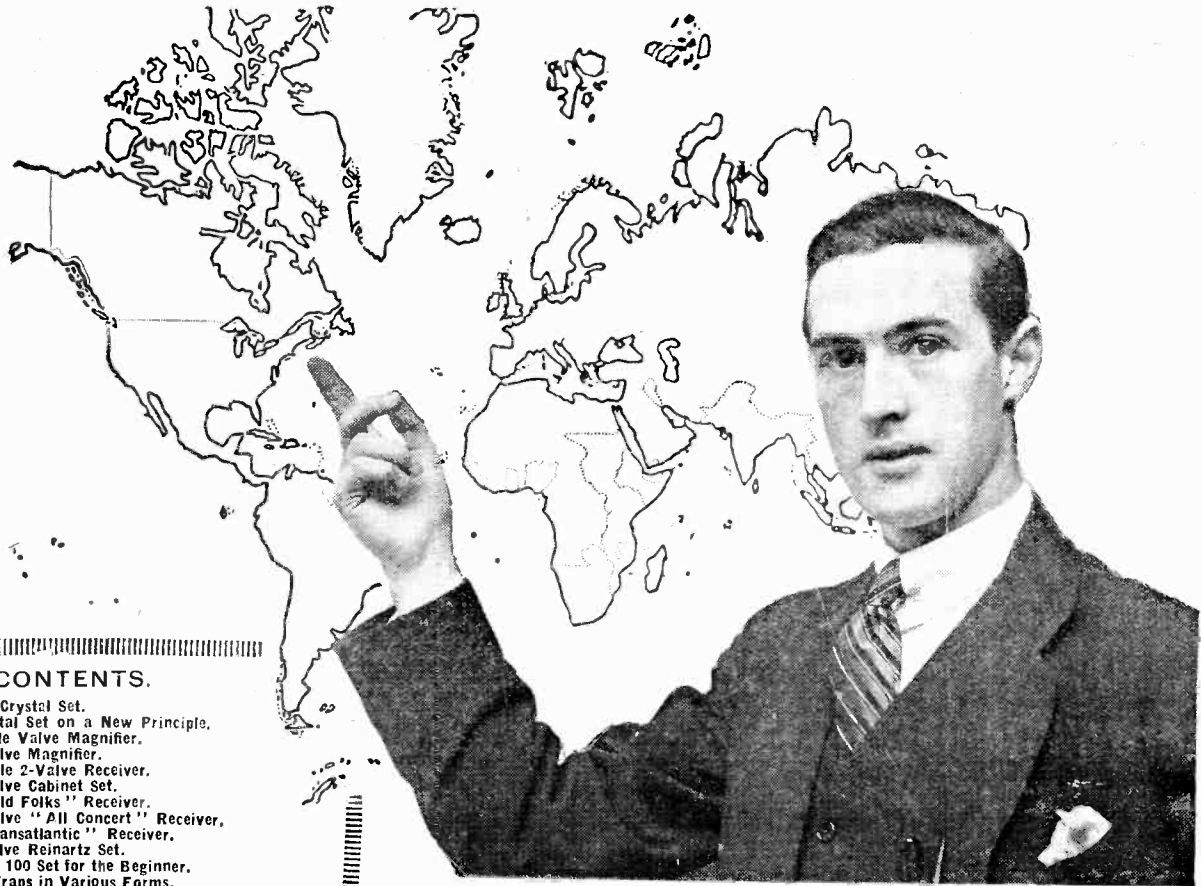

CONTENTS.

- 1 A 2/6 Crystal Set.
- 2 A Crystal Set on a New Principle.
- 3 A Single Valve Magnifier.
- 4 A 2-Valve Magnifier.
- 5 A Simple 2-Valve Receiver.
- 6 A 2-Valve Cabinet Set.
- 7 An "Old Folks" Receiver.
- 8 A 3-Valve "All Concert" Receiver.
- 9 A "Transatlantic" Receiver.
- 10 A 3-Valve Reinartz Set.
- 11 An S.T. 100 Set for the Beginner.
- 12 Wave Traps in Various Forms.

"I get these stations regularly"

So will you if you buy a copy of

TWELVE TESTED WIRELESS SETS

2/6 net.
Post Free
2/8

By **PERCY W. HARRIS**



And make one of the fine multi-valve sets such as the "Transatlantic." This is the season for receiving broadcasting from American and Continental stations, and there is no more fascinating or instructive pastime than searching for those elusive stations.

They will, however, not be elusive if you build a set produced by such an experienced designer as Mr. Harris.

Look at the varied contents and you will realise what a bargain such a cheap but reliable book is. Every set is not merely tested by the author but by hundreds, and sometimes thousands, of readers who have bought this book.

Buy it to-day from your wireless dealer or bookseller (2s. 6d. net) or send 2s. 8d. to the publishers:

RADIO PRESS, LTD.,
Bush House, Strand, London, W.C.2.

Barclays Ad. 1173

In replying to advertisers, use **COUPON** on last page



ENVELOPE No. 9

Contains all the necessary instructions with working drawings, blue prints, &c., for making the above

SINGLE VALVE SET

THIS set is designed by HERBERT K. SIMPSON, and dozens of letters have testified to its range and power.
Order "Radio Press" Envelope No. 9 to-day.

1/6 (Post free, 1/9.)

ENVELOPE No. 8

This envelope contains full and elaborate sheets of instructions, two full-size blue prints, three sheets of photographs on art paper and a sheet of working drawings, clearly showing how to make this—

ONE VALVE REFLEX RECEIVER

By Herbert K. Simpson.

An ideal one valve set for working a loud-speaker up to 10 miles from a broadcasting station. Strong 'phone signals are obtainable up to about 50 miles.

Order "Radio Press" Envelope No. 8 to-day.

1/6 (Post free, 1/9.)

Obtainable from booksellers and wireless dealers or direct from Radio Press, Ltd., the largest wireless publishers in the world, Bush House, Strand, London, W.C. 2.

**BUILD ONE OF
THESE FINE
"SIMPSON"
SINGLE VALVE
SETS**

**"RADIO PRESS"
ENVELOPES
Nos. 8 and 9
TELL YOU
HOW**



440,000!

DON'T EXPERIMENT with so-called infallible media for SELLING your Wireless Sets, Components or Accessories. Experimenting with Wireless Sets may be—and no doubt is—a lucrative and instructive hobby, but experimenting with your business and its capital is another thing altogether. It is invariably Suicidal. Start right at the commencement of your campaign by using only "MODERN WIRELESS," "WIRELESS WEEKLY" and the "WIRELESS CONSTRUCTOR," the predominant, threes in wireless, and, incidentally, the only journals that matter in creating a public demand for your manufactures. When you have booked space in them your appropriation is complete and beyond equal.

In substantiation of this statement your advertisement will be read by no fewer than 440,000 wireless enthusiasts—those that are really keen and are continually buying for new experiments and home-constructed sets. This figure represents the certified circulation of these papers, one of which alone has a circulation greater than that of all Non-Radio Press wireless papers added together. The elite and professional men, besides the amateur and experimenter, are readers and all may, therefore, be safely classed as potential customers. In fact there is no waste circulation whatever.

Do not tolerate disappointing results any longer—they can be remedied, and speedily too.

Phone: City 9911 (Extn. 9), or write for advertisement rates of "MODERN WIRELESS," "WIRELESS WEEKLY" AND "WIRELESS CONSTRUCTOR" to the Advertisement Manager.

BARCLAYS ADVERTISING, Ltd.

Advertising Agents, Consultants & Contractors,

BUSH HOUSE, STRAND, LONDON, W.C.2.

Telephone. City 9911 (Extn. 9).

*The Media in
Wireless Journalism*

which constitute a complete and efficient Advertising Campaign for Selling Sets Components or Accessories.

Why I read "Wireless Weekly"

1. BECAUSE, chiefly, I feel safe. I know that behind this paper is the RADIO PRESS, the largest Wireless Publishing concern in the World, and this is **their** weekly.
2. BECAUSE the Editor, is John Scott-Taggart, F.Inst.P., A.M.I.E.E., and the Assistant Editor is Percy W. Harris, and because this is the only paper which contains articles by such other well-known writers as Cowper, Hallows, Kendall, Rattee, Redpath, etc., etc.
3. BECAUSE it is beautifully printed on the finest quality paper, and all the photographs come out clearly and not as smudges, as is so often the case.
4. BECAUSE of the regular "Valve Notes" which appear weekly and are written by the Editor. Nothing like these appears anywhere else. WIRELESS WEEKLY appeals to me because I am a valve user, and the paper caters very largely for the valve man.
5. BECAUSE I thoroughly enjoy "Jottings By the Way," a very witty weekly feature (now illustrated), by the way.
6. BECAUSE new circuits and designs appear regularly and many of them never appear elsewhere. I know that if I miss my WIRELESS WEEKLY I shall miss something new.
7. BECAUSE I am pleased to reply "WIRELESS WEEKLY" when my friends ask me what I read. I know that they know that WIRELESS WEEKLY is a paper in a class by itself. Its price is the highest of the weeklies, and though not a snob, I don't mind my friends knowing that I want the best—and get it.
8. BECAUSE it's a "live" paper. It does things. It's the most virile of the RADIO PRESS periodicals. It criticises fearlessly on wireless topics of the day. Its test reports on wireless apparatus are equally fearless. If something new comes along, whether it is oscillating crystals, a new circuit, a new move by the Post Office, every keen wireless man wants to know "what WIRELESS WEEKLY has to say about it"—and they are never disappointed.

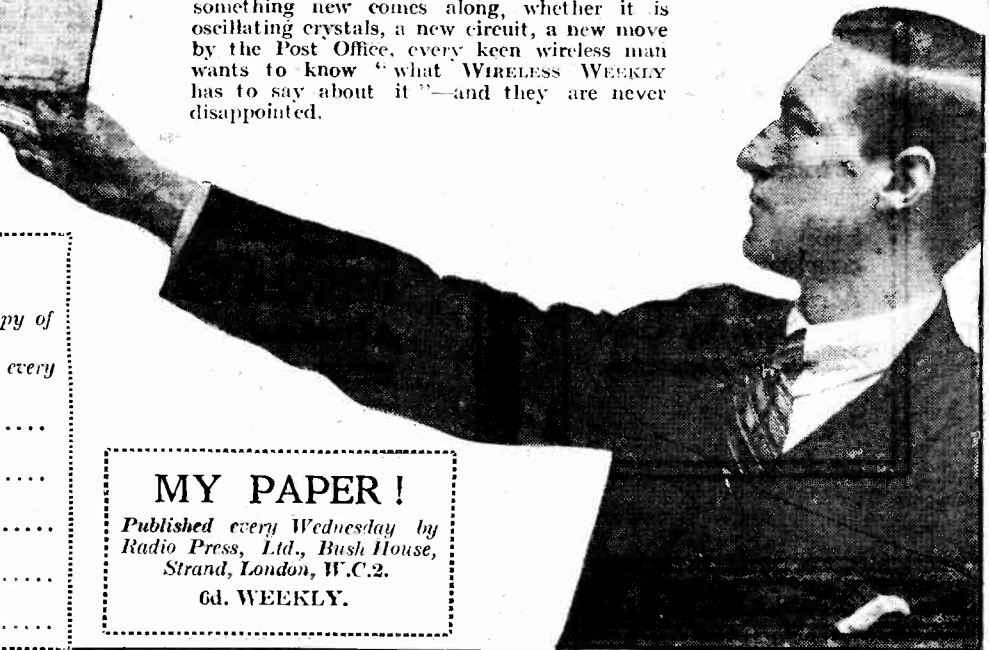

Cut Here.

To Newsagent.

Please { *deliver* / *reserve* } me a copy of

"WIRELESS WEEKLY" every week.

Name.....

Address.....

.....

.....

.....

MY PAPER!

Published every Wednesday by
Radio Press, Ltd., Bush House,
Strand, London, W.C.2.

6d. WEEKLY.

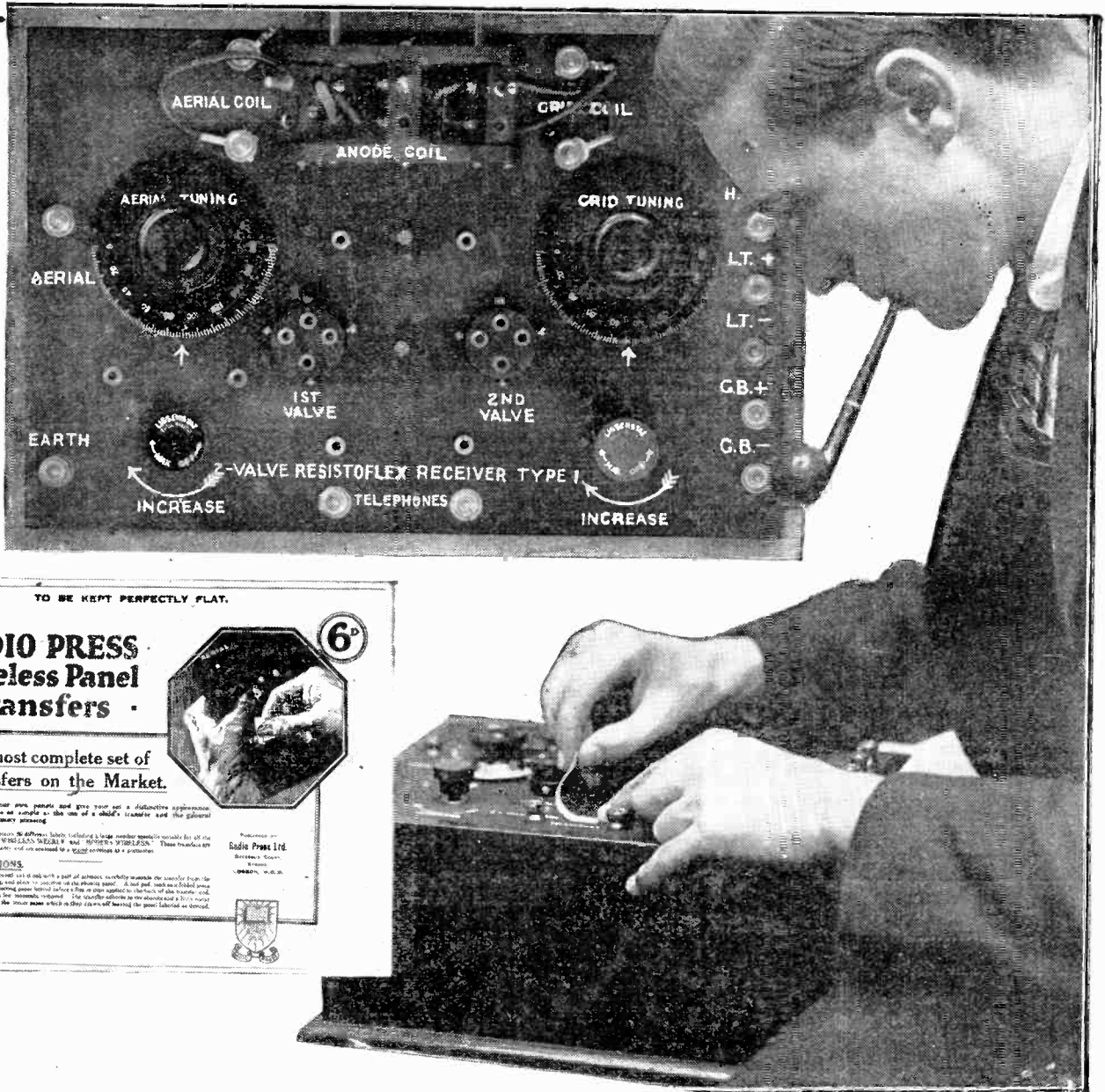

TO BE KEPT PERFECTLY FLAT.

RADIO PRESS
Wireless Panel
Transfers

6^d

The most complete set of
Transfers on the Market.

“Employs” your own panels and give you set a distinctive appearance.
The process is so simple as the use of a child’s transfers and the general
effect is extremely pleasing.

This transfer covers 96 different labels including a large number specially made for all
the sets described in “WIRELESS WIZARD” and “WIRELESS WISDOM”. These transfers are
of Radio Press quality and are issued in a 6222 transfer set in a postpaid envelope.

INSTRUCTIONS
Before the first transfer set is used with a set of apparatus, carefully examine the transfer from the
set you are using, and stick to one set of the same kind. A set of transfers is sold in a
small case in which the transfers are kept in a tin or other suitable material, and the
instructions for use are printed on the back of the case. The transfers should be removed
in order to receive the most complete set of transfers in their cases will bring the most complete set.

Patented by
Radio Press Ltd.
Buckingham Court,
London, W.C.2.

Give your set "that professional look!"

By using "Radio Press Wireless Panel Transfers" (6d. per large packet of 80 labels), you can give to your set that finished appearance which makes all the difference. Not only are these transfers the cheapest and best but they are officially issued by the Radio Press for their sets. Buy a packet or two from your wireless dealer. They are also obtainable through every bookseller, *but get the title right* if you want Radio Press quality.

8d. post free from RADIO PRESS, Ltd., Bush House, Strand, London, W.C.2.

Barclays Adv. 102

In replying to advertisers, use COUPON on last page

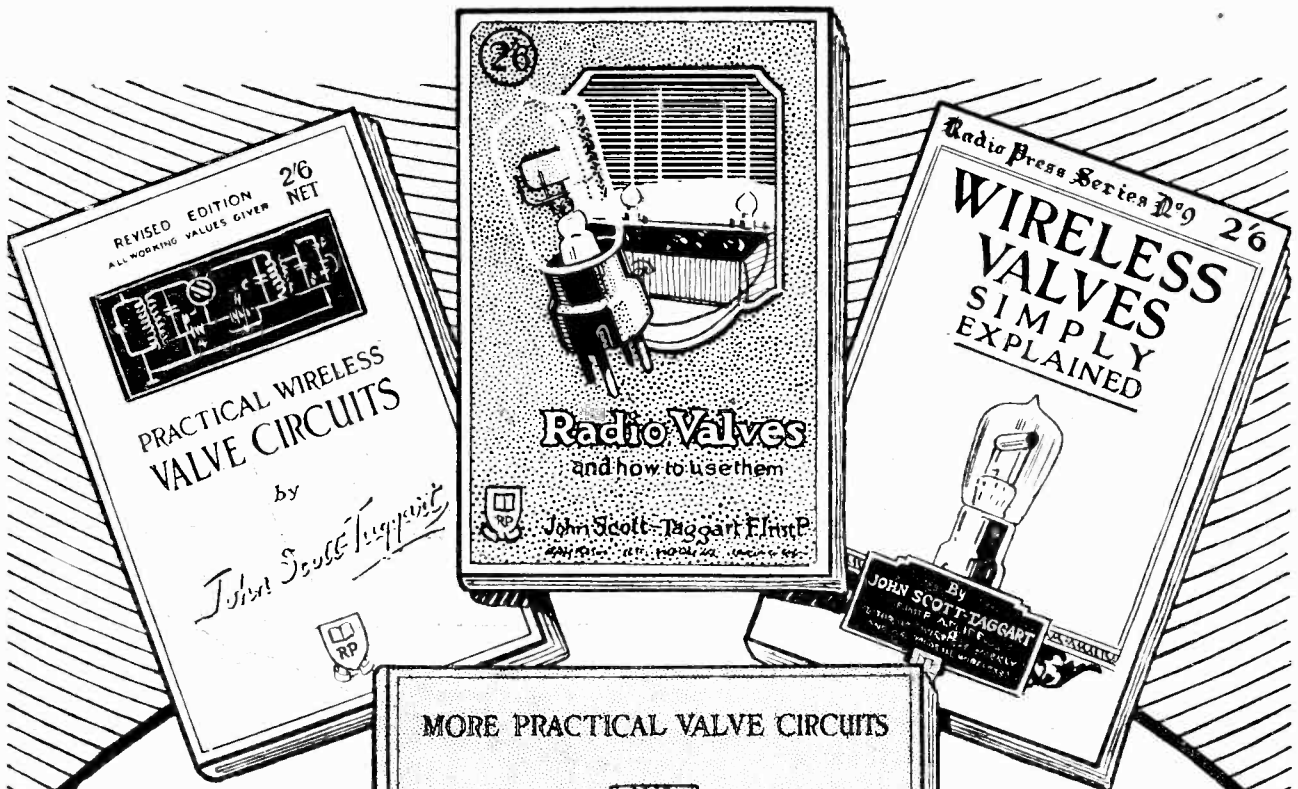

YOU NEED THESE BOOKS

Practical Wireless Valve Circuits

This is the first book of ST circuits and is called **Practical Wireless Valve Circuits**, by John Scott-Taggart, F.Inst.P., A.M.I.E.E. Price 2/6 (post free 2/8). Circuits ST 1 to ST 67 are published in this book, which is selling as well to-day as when it was published. No experimenter worthy of the name can afford to be without the two ST Circuit Books. They are friends which will never lead you astray. Each circuit in both books is fully described and criticised.

All component values are given in the new editions of THESE TWO CIRCUIT BOOKS.

MORE PRACTICAL VALVE CIRCUITS



JOHN SCOTT-TAGGART, F.Inst.P.

"S.T." Circuits

These are too well known to need any introduction. This is the latest book of them:—

More Practical Valve Circuits

By JOHN SCOTT-TAGGART, F.Inst.P., A.M.I.E.E.
Price 3/6 (post free, 3/8).

Full of dozens of original circuits which you will find nowhere else, as they are copyright. Circuits ST 68 to ST 151 appear in this extremely useful volume, which has had an enormous sale amongst experimenters.

Radio Valves and How to Use Them

Mr. Scott-Taggart has stated that he regards this as his best book on the Valve from the point of view of the beginner. **Radio Valves and How to Use Them**, by John Scott-Taggart, F.Inst.P., A.M.I.E.E. Price 2/6 (post free 2/8). This book is by far the largest published by Radio Press, Ltd., at 2/6, and is full of very valuable information. The reader is presumed to know only what is contained in our Books, "Wireless For All" and "Simplified Wireless."

YOU NEED THESE BOOKS

Wireless Valves

Simply Explained

By JOHN SCOTT-TAGGART, F.Inst.P.

The most popular moderately priced Book on the theory of Wireless yet written. It contains the results of many years' patient research and experiments—but told in a non-technical language which the amateur can easily understand.

How reaction is caused—how to stop self-oscillation—how to select suitable circuits for various purposes—how to receive C.W.—the answers to all these and many other questions are clearly given.

If you want to know how your set works this is the Book you need.

2/6 or 2/8 post free.

All Radio Press Books are obtainable from principal wireless dealers and through any bookseller, newsagent, or from Radio Press Ltd.

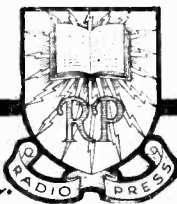

Radio Press, Ltd.

BUSH HOUSE, STRAND, LONDON, W.C.2



Every step fully explained—

EVEN if a man has never built a Set before—if he has never had the opportunity of examining one closely—if he knows absolutely nothing about Wireless—if he has no friends to advise him—he could still select a suitable design from among those described in "*Wireless Sets for Home Constructors*," and get splendid results from the very beginning.

The complete beginner—if he lived near a Broadcasting station—would probably build one of the Crystal Sets. Even if he wished to start with a Valve Receiver right away, without going through a probationary period

on a Crystal Set, he would find the 2-Valve Broadcast Receiver a wonderfully simple and efficient instrument, costing but little for material. The more advanced experimenter, on the other hand, will appreciate the many exclusive and original features which are incorporated in the 4-Valve Universal Receiver—its sensitiveness and its power.

In any case, we would emphasise that the reader will find every step fully described and explained in the clearest and most interesting manner.

SHOWS HOW TO BUILD:

- Simple Crystal Receivers.
 - An inductively-coupled Crystal Set.
 - A two-valve Low Frequency Amplifier.
 - A two-valve Broadcast Receiver.
 - A three-valve Regenerative Receiver.
 - A single-valve Reflex Receiver.
 - A three-valve Broadcast Receiver.
 - A four-valve Universal Receiver.
- Together with information as to the testing and operation of Receiving Sets

Published by Radio Press Ltd., Dush House, Strand, W.C.2.
Post free 2/8.

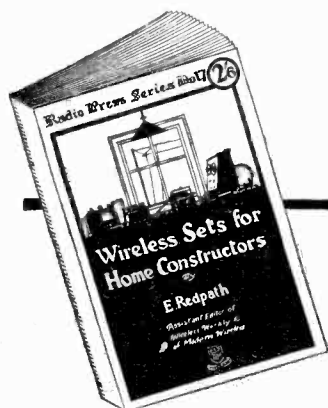

Wireless Sets for Home Constructors

By E. Redpath.

2/6

Radio Press Series No 17.

In replying to advertisers, use COUPON on last page

Gilbert Ad. 1175
1019

Index to Advertisers

	PAGE		PAGE		PAGE
Agar (W. H.)	949	Fellows Magneto Co., Ltd.	929	Peto-Scott Co.	994
American Hard Rubber Co., Ltd. .. .	996	Finchett (C. A.)	1020	Pickett Bros.	1020
Anderson's Sales Agency	1007	Fletcher (F. & J.)	949	Portable Utilities Co., Ltd.	1005
Arrigoni (C. & J.)	1003	Forno Co.	958	Power Equipment Co.	958
Athol Engineering Co.	1001	Fuller's United Elec. Works, Ltd. .. .	1000	Pressland Elec. Supplies	993
Autoveyors, Ltd.	987	Gambrell Bros., Ltd.	1001	Radiax, Ltd.	1006
B.D. & Co.	1006	General Electric Co., Ltd.	918	Radio Communication Co., Ltd. 890,	978
Beard & Fitch	950	General Radio Co.	966	Radio Improvements, Ltd.	949
Bowyer-Lowe Co.	938	Gent & Co.	993	Radio Instruments, Ltd.	Cover iv.
Brandes, Ltd.	914	Goswell Engineering Co.	965	Rad'o Panel Co.	972
British Battery Co., Ltd. (The) .. .	992	Graham (A.) & Co.	1009	Radio Stocks	986
British Thomson-Houston Co. .. .	934	Gran-Goldman Service	929	Radions, Ltd.	972
Brown Brothers, Ltd.	925	Helixo, Ltd.	942	Raymond (K.)	971
Brown (S. G.), Ltd.	998	Hobday Brothers	974	Robinson (Lionel) & Co.	957
Burndept, Ltd.	Cover ii.	H. T. C. Electrical Co.	889	Rose Bros. Elec. Co.	1001
Burne-Jones & Co., Ltd.	942	Hughes (F. A.) & Co.	990	Rosen (Ed.) & Co.	964
Buss (T. O.)	1003	Hunt (A. H.), Ltd.	1091, 1003	Rothermel (R. A.), Ltd.	961
Carpax Co.	1007	Igranic Electric Co., Ltd.	962	"S. A. Cutters"	1003
C.A.V. Small Tools	987	Jackson Bros.	925	Shipton (E.) & Co.	985
Chase Electrical Co.	1006	Lighting Supplies Co.	1006	Silvertown Co.	997
Chloride Elec. Storage Co., Ltd. .. .	1002	Lissen Co.	£20, 921	Simpson & Blythe	988
Clarke (H.) & Co. (Manchester), Ltd.	908	Louden Valves	987	Smith & Ellis	949
Climax Patents	990	McMichael (L.), Ltd.	1000	Spot Components Co.	1001
Collinson's Precision Screw Co., Ltd.	961	Marconiphone Co.	926	Sterling Telephone Co., Ltd.	917
Cosson Valve Co.	976, 977	Marconi-Osram Valve Co.	918	Stevens (A. J.) & Co. (1914), Ltd.	982
Cunningham & Morrison	984	Marshall (H. Lloyd)	972	Stockall, Marples & Co.	953
Curtis (Peter), Ltd.	930, 937, 988	Melhuish (Rd.) & Co.	1007	Summit Mfg. Co.	1003
Diamond Wireless, Ltd.	953	Molback (M.)	929, 1006	Telephone Mfg. Co.	949
Drummond Bros.	992	Mullard Radio Valve Co., Ltd. .. .	946	"U. S." Radio Co.	922
Dubilier Condenser Co. (1921), Ltd.	941, 981	Naylor (J. H.)	1011	Vandervell (C. A.)	957
Economic Electric, Ltd.	974	Neutron, Ltd.	945	Ward & Goldstone, Ltd.	999
Ensign Radio Co.	1007	New London Electron Works	925	Wates Bros.	992
Falk, Stadelmann & Co.	1007	Nichol (J. O.) & Co.	1007	Watmel Wireless Co.	988
Fallon Condenser Co.	995	Oldham Accumulators	1004	Wilkins & Wright, Ltd.	961, 993
		Ormond Engineering Co.	1008		

100% EFFICIENCY H.T. BATTERY. THE CONSTRUCTOR'S IDEAL.



Amazing value, positively unequalled. See "Apparatus tested," April issue. Giant Unit Dry Cells, 1½ volts, 1½ in. diam. 300% more capacity. Compare tiny standard cells on photo. Terminalled and insulated. Cells, 4/- doz., carriage extra. 60 volt type in polished Oak Case, as reported, 19/6 carriage 1/9. All Cells replaceable. Lists free. Sample Cell 6d. From actual maker only, saving 50% middlemen's profits. Money back guarantee.
Sole Maker: **FINCHETT (C.A.), OLD ARMOURY, OSWESTRY.**

CABINETS YOU WANT



PICKETT'S Cabinets—they are good value, from 1/6 each, highly polished. Cabinet Works, Albion Rd., Bexley Heath, S.E.1. Write for Lists M.W.

COUPON

Questions and Answers

In future this coupon must be accompanied with
2s. 6d. P.O.

"MODERN WIRELESS" January, 1925.



Hearty Greetings
to all our clients in
the Wireless Industry
and
Best Wishes for
Continued Prosperity
throughout
1925

BARCLAYS ADVERTISING LTD.
BUSH HOUSE · STRAND · LONDON · W.C.2



Two Popular Envelopes and A Book

BY

PERCY W. HARRIS

Editor of "The Wireless Constructor."

Mr. Harris' reputation as a constructional writer and designer is second to none.

With an almost uncanny knowledge of the needs of the "home constructor," he is not only able to design sets which rank as the best of their kind, but he is able to describe them with a skill which enables even the beginner to follow his designs and obtain equally good results. Tens of thousands of sets have been made according to his designs, and every one has enhanced the reputation of the author and also that of Radio Press Ltd., who have the exclusive services of Mr. Harris.

Mr. Harris has two envelopes to his credit, Nos. 2 and 4 of the Radio Press Envelope series, each containing pages of photographs on art paper, sheets of instructions, wiring and panel blue prints, lists of components, and, in fact, all the features which have made Radio Press Envelopes the last word in guides to the constructor. He has also written a standard constructional work, "Twelve Tested Wireless Sets," which has had an enormous sale and which will strongly appeal to readers of "Modern Wireless" as all kinds of sets, from a crystal to a "Transatlantic," are fully described.

Read this letter from the South-West of Africa.

SIR,—I suppose you will be surprised at hearing from someone in the outskirts of the Empire, but I am only writing you a few words of appreciation of the Family four-valve set described in Radio Press Envelope No. 2. This compact little set is by far the best operating set I have yet handled. Having had nearly 15 years' wireless experimenting, I have naturally handled many sets.

As to results obtained, these exceeded anything like expectations. Cape Town (750 miles) comes in at good strength on H.F. and detector. With note magnifier added, signals are too loud for 'phones. The power of Cape Town is the same as 2LO, so these results are far better than could be hoped for. JB (Johannesburg), with 1/2 kw. in the aerial, comes in quite loud on two valves, his distance being 740 miles. Shipping comes in with a roar. 5XX comes in with fair 'phone strength on three valves. Three a.m. one morning I managed to pick up KDKA on three valves at good 'phone strength. All high-power Morse stations come in well, and I can get them any time of day or night on two valves.

Hoping you will find this interesting, and congratulating you most heartily on your design of a thoroughly reliable and efficient set.

Yours truly, PERCY F. SYMONS.

Windhoek, S.W. Africa.

And this one :

SIR,—About three weeks ago I purchased the envelope containing particulars regarding the "All Concert Receiver," and wish to give you my results.

Without any wavetrap I am able to tune in 2BD at excellent loud-speaker strength, and with very slight interference from 5NO.

OTHER RESULTS: Radio-Paris, loud-speaker. 5XX, good; 5NO, excellent; 2BD, excellent; 5SC, good; these are all the B.B.C. stations which I have bothered with so far. Le Petit Parisien, loud in 'phones. Vox Haus? (woman announcer), fair loud-speaker. Hamburg, good loud-speaker. Breslau, fair loud-speaker.

I have had many more foreign stations than these, but have not heard their call signs.

HENRY R. MYERS.

Durham.

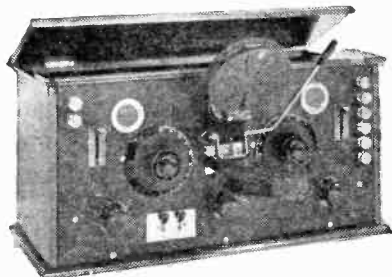

Envelope No. 4.

Twelve Tested Wireless Sets .. 2/6d. 2/8d. post free.

By Percy W. Harris.

Radio Press Envelope No. 2 .. 2/6d. 2/9d. ,, ,,

By Percy W. Harris.

(4-Valve Family Receiver)

Radio Press Envelope No. 4 .. 2/6d. 2/9d. ,, ,,

By Percy W. Harris.

(3-Valve All Concert de Luxe.)

All obtainable from wireless dealers and booksellers, or direct from the publishers, Radio Press Ltd., Bush House, Strand, London, W.C.2

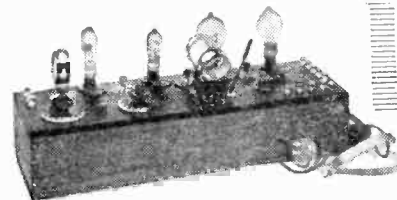

Envelope No. 2.

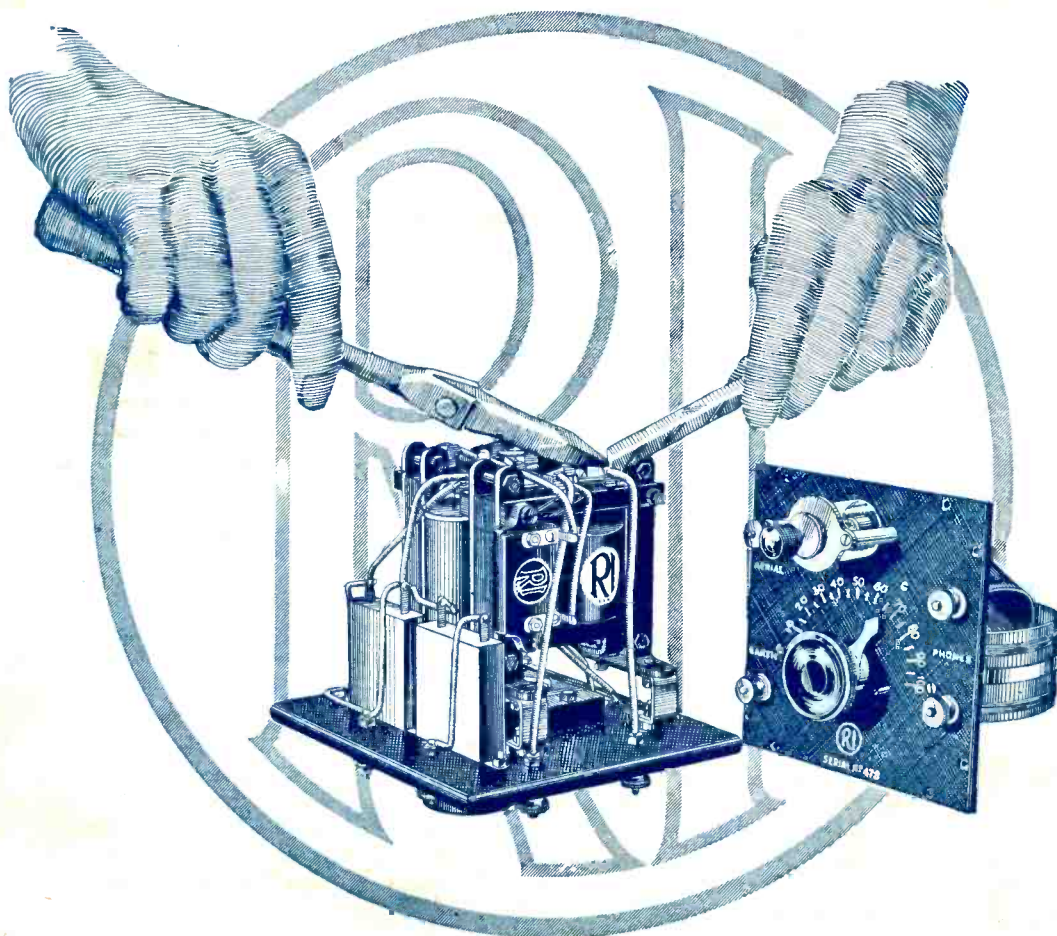

THE WORK OF A SPECIALIST—

You feel the pride of being a real specialist in radio when you complete the last connection of your set built with R.I. components. You can show a neat, compact and skilfully built set that WORKS. A set whose construction throughout holds the secret of 25 years of radio science.

IT PAYS TO BUILD WITH GOOD MATERIALS.

See that you emphasise the R.I. with all your purchases. Two R.I. Transformers coupled with an R.I. Detector will give you the finest amplifying unit possible.

The New R.I. Transformer..... 25/-

Write for new R.I. catalogue.



Radio Instruments Ltd.
12 Hyde Street, Oxford Street

Telephone: REGENT 6214 (3 lines) W.C.1. Telegrams: Inradio London.